



Mapesonic™ 2

All-in-One Membrane for Crack Isolation, Sound Reduction, Waterproofing and Vapor Management



DESCRIPTION

Mapesonic 2 is a patented, next-generation, flexible, 76-mil thin, lightweight, load-bearing, fabric-reinforced, “peel-and-stick” membrane for sound reduction, crack isolation, waterproofing and vapor management. Application of *Mapesonic 2* can be immediately followed by installation of finished flooring.

Mapesonic 2 reduces transmission of impact sound (such as footsteps and dropped objects) and airborne sound (such as voice and TV) through floors when installed under ceramic tile, stone, vinyl and wood floorings. It also helps to prevent existing or future in-plane floor cracks (with movement up to 3/8" or 10 mm wide) from transmitting through grout, ceramic tile and natural-stone assemblies.

FEATURES AND BENEFITS

- Patented design: Sound-reduction performance with less weight and thickness
- ASTM C627 Service Rating (Robinson): Extra Heavy
- Dual protection: Provides sound reduction and crack isolation
- Semi-rigid sheet: Easy to position on floor and cut to size
- Split-back release film: Installs faster than membranes with one-piece liners
- White surface: Easy to view under lower-light conditions
- Thin-film adhesive backing: Bonds to a variety of substrates
- Time-saving: Prime, peel, stick and then install tile, vinyl or wood immediately
- No odor: Great for confined spaces
- Contains post-industrial, recycled material

- Certified by SCS Indoor Advantage Gold

INDUSTRY STANDARDS AND APPROVALS

- ASTM C627 (Robinson): See the “Product Performance Properties” chart below.
- ASTM E492-04 (Impact Sound), E90-04 (Airborne Sound) and E2179 (Impact Sound): See the “Product Performance Properties” chart below.
- ANSI A118.13 (Bonded Sound Reduction Membranes for Thin-Set Ceramic Tile Installation): *Mapesonic 2* exceeds the standards for bonded sound-reduction membranes. See the “Product Performance Properties” chart below.
- ANSI A118.12 (Crack Isolation for Tile & Stone): *Mapesonic 2* exceeds the high-performance standards for crack isolation. See the “Product Performance Properties” chart below.
- ANSI A118.10 (Specifications for load-bearing, bonded, waterproof membranes for thin-set ceramic tile and dimension stone installations), when used with *Mapetape™ BB* butyl-based waterproofing sealing tape: See the “Product Performance Properties” chart below.
- ASTM E-96 (Standard test method for water vapor transmission of materials) when used with *Mapetape BB*: See the “Product Performance Properties” chart below.

WHERE TO USE

- Floor applications that are residential (homes, apartments and condominiums) and commercial/industrial (airports, malls, office buildings, restaurants and galleries), both interior and exterior (with proper drainage)
- For under ceramic tile, natural stone, vinyl and wood flooring



Mapesonic™ 2

- For installations requiring TCNA environmental exposure classifications Res1, Res2, Res6, Com1, Com2 or Com6

Sound reduction (for tile, stone, vinyl and wood floorings)

- For interior residential, commercial and industrial floors
- Ideal for multi-family or multi-story buildings where noise transmission is a common problem
- Reduces transmission of impact sound and airborne sound through tile, stone, vinyl and wood floorings

Crack isolation (for grout, ceramic tile and natural stone)

- For interior residential, commercial and industrial floors
- For properly sloped residential exterior environments, such as balconies
- Helps to prevent existing or future in-plane substrate cracks (with movement up to 3/8" or 10 mm wide) from transmitting through grout, ceramic tile and natural stone

LIMITATIONS

(for *Mapesonic 2* utilizing *MAPEI SM Primer™*, *MAPEI SM Primer Fast* or *MAPEI HM Primer™*)

- Do not use over cracks or control joints subject to out-of-plane movement, or to in-plane movement greater than 3/8" (10 mm).
- Do not cover expansion joints. Refer to the most current TCNA Handbook, Detail EJ171, or TTMAC Tile Installation Manual, Detail 301MJ.
- Do not use over substrates containing asbestos, plank wood flooring, presswood, particleboard, chipboard, pressure- or oil-treated plywood, Luan plywood, Masonite, self-stick tile, laminate, metal or fiberglass surfaces, or similar dimensionally unstable materials.
- Do not use where excessive substrate moisture and/or negative hydrostatic pressure exists.
 - The maximum amount of acceptable moisture in a concrete substrate primed with *MAPEI SM Primer* is 5 lbs. per 1,000 sq. ft. (2.27 kg per 92.9 m²) per 24 hours as determined by an ASTM 1869 calcium chloride test kit.
 - The maximum amount of acceptable moisture in a concrete substrate primed with *MAPEI SM Primer Fast* is 8 lbs. per 1,000 sq. ft. (3.63 kg per 92.9 m²) per 24 hours as determined by an ASTM 1869 calcium chloride test kit.
 - The maximum amount of acceptable moisture in a concrete substrate primed with *MAPEI HM Primer* is 15 lbs. per 1,000 sq. ft. (6.80 kg per 92.9 m²) per 24 hours using an ASTM 1869 calcium chloride test kit. Do not install when the relative humidity of concrete slabs exceeds 95% (ASTM F2170).
 - When moisture vapor emissions are in excess of 15 lbs. per 1,000 sq. ft (6.80 kg per 92.9 m²) per

24 hours, contact MAPEI's Technical Services Department for recommendations.

- Do not use on vertical surfaces; under glass tile installations; or as a roof deck membrane or wear surface.
- Do not use on shower floors, in submerged applications or on floors subject to standing water.
- Exterior applications must be appropriately sloped to prevent standing water.
- Do not use self-leveling products over *Mapesonic 2*.
- Do not use premixed products to set tile over *Mapesonic 2*.
- Do not install moisture-sensitive tile or stone with water-based setting materials.
- Do not use with radiant floor-heating systems.
- If using *Mapesonic 2* for vapor management, do not use *MAPEI SM Primer* or *MAPEI SM Primer Fast*. *MAPEI HM Primer* must be used, with the maximum amount of acceptable moisture in a concrete substrate of 15 lbs. per 1,000 sq. ft. (2.27 kg per 92.9 m²) per 24 hours using an ASTM 1869 calcium chloride test kit. Do not install when the relative humidity of concrete slabs exceeds 95% (ASTM F2170).

Note: On occasion, dimensionally weak natural-stone tile that normally would not be categorized as moisture-sensitive (such as travertine, limestone, marble and agglomerates) can exhibit doming, cupping or curling when wet-set or medium-bed mortar methods of installation are used over impervious sheet membranes such as *Mapesonic 2*. Do not use a thin-set or large-and-heavy-tile mortar to compensate for irregularities in the substrate or to increase the elevation of the finished installation. A self-leveling underlayment or cured mortar bed should be applied to compensate for these conditions before installation of *Mapesonic 2*. When installing natural stone, always do a mockup area of the proposed installation and allow materials to reach a full cure to ensure the desired effect. For more information regarding these methods or materials, contact MAPEI's Technical Services Department before installation or design.

SUITABLE SUBSTRATES

- Fully cured concrete (at least 28 days old)
- Cement mortar beds and leveling coats
- Cement backer units (CBUs) – see manufacturer's installation guidelines
- Cement terrazzo floors, and well-bonded ceramic tile and natural stone
- Well-bonded vinyl composition tile (VCT)
- APA Group 1 and CANPLY 0121 exterior-grade plywood (interior, residential and light commercial in dry conditions only)
- Plywood or oriented strand board (OSB). Tile must be installed per installation standards published in the

most current TCNA Handbook, ANSI 108 specification. If the OSB is weather-beaten or delaminated, it must be properly overlaid with a cement backer unit or an additional layer of subfloor.

- Steel subfloor, when primed with *MAPEI HM Primer*
- MAPEI's *Planiseal® PMB*
- MAPEI's *Mapelastic® AquaDefense* and *Mapelastic Turbo*

Consult MAPEI's Technical Services Department for installation recommendations regarding substrates and conditions not listed.

Tile Council of North America (TCNA) Statement on Deflection Criteria

Floor systems, including the framing system and subfloor panels, over which tile will be installed should be in conformance with the IRC [International Residential Code] for residential applications, the IBC [International Building Code] for commercial applications, or applicable building codes.

Note: The owner should communicate in writing to the project design professional and general contractor the "intended use" of the tile installation, in order to enable the project design professional and general contractor to make necessary allowances for the expected live load, concentrated loads, impact loads, and dead loads including the weight of the tile and setting bed. The tile installer shall not be responsible for any floor framing or subfloor installation not compliant with applicable building codes, unless the tile installer or tile contractor designs and installs the floor framing or subfloor.

SURFACE PREPARATION

- All suitable substrates must be smooth, structurally sound and free of any substance that could prevent adhesion.
- Unprimed gypsum-based patching or leveling compounds may leave a dusty residue on the surface. Clean the dusty substrate before priming with *MAPEI SM Primer*, *MAPEI SM Primer Fast* or *MAPEI HM Primer*.
- Do not use chemical means (acid etching or stripping) to prepare approved substrates. Use mechanical methods only.
- To remove any bond-inhibiting materials, concrete substrates should be mechanically cleaned and prepared by diamond-cup grinding or other engineer-approved methods to obtain the International Concrete Repair Institute (ICRI) concrete surface profile (CSP) #2. If concrete requires more mechanical preparation, the increased profile of the surface should be made smooth by applying *Mapecem® Quickpatch*. For large areas, consider using one of MAPEI's self-leveling underlayments. See respective Technical Data Sheets (TDSs) for details.
- Install *Mapesonic 2* only in conjunction with undiluted *MAPEI SM Primer*, *MAPEI SM Primer Fast* or *MAPEI HM Primer*. Allow the primer to dry tacky before *Mapesonic 2* is installed. Confirm that the primer is

sufficiently tacky before *Mapesonic 2* is installed; more than one coat of primer may be required to achieve sufficient tack.

See the "Surface Preparation Requirements" reference guide in the Tile & Stone Installation Systems section of MAPEI's Website.

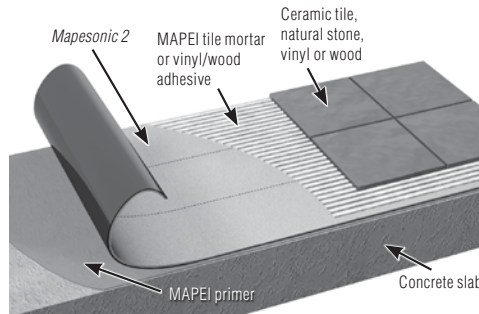

PRODUCT APPLICATION

Read all installation instructions thoroughly before installation.

Apply *Mapesonic 2* when substrate and ambient temperatures are between 40°F and 95°F (4°C and 35°C).

Isolation of existing cracks before tile installation

1. *Mapesonic 2* may be applied directly to the substrate area that has existing in-plane cracks (with movement up to 3/8" [10 mm] wide).
2. Cut *Mapesonic 2* to size so that the length and width of the membrane will cover the entire length and width of the crack, plus 3 times the width of the largest tile being used.
3. Center the cut membrane over the crack's width and length. Mark on the floor where the membrane is to start.



4. Set aside precut sections (or entire rolls) of *Mapesonic 2*. Continue with installation instructions at Step 2 in the "Full-floor" instructions below.

Full-floor sound reduction (or crack isolation)

1. To effectively achieve sound reduction and to isolate and protect an entire tile installation from existing or future substrate cracks, *Mapesonic 2* must be installed over 100% of the substrate that will be covered with ceramic tile or stone. For effective sound reduction, an

Mapesonic™ 2

Mapesonic²

approved acoustical sealant should fill gaps between the end of tile, vinyl or wood and the walls, columns, etc.

2. Unroll *Mapesonic 2* and cut it to size for the substrate to be tiled.
3. For easier handling and installation, each roll may be cut into shorter lengths (such as 10 feet or 3.05 m) before installation. Ensure that all edges or ends of each membrane section abut edges or ends of other sections. To ensure a flat surface and proper sound reduction, do not overlap edges or ends from one membrane section onto another.
4. Number each sheet and mark its starting point on the floor.



5. Set aside precut sections of *Mapesonic 2*.
6. With a roller or brush, prime the floor with *MAPEI SM Primer*, *MAPEI SM Primer Fast* or *MAPEI HM Primer*, according to the primer's TDS. The surface temperature of the prepared substrate must be at least 5 degrees F (2.8 degrees C) above the dew point to avoid condensation on the substrate surface as the primer dries.
7. Let the primer dry until tacky (after about 10 to 20 minutes). Confirm that the primer is sufficiently tacky before *Mapesonic 2* is installed; more than one coat may be required to achieve sufficient tack.



8. Remove 6" (15 cm) of liner from the underside of the membrane.
9. Apply the membrane (at the previously marked starting point) to the tacky substrate.



10. Continue removing short lengths of liner and applying membrane to the tacky floor until the application area is covered.
11. For a proper bond between *Mapesonic 2* and the tacky floor, roll a 75- to 100-lb. (34.0- to 45.4-kg) roller over the installed membrane. For smaller pieces of membrane, use a wood float or steel trowel to apply pressure.



12. Cut out wrinkles or trapped objects in the membrane with a razor knife, and cover the holes with small pieces of membrane.



13. Layout lines for tile, vinyl or wood can be easily applied and viewed on the light-colored membrane.



CLEANUP

- Remove excess primer with mineral spirits.

FLOORING INSTALLATION

Tile and natural stone

1. Use an appropriate MAPEI, latex, polymer-modified, tile-setting mortar meeting a minimum of ISO 13007 classification C2E and ANSI A118.4 and ANSI A118.11 industry standards. For moisture-sensitive tile or stone, use MAPEI's *Planicrete®* Wurethane adhesive.

Note: For installation of tile larger than 18" x 18" (46 x 46 cm), longer mortar-cure times may be required before tile can be grouted or walked on. For shorter turnaround times when installing larger tile, use the MAPEI rapid-set mortar *Keraflex™ RS*, *Ultraflex™ LFT™ Rapid*, *Ultracontact™ RS* or *Granirapid®*.

Glue-down wood flooring

1. Follow Steps 1 through 12 in the "Full-floor" instructions above.
2. Apply any MAPEI urethane or hybrid-polymer-based wood adhesive. Follow MAPEI's TDS instructions and recommended trowel size.

Luxury vinyl tile/plank

1. Apply MAPEI's *Ultrabond ECO® 350*, *Ultrabond ECO 360*, *Ultrabond ECO 373* or *Ultrabond ECO 399* adhesive.
2. Follow MAPEI's TDS instructions and use a 1/32" (1 mm) U-notch trowel.
3. Expect 60 to 90 minutes of flash time before installing LVT.

WATERPROOFING

- Prime the substrate first with *MAPEI SM Primer*, *MAPEI SM Primer Fast* or *MAPEI HM Primer*.
- Beneath *Mapesonic 2*, use *Mapetape BB* for sealing the seams, wall upturns and corners when waterproofing is desired. Follow all instructions on the TDS for *Mapetape BB*.

VAPOR MANAGEMENT

- Prime the substrate first with *MAPEI HM Primer*. Do not prime with *MAPEI SM Primer* or *MAPEI SM Primer Fast*.
- Beneath *Mapesonic 2*, use *Mapetape BB* for sealing the seams, wall upturns and corners when waterproofing is desired. Follow all instructions on the TDS for *Mapetape BB*.

EXPANSION JOINTS

1. Do not cover any substrate movement joints with *Mapesonic 2*, mortar or tiles. Provide for movement joints where specified. Refer to the most current TCNA Handbook for ceramic tile installation, Detail EJ171-07, or TTMAC Tile Installation Manual, Detail 301MJ.

2. When necessary, cut tiles along both edges of the expansion joints. Do not allow tile and mortar to overlap the joints.
3. Protect tilework with metal strips (edge metal) along both edges of structural building expansion joints.
4. Install the specified compressible bead and sealant into all expansion and control joints.

GROUTING

- Select an appropriate MAPEI cement grout meeting ISO 13007 classification CG2WA or CG2WAF and ANSI A118.6 or ANSI A118.7 industry standards, or an epoxy grout meeting ISO 13007 classification R2/RG or RG, as well as ANSI A118.3 industry standards. For additional information, instructions and protection recommendations, see the TDS for the MAPEI grout selected.

PROTECTION

- Provide for dry storage on site at between 40°F and 95°F (4°C and 35°C). Deliver materials at least 24 hours before application.
- Do not store *Mapesonic 2* in direct sunlight.
- Protect the installation from contamination and damage before and during tilework.
- Always provide proper protection of finished floors when heavy construction equipment (such as fork lifts or scissor lifts) is to be used over installations with sheet membrane underlayments.

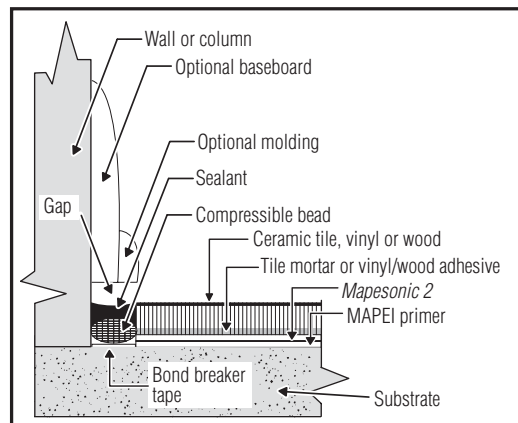

Product Performance Properties and Product Characteristics

Thickness – ASTM D5147	76 mils nominal
Maximum crack movement capacity	3/8" (10 mm) wide, in-plane
Fabric color	White
Shelf life	1 year when stored in a dry area in original, unopened packaging at 73°F (23°C)

ANSI A118.12 (Crack-Isolation Membranes for Thin-Set Ceramic Tile and Dimension Stone Installation)	<ul style="list-style-type: none"> 4.1 – Fungus and microorganism resistance: <ul style="list-style-type: none"> 4.1.2 – 14-day incubation: Pass 5.1.6 – After accelerated aging: Pass 5.2 – Point load test: <ul style="list-style-type: none"> 5.2.3 – Point load resistance after 28-day cure: Pass 5.3 – Robinson floor test ASTM C627: Pass 5.4 – System crack resistance test: <ul style="list-style-type: none"> 5.4.9 – Standard performance: Exceeds 5.4.9 – High performance: Exceeds
ANSI A118.13 (American National Standard Specification for Bonded Thin-Set Ceramic Sound Reduction Membranes for Thin-Set Ceramic Tile Installations)	<ul style="list-style-type: none"> 4.1 – Fungus and microorganism resistance: <ul style="list-style-type: none"> 4.1.2 – 14-day incubation: Pass 5.0 – Tests for system performance 5.1 – Shear strength to ceramic tiles and cement mortars <ul style="list-style-type: none"> 5.1.3 – Seven-day shear strength: Pass 5.1.4 – Seven-day water immersion shear strength: Pass 5.1.5 – Four-week shear strength: Pass 5.2 – Robinson floor test ASTM C627: Pass 5.3 – Sound transmission reduction test <ul style="list-style-type: none"> 5.3.8 – Testing according to Section 4 of ASTM E2179: Pass
ANSI A118.10 (Specifications for load-bearing, bonded, waterproof membranes for thin-set ceramic tile and dimension stone installations): When used with <i>Mapetape BB</i>	<ul style="list-style-type: none"> 4.5 – Waterproofness: Pass 4.2 – Seam strength: Pass
ASTM E-96 (Standard test methods for water vapor transmission of materials, Method A): When used with <i>Mapetape BB</i>	Vapor impermeable (0.0 perms)

	ASTM C627 Service Rating (Robinson)
	Residential and Light Commercial Applications
Measured rating	Light Commercial
MAPEI grout	<i>Keracolor[®] S</i>
12" x 12" (30 x 30 cm) solid-body, unglazed porcelain with 1/4" (6 mm) expansion joints	Yes
MAPEI mortar	<i>Ultraflex[™] 2</i>
<i>Mapesonic 2</i>	Yes
<i>MAPEI SM Primer, MAPEI SM Primer Fast or MAPEI HM Primer</i>	Yes
6" (15 cm) concrete slab	Yes

ASTM C627 Service Rating (Robinson)

MAPEI Corporation and MAPEI Inc. certify that the following Robinson tests (for tile) were conducted and warrants the systems noted.

ASTM C627 Service Rating (Robinson)	
Industrial Applications	
ASTM C627 Actual rating	Extra Heavy
MAPEI grout	Ultracolor® Plus FA
12" x 12" (30 x 30 cm) unglazed solid-body porcelain (with 1/4" or 6 mm joints)	Yes
MAPEI mortar	Ultraflex 2
Mapesonic 2	Yes
MAPEI SM Primer, MAPEI SM Primer Fast, MAPEI HM Primer	Yes
Concrete slab	Yes

ASTM Standards for Sound Reduction: MAPEI Corporation and MAPEI Inc. certify that the following sound tests (for tile) were conducted and results supplied by NGC Testing Services, Buffalo, NY. For sound-reduction ratings, higher numbers are preferred over lower numbers.

		Sound-Reduction Ratings Over 6" (15 cm) Concrete Slab			
		Luxury Vinyl Tile ¹		Solid Porcelain Tile ²	
ASTM test method	Type of sound-transmission measurement	Suspended ceiling ³	No suspended ceiling ⁴	Suspended ceiling ³	No suspended ceiling ⁴
E492-09 / E989-06 (IIC)	Impact sound	70	50	70	50
E2179-03 (Delta IIC)	Impact sound	–	20	–	21
E90-04 / E413-10 (STC)	Airborne sound	67	52	66	52

¹ 6" x 48" (15 x 122 cm) luxury vinyl tile flooring installed with Ultrabond ECO 360 (with a 1/16" x 1/32" x 1/32" [1.5 x 1 x 1 mm] U-notched trowel)

² 12" x 12" (30 x 30 cm) solid-body, unglazed porcelain tile installed with Ultraflex 2 mortar (with a 1/4" x 3/8" [6 x 10 mm] square-notched trowel) and Keracolor S grout

³ Drywall grid suspension system consisting of 5/8" (16 mm) Type X gypsum board (2.3 lbs. per sq. ft. [11.2 kg per m²] attached with screws 12" [30 cm] on center to suspended grip suspension system; and 12" [30 cm] plenum with 3-1/2" (8.9 cm) lay-in fiberglass insulation (0.16 lbs. per sq. ft. [0.78 kg per m²])

⁴ Bare concrete ceiling in room below

		Sound-Reduction Ratings Over 8" (20 cm) Concrete Slab			
		Luxury Vinyl Tile ⁵	Wood ⁶	Solid Porcelain Tile ⁷	
ASTM test method	Type of sound-transmission measurement	Suspended ceiling ⁸	No suspended ceiling ⁹	Suspended ceiling ⁸	No suspended ceiling ⁹
E492-09 / E989-06 (IIC)	Impact sound	72	49	72	50
E90-04 / E413-10 (STC)	Airborne sound	66	54	66	57

⁵ 6" x 48" (15 x 122 cm) luxury vinyl tile flooring installed with Ultrabond ECO 360 (with a 1/16" x 1/32" x 1/32" [1.5 x 1 x 1 mm] U-notched trowel)

⁶ 3/4" x 5" (19 mm x 12.5 cm) Matte Rustic hardwood flooring adhesively applied with Ultrabond ECO 980 (with a 1/4" x 1/4" x 1/4" [6 x 6 x 6 mm] square-notched trowel)

⁷ 12" x 12" (30 x 30 cm) solid-body, unglazed porcelain tile installed with Ultraflex 2 mortar (with a 1/4" x 3/8" [6 x 10 mm] square-notched trowel) and Keracolor S grout

⁸ Drywall grid suspension system consisting of 5/8" (16 mm) Type X gypsum board (2.3 lbs. per sq. ft. [11.2 kg per m²] attached with screws 12" [30 cm] on center to suspended grip suspension system; and 12" [30 cm] plenum with 3-1/2" (8.9 cm) lay-in fiberglass insulation (0.16 lbs. per sq. ft. [0.78 kg per m²])

⁹ Bare concrete ceiling in room below

Mapesonic²



Packaging and Approximate Coverage*

Product	Size	Coverage
MAPEI SM Primer Fast	Jug: 1 U.S. gal. (3.79 L)	300 to 350 sq. ft. (27.9 to 32.5 m ²)
MAPEI SM Primer	Jug: 1 U.S. gal. (3.79 L)	300 to 350 sq. ft. (27.9 to 32.5 m ²)
MAPEI SM Primer	Pail: 5 U.S. gals. (18.9 L)	1,500 to 1,750 sq. ft. (139 to 163 m ²)
MAPEI HM Primer	Jug: 1 U.S. gal. (3.79 L)	250 to 350 sq. ft. (23.2 to 32.5 m ²)
Mapesonic 2	Boxed roll: 39" x 49.2 ft. (99 cm x 15.0 m)	160 sq. ft. (14.9 m ²)

* Coverage shown is for estimating purposes only. Actual jobsite coverage depends on substrate conditions as well as the type of roller or brush used.

Primer Reference Chart

	Interior applications			Exterior applications		
	Below-grade	On-grade	Above-grade	Below-grade	On-grade	Above-grade**
MAPEI SM Primer		•	•			•
MAPEI SM Primer Fast		•	•			•
MAPEI HM Primer	•	•	•	•	•	•

** In appropriately sloped exterior environments

RELATED DOCUMENTS

Reference guide: "Surface Preparation Requirements" for tile and stone installation systems***

*** At www.mapei.com

Refer to the SDS for specific data related to health and safety as well as product handling.

For information on MAPEI's commitment to sustainability and transparency, as well as how MAPEI products may contribute to green building standards and certification systems, contact sustainability_USA@mapei.com (USA) or sustainability-durabilite@mapei.com (Canada).

LEGAL NOTICE

The contents of this Technical Data Sheet ("TDS") may be copied into another project-related document, but the resulting document shall not supplement nor replace requirements per the TDS in effect at the time of the MAPEI product installation. For the most up-to-date TDS and warranty information, please visit our website at

www.mapei.com. **ANY ALTERATIONS TO THE WORDING OR REQUIREMENTS CONTAINED IN OR DERIVED FROM THIS TDS SHALL VOID ALL RELATED MAPEI WARRANTIES.**

Before using, the user must determine the suitability of our products for the intended use,

and the user alone assumes all risks and liability. **ANY CLAIM SHALL BE DEEMED WAIVED UNLESS MADE IN WRITING TO US WITHIN FIFTEEN (15) DAYS FROM DATE IT WAS, OR REASONABLY SHOULD HAVE BEEN, DISCOVERED.**

We proudly support the following industry organizations:



MAPEI Headquarters of North America
 1144 East Newport Center Drive
 Deerfield Beach, Florida 33442
 1-888-US-MAPEI (1-888-876-2734) /
 (954) 246-8888

Technical Services
 1-800-992-6273 (U.S. and Puerto Rico)
 1-800-361-9309 (Canada)

Customer Service
 1-800-42-MAPEI (1-800-426-2734)

Services in Mexico
 0-1-800-MX-MAPEI (0-1-800-696-2734)

Edition Date: February 23, 2021
 MK 3000248 (21-1045)