

S3-N Cast in Place Stair Nosing

The **S3-N** Non-Slip Anodized Stair Nosing provides step edge colour contrast, long-lasting anti-slip protection and beautiful appearance. The S3-N provides an affordable way to renovate and modernize worn stairways and improve stairway safety.

Engineered for Durability

- The hard-wearing silicon carbide non-slip material is integrally bonded to the aluminum substrate. Thousands of people can walk on it with no signs of wear and tear.
- The thick anodized finish is aesthetically pleasing, prevents corrosion, and is extremely hard and abrasion resistant. The anodized aluminum surface is harder than pure aluminum, second only to diamonds hard crystalline structure.

Step Edge Safety

- The colour contrasting the non-slip material provides excellent step edge visibility

Environmentally Friendly

- LEED points qualified
- Recyclable; No disposable cost

For Indoor Use and Outdoor Use

- Tested to accelerated UV/weathering exposure, Salt Spray Resistance, Freeze-Thaw Resistance and Washability. Ecoglo products easily passed with excellent results.

Aluminum Finish:

- 6063-T5 Mill finish aluminum with acrylic lacquer finish to prevent corrosion.

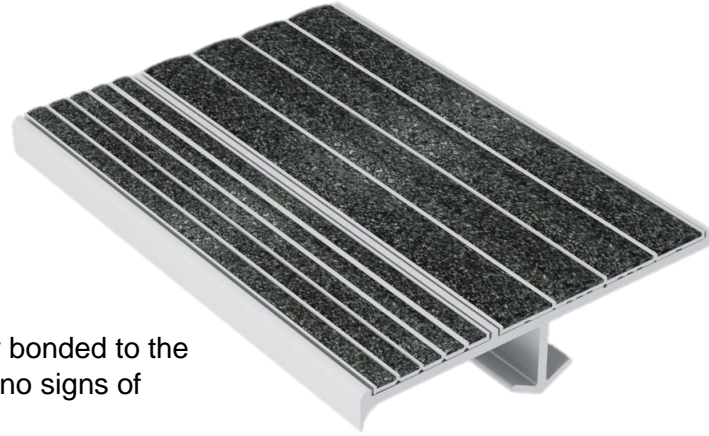

Product Colours



Black

S3070

Product Dimensions

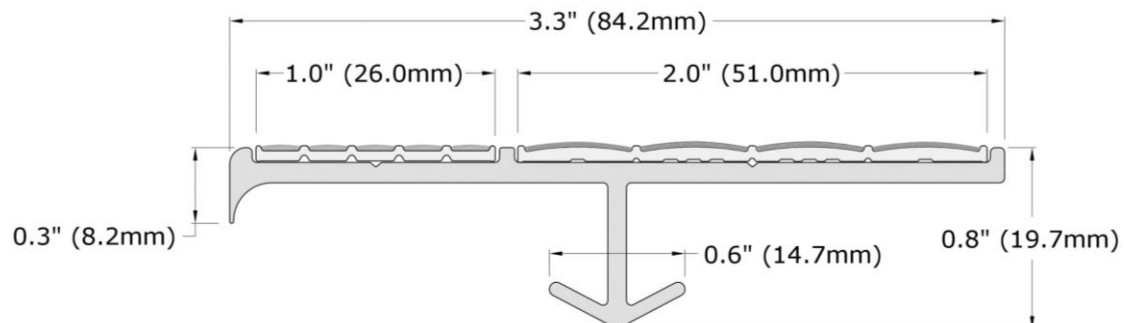

S3-N Cast in Place Stair Nosing

General Information

- Install into wet concrete. Used on concrete stairs, concrete-filled steel pan stairs, and pre-cast concrete stairs.
- Available in cut to length sizes. (Tolerance +or- 1/8") Standard lengths are 8ft and 10ft.
- Inserts Attached or Unattached – Inserts unattached can be installed later to ensure the product is clean and has not been damaged during construction. Inserts are installed with a premium polyurethane adhesive.
- A clear protective tape wraps around the product to keep it clean during installation. To remove, cut the tape along the edges and peel away.
- Weight: 0.625 lbs/ft.

The Ecoglo S3-N meets the following Building and Accessible Design Codes:

- CSA B651
- ISO/FDIS 2145

Qualifies for LEED Points

MR Credit 2: Construction Waste Management Divert from Land Fill

- Products are Aluminum based and 100% recyclable.

MR Credit 4: Recycled Content

- Products are Aluminum based and approximately 20% of the aluminum content in an Ecoglo secondary billet specification is recycled scrap.

Ecoglo's Recommended Installation Adhesive has low VOC's and qualifies for Indoor Environmental Quality credits for low emitting materials: EQc4.1

Benefits and Technical Details: Ecoglo S3-N meets or exceeds the performance criteria specified in the following tests or standards:

UV Stability

High durability indoors and outdoors.

- ASTM G155-04 Cycle 1 2000hrs, Standard Practice for Operating Xenon Arc Light Apparatus for Exposure of Nonmetallic Materials.
- Salt Spray Resistance: ASTM B117-97 500hrs, Standard Practice for Operating Salt Spray (Fog) Apparatus.
- Freeze-Thaw Resistance: ASTM C1026-87(1996), Standard Test Method for Measuring the Resistance of Ceramic Tile to Freeze-Thaw Cycling

Slip Resistant

Reduces slips.

- UL410, Standard for Slip Resistance for Floor Surface Materials.
- AS/NZS 4586-1999, Slip Resistance Classification of New Pedestrian Surface Materials.

Abrasion Resistance

Hard wearing.

- ASTM D1242-95a, Standard Test Methods for Resistance of Plastic Materials to Abrasion.
- ASTM F510-93(2004), Standard Test Method for Resistance to Abrasion of Resilient Floor Coverings Using an Abrader with a Grit Feed Method.
- JIS H8682-1:1999, Test methods for abrasion resistance of anodic oxide coatings on aluminum and aluminum alloys- Wheel wear test.

Washability

Easy Cleaning.

- ASTM D4828-94(2003), Standard Test Methods for Practical Washability of Organic Coatings.

Flammability

Does not burn.

- ASTM E162-02, Standard Test Method for Surface Flammability of Materials Using a Radiant Heat Energy Source.
- ASTM D635-03, Standard Test Method for Rate of Burning and/or Extent and Time of Burning of Plastics in a Horizontal Position.
- FAA AC 23.2 Paragraph 4.b, Horizontal Burn Test.

Contact Ecoglo Inc. for a quick quote or to obtain more information about our emergency lighting products.

Made in USA

KINESIK Engineered Products Incorporated

2213 North Sheridan Way
Mississauga, Ontario L5K 1A3
Canada

Phone: 855.364.7763
Fax: 800.769.4463
www.kinesik.ca