

BRIDGE AND JOB SITE SAW MACHINES



OVERVIEW

WET SAW – CUTTING SPECIFICATIONS GRAPHS A2

BRIDGE WET SAWS

EXPLOIT 70	A4
EXPLOIT 90	A5
EXPLOIT 120	A6
BOLT 90.....	A7
BOLT 120.....	A8
BOLT 150.....	A9
MISTRAL 90.....	A10
MISTRAL 120.....	A11
MISTRAL 150.....	A12
PIKUS 85 ADV.....	A14
PIKUS 105 ADV.....	A15
PIKUS 130 ADV.....	A16
SMS 100	A17
SMS 125	A18
SMS 150	A19
SMS 220	A20
SMS 260	A21
ZOE 85 ADV.....	A22
ZOE 105 ADV.....	A23
ZOE 130 ADV.....	A24
ZOE 150 ADV.....	A25

TROLLEY WET SAWS

SA80.....	A26
SA09	A27
SHERPA.....	A28

ACCESSORIES FOR BRIDGE WET SAWS

TILE HOLDERS, EXTENSION SIDE TABLES, FLANGES, LASERS	A30
SIDE TABLE WITH ROLLERS, SQUARES, WHEELS	A31
SIDE BENCH WITH SQUARE, WATER CONTAINMENT BARS	A32
MANUAL FEED KIT WITH WHEEL.....	A33

ACCESSORIES FOR TROLLEY WET SAWS

SQUARES, LASER, DRESSING STONES, HANDLES.....	A34
---	-----

24 models that vary in performances, technology, size and preferential intended use. This is our wide range of bridge and trolley saw machines. From the more polyvalent, suitable to cut virtually any material, to the more compact ones studied mainly for cutting porcelain tiles, until the bridge saw designed for perfect cutting of slabs up to 260 cm (102 1/3"). A vast products portfolio (supported by a wide offer of accessories) from which to choose the model that best fits the needs of every single professional. All characterized by the highest degree of quality, effectiveness and efficiency.

To identify the most suitable model, see also the machines cutting specification graphs on page A2 and A3.

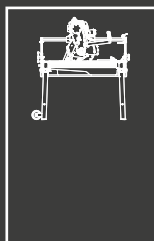



WET SAWS - CUTTING SPECIFICATIONS GRAPHS

BRIDGE AND JOB SITE SAW MACHINES

MAX LENGTH OF CUT

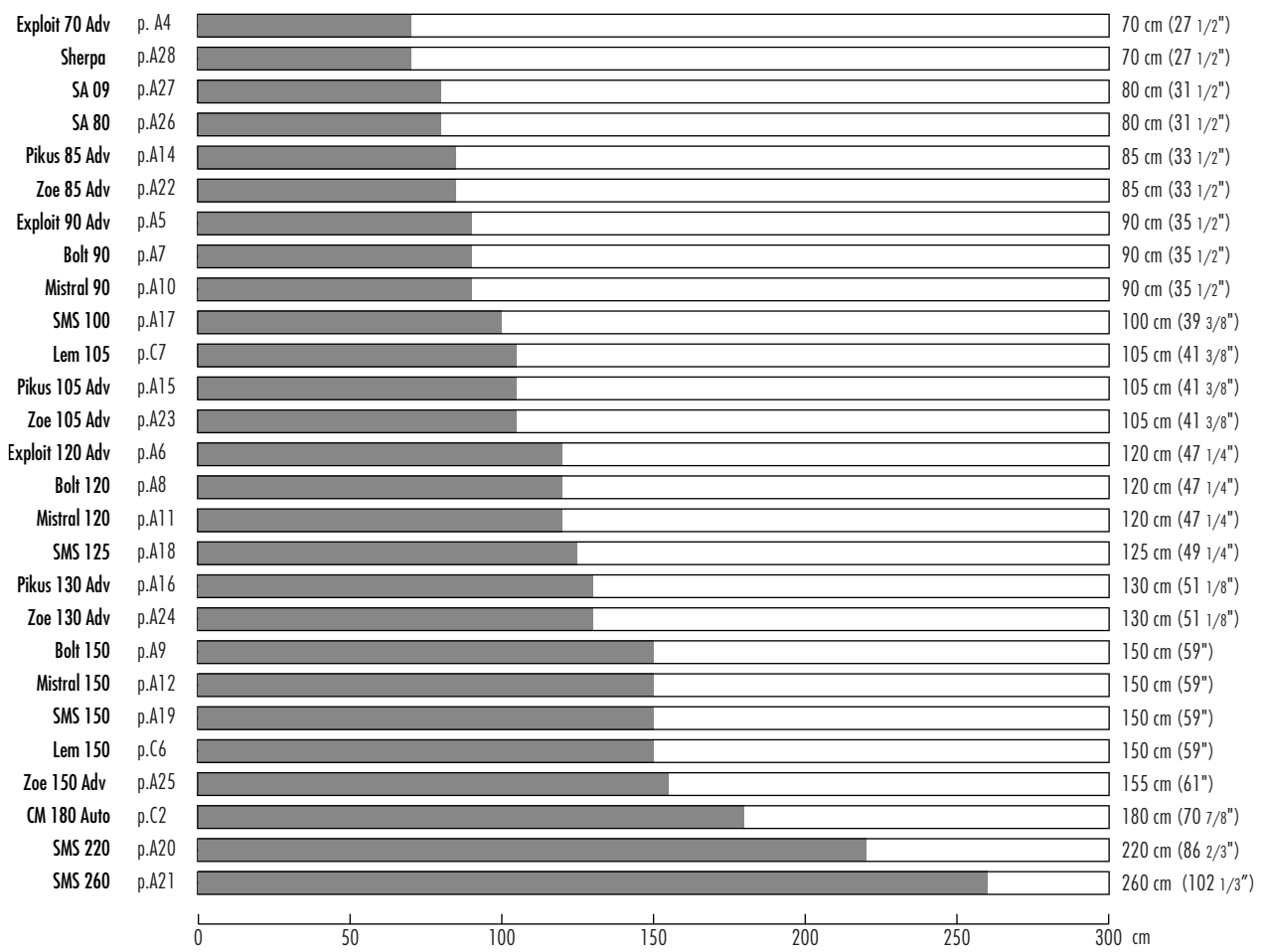

MAX DIAGONAL CUT (TILE SIZE)

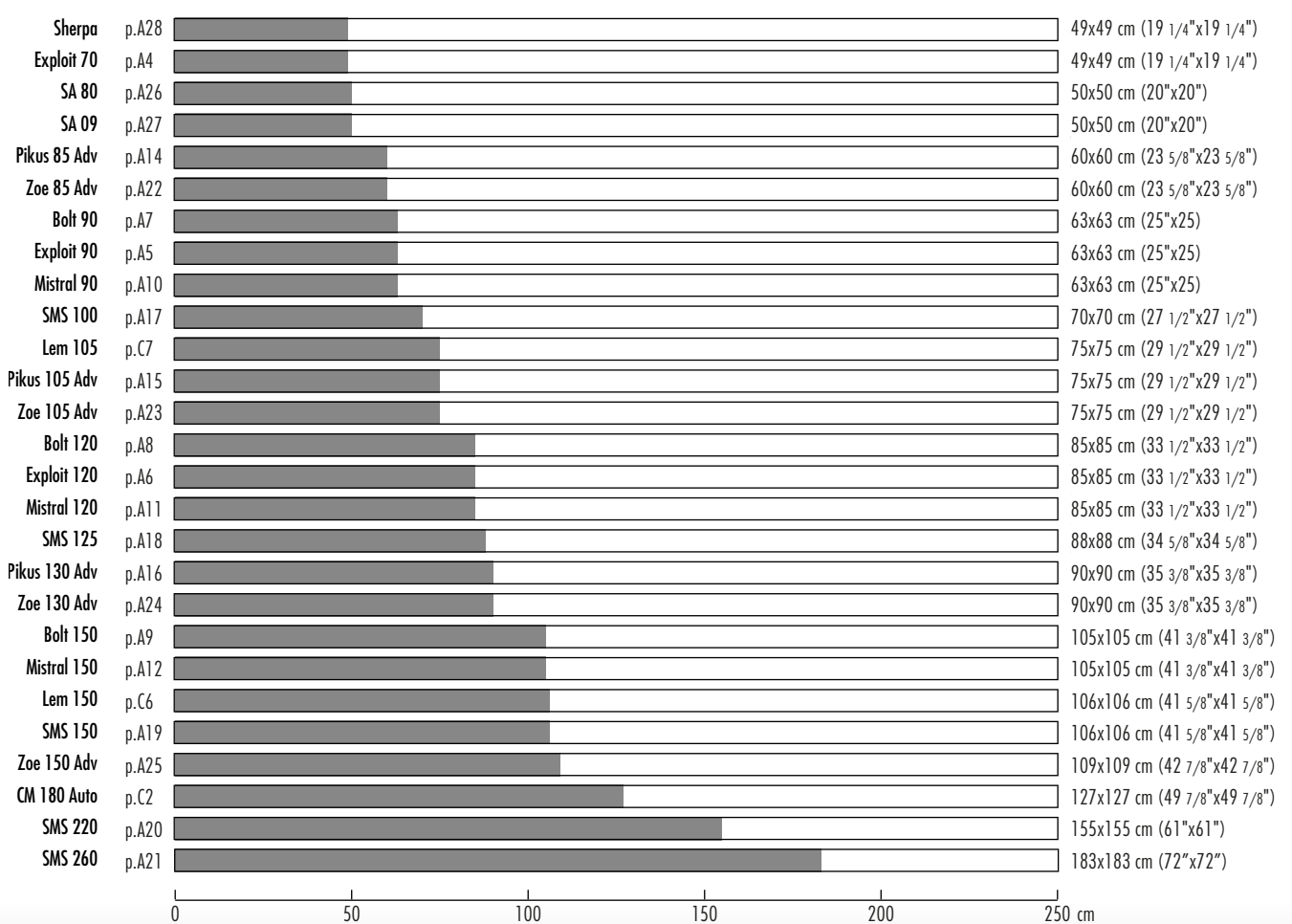



MAX THICKNESS OF CUT (SINGLE PASS)

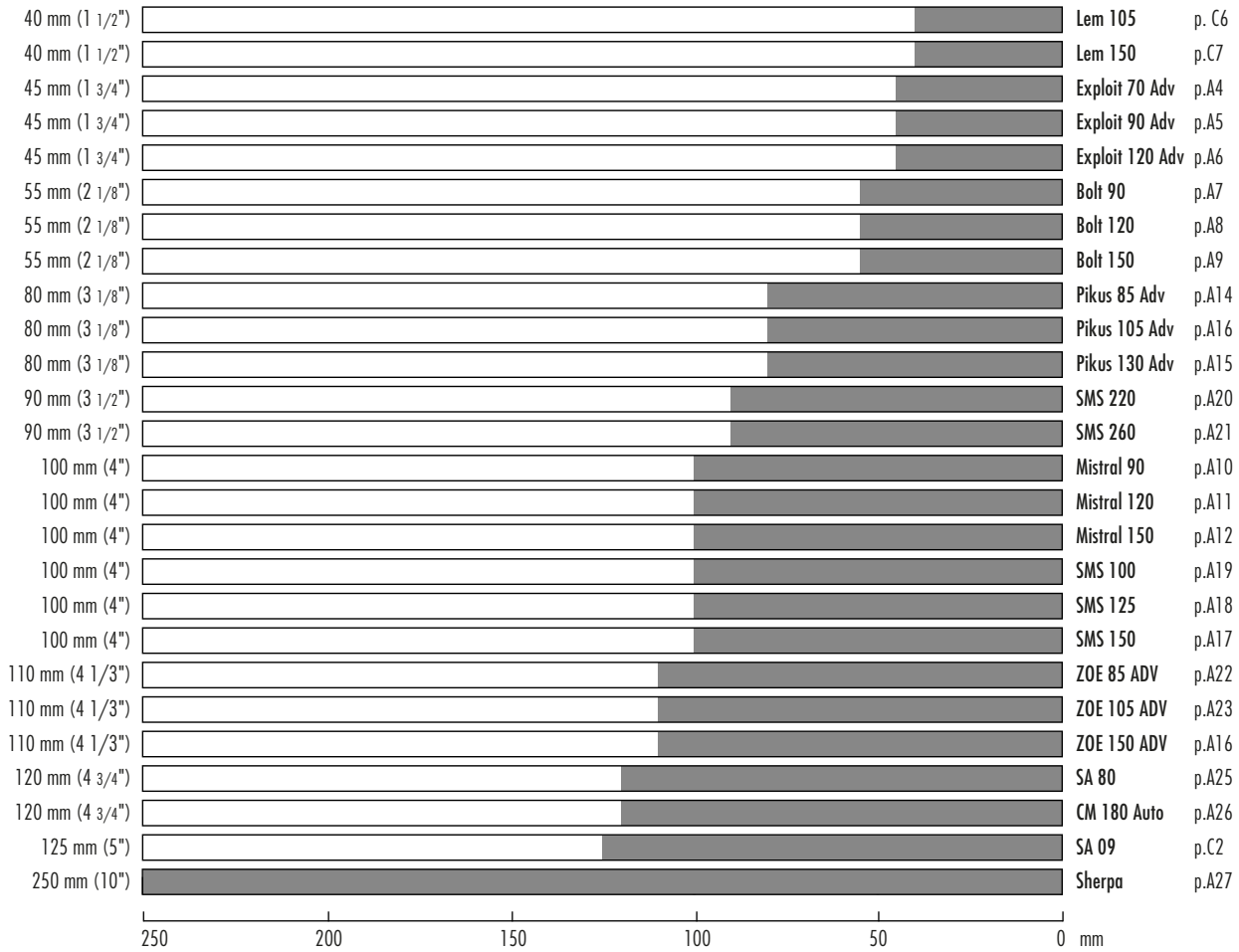

MAX THICKNESS OF CUT (DOUBLE PASS)

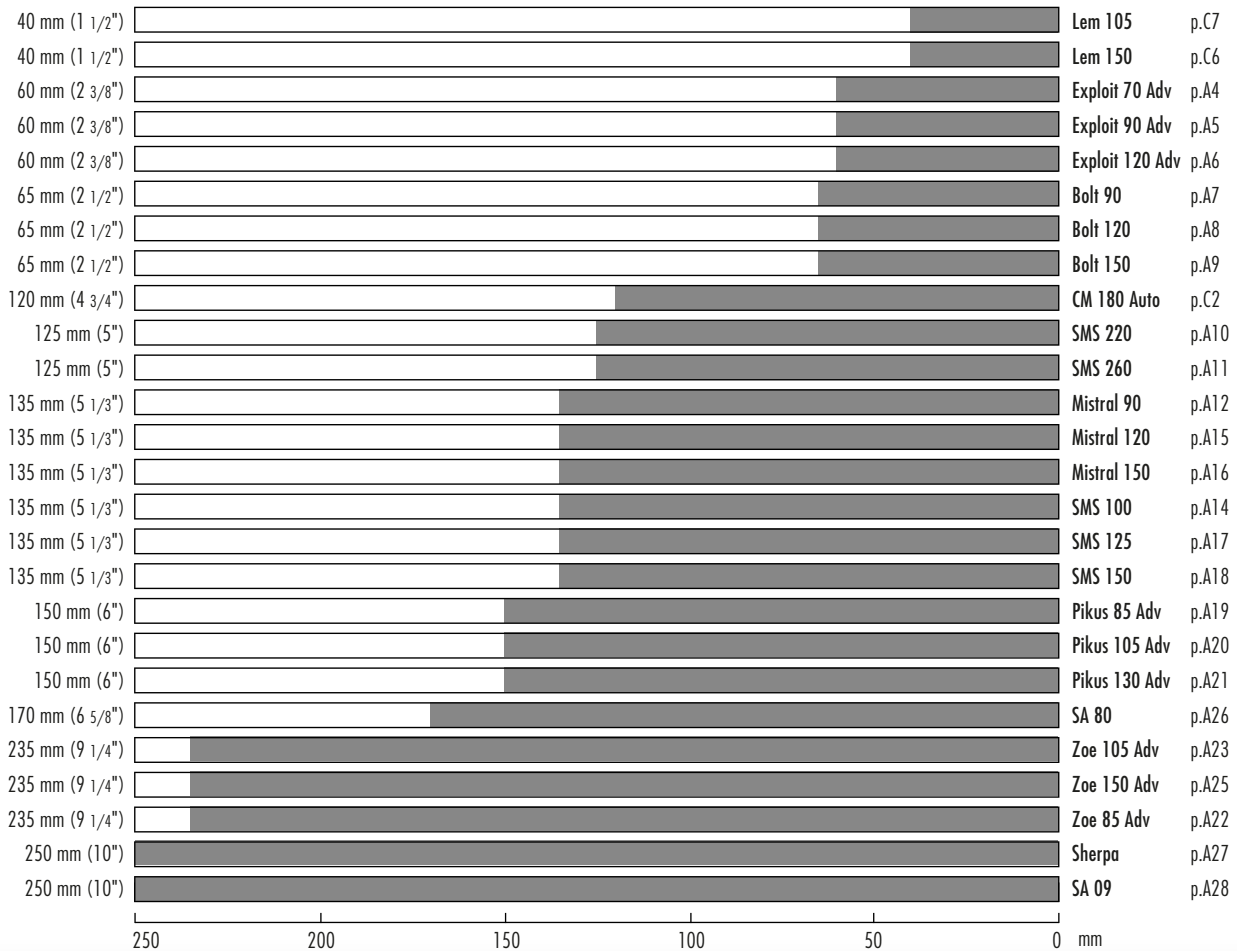

EXPLOIT 70



AVAILABLE BLADES



CONTINUAL CROWN DISC

TURBO DISC

OPTIONAL



LEFT 45°/90° SQUARE

90° SQUARE

EXTENSION BENCH WITH ROLLERS

WHEELS KIT

PACKAGE



CARTON BOX

OVERLAPABLE PALLETES

TECHNICAL CHARACTERISTICS

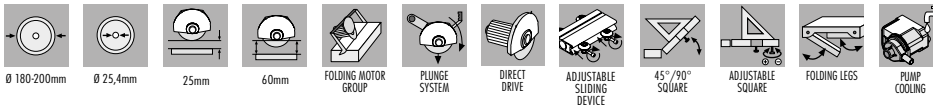

- For cutting porcelain, single-double fired, marble and granite.
- Maximum length of cut 70 cm (27 1/2").
- Maximum depth of cut: 45 mm (1 3/4") in single pass; 60 mm (2 3/8") in double pass.
- Diamond blade: max Ø 200 mm (8"); min Ø 180 mm (7").
- Plunge cut and adjustable cutting depth.
- Heavy Duty water pump.
- Sliding bar and pivots in aluminum.
- Easy-to-remove aluminum work benches for easy cleaning and maximum sturdiness.
- Coated metal frame.
- Re-adjustable aluminum square.

- Motor moves on 4 polypropylene pulleys; each pulley is reinforced with 2 inside bearings.
- Pulleys are easy to re-adjust (tighten): avoid play and confer long lasting precision of cut.
- Motor held by galvanized metal frame.
- Tiling legs.
- Tilting movement (0-47°) for 45° angle cut (jolly).
- Available accessories: self-standing side bench with rollers, 4 wheels + 2 handles kit.
- Supplied with Ø 200 mm (8") continual crown diamond disc for ceramic tiles, user manual, keys kit, dressing stone.

MODEL SPECIFICATIONS

Part No.	Barcode	Carton	Lightning Bolt	Motor	Motor	Motor	Blade	Blade	
393N 070EU	8024648089366	1	230 V 50 Hz	Single-phase	0,9 HP / 0,65 kW	2800	200 mm	8"	2800
393N 070BR	8024648091017	1	230 V 60 Hz	Single-phase	0,9 HP / 0,65 kW	3360	200 mm	8"	3360
393N 070US	8024648089380	1	110 V 60 Hz	Single-phase	0,9 HP / 0,65 kW	3360	200 mm	8"	3360
393N 070GB	8024648089373	1	110 V 50 Hz	Single-phase	0,9 HP / 0,65 kW	2800	200 mm	8"	2800

CUTTING SPECIFICATIONS AND MACHINE DIMENSIONS / WEIGHT

Model	Blade	Blade	Blade	Blade	Blade	Blade	Blade	Blade	Blade	Blade	Blade	Blade	
EXPLOIT 70	200 mm	8"	45 mm	1 3/4"	25 mm	1"	70 cm	∞	49x49 cm	100x56x h50 cm	34 Kg	101x57 h41 cm	36 Kg
	180 mm	7"	35 mm	1 3/8"	-	-	27 1/2"		19 1/2" x 19 1/2"	39 3/8" x 22" x h19 5/8"	75 lbs	39 3/4" x 22 1/2" x h16 1/8"	79.4 lbs





BRIDGE AND JOB SITE SAW MACHINES



AVAILABLE BLADES

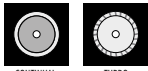

CONTINUAL CROWN DISC TURBO DISC

OPTIONAL



LEFT 45°/90° SQUARE 90° SQUARE EXTENSION BENCH WITH ROLLERS CUTTING GUIDE WHEELS KIT

PACKAGE



CARTON BOX ON PALLET OVERLAPPING PALLETS

TECHNICAL CHARACTERISTICS

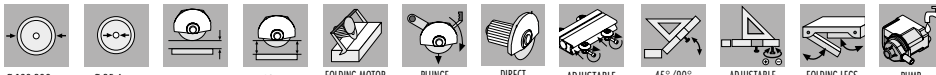

Ø 180-200mm Ø 25,4mm 25mm 60mm FOLDING MOTOR GROUP PLUNGE SYSTEM DIRECT DRIVE ADJUSTABLE SLIDING DEVICE 45°/90° SQUARE ADJUSTABLE SQUARE FOLDING LEGS PUMP COOLING

- For cutting porcelain, single-double fired, marble and granite.
- Maximum length of cut 90 cm (35 1/2").
- Maximum depth of cut 45 mm (1 3/4") in single pass; 60 mm (2 3/8") in double pass.
- Diamond blade: max Ø 200 mm (8"); min Ø 180 mm (7").
- Plunge cut and adjustable cutting depth.
- Heavy Duty water pump.
- Sliding bar and pivots in aluminum.
- Easy-to-remove aluminum work benches for easy cleaning and maximum sturdiness.
- Coated metal frame.
- Re-adjustable aluminum square.

- Motor moves on 4 polypropylene pulleys.; each pulley is reinforced with 2 inside bearings.
- Pulleys are easy to re-adjust (tighten): avoid play and confer long lasting precision of cut.
- Motor held by galvanized metal frame.
- Tiling legs.
- Tilting movement (0-47°) for 45° angle cut (jolly).
- Available accessories: extra side square, self-standing side bench with rollers, 4 wheels + 2 handles kit.
- Supplied with Ø 200 mm (8") continual crown diamond disc for ceramic tiles, user manual, keys kit, dressing stone.

MODEL SPECIFICATIONS

Part No.	Barcode	Box	Lightning Bolt	M	Motor	Motor	Disc	Disc
393N 090EU	8024648089397	1	230 V 50 Hz	Single-phase	0,9 HP / 0,65 kW	2800	200 mm 8"	2800
393N 090BR	8024648091031	1	230 V 60 Hz	Single-phase	0,9 HP / 0,65 kW	3360	200 mm 8"	3360
393N 090US	8024648089410	1	110 V 60 Hz	Single-phase	0,9 HP / 0,65 kW	3360	200 mm 8"	3360
393N 090GB	8024648089403	1	110 V 50 Hz	Single-phase	0,9 HP / 0,65 kW	2800	200 mm 8"	2800

CUTTING SPECIFICATIONS AND MACHINE DIMENSIONS / WEIGHT

Model	Blade	Blade	Blade	Blade	Blade	Blade	Blade	Blade	Blade	Blade	Blade	Blade
EXPLOIT 90	200 mm 8"	45 mm 1 3/4"	25 mm 1"	90 cm 35 1/2"	∞	63x63 cm 25"x25"	125x56x h50 cm 49 1/4"x22"x h19 5/8"	35 Kg 77.2 lbs	130x58 h55 cm 51 1/8"x23"x h 21 5/8"	45 Kg 99.2 lbs		



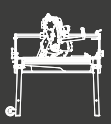

BRIDGE AND JOB SITE SAW MACHINES

EXPLOIT 120



AVAILABLE BLADES



CONTINUAL CROWN DISC

TURBO DISC

OPTIONAL



LEFT 45°/90° SQUARE

90° SQUARE

EXTENSION BENCH WITH ROLLERS

CUTTING GUIDE

WHEELS KIT

PACKAGE



WOODEN CASE

OVERLAPABLE PALLETS

TECHNICAL CHARACTERISTICS

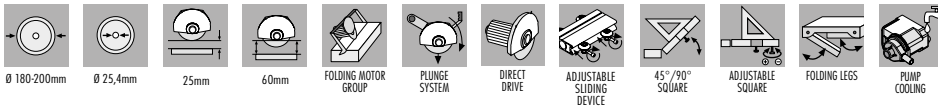

- For cutting porcelain, single-double fired, marble and granite.
- Maximum length of cut 120 cm (47 1/4").
- Maximum depth of cut 45 mm (1 3/4") in single pass; 60 mm (2 3/8") in double pass.
- Diamond blade: max Ø 200 mm (8"); min Ø 180 mm (7").
- Plunge cut and adjustable cutting depth.
- Heavy Duty water pump.
- Sliding bar and pivots in aluminum.
- Easy-to-remove aluminum work benches for easy cleaning and maximum sturdiness.
- Coated metal frame.
- Re-adjustable aluminum square.

- Motor moves on 4 polypropylene pulleys.; each pulley is reinforced with 2 inside bearings.
- Pulleys are easy to re-adjust (tighten): avoid play and confer long lasting precision of cut.
- Motor held by galvanized metal frame.
- Tiling legs.
- Tilting movement (0-47°) for 45° angle cut (jolly).
- Available accessories: extra side square, self-standing side bench with rollers, 4 wheels + 2 handles kit.
- Supplied with Ø 200 mm (8") continual crown diamond disc for ceramic tiles, user manual, keys kit, dressing stone.

MODEL SPECIFICATIONS

Part No.	Barcode	Box	Lightning Bolt	M	Motor	Motor	Blade	Blade
393N 120EU	8024648095664	1	230 V 50 Hz	Single-phase	1,2 HP / 0,9 kW	2800	200 mm 8"	2800
393N 120BR	8024648095893	1	230 V 60 Hz	Single-phase	1,2 HP / 0,9 kW	3360	200 mm 8"	3360
393N 120US	8024648095701	1	110 V 60 Hz	Single-phase	1,2 HP / 0,9 kW	3360	200 mm 8"	3360
393N 120GB	8024648095909	1	110 V 50 Hz	Single-phase	1,2 HP / 0,9 kW	2800	200 mm 8"	2800

CUTTING SPECIFICATIONS AND MACHINE DIMENSIONS / WEIGHT

Model	Blade	Blade	Blade	Blade	Blade	Blade	Blade	Blade	Blade	Blade	Blade	Blade
EXPLOIT 120	200 mm 8"	180 mm 7"	45 mm 1 3/4"	25 mm 1"	60 mm 2 3/8"	120 cm 47 1/4"	∞	85x85 cm 33 1/2"x33 1/2"	155x70xh 50 cm 61"x27"xh 20"	46 Kg 101.4 lbs	165x65xh 55 cm 65"x25 1/2"xh 21 5/8"	62 Kg 136.7 lbs



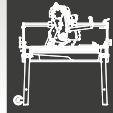

AVAILABLE BLADES

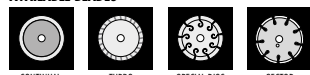

CONTINUAL CROWN DISC TURBO DISC SPECIAL DISC FOR PORCELAIN SECTOR DISC

OPTIONAL



LEFT 45°/90° SQUARE 90° SQUARE EXTENSION BENCH WITH ROLLERS CUTTING GUIDE WHEELS KIT

PACKAGE



CARTON BOX ON PALLET OVERLAPABLE PALLETES

TECHNICAL CHARACTERISTICS

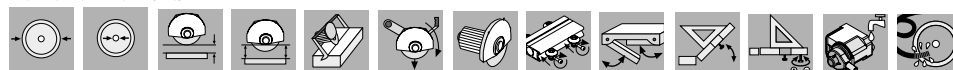

Ø 250mm Ø 254mm 18mm 65mm FOLDING MOTOR GROUP PLUNGE SYSTEM DIRECT DRIVE ADJUSTABLE SLIDING DEVICE FOLDING LEGS 45°/90° SQUARE ADJUSTABLE SQUARE PUMP COOLING MULTI JET WET COOLING

- For cutting porcelain, single-double fired, marble and granite.
- Maximum length of cut 90 cm (35 1/2").
- Maximum depth of cut 55 mm (2 1/8") in single pass; 65 mm (2 1/2") in double pass.
- Diamond blade Ø 250 mm (10").
- Plunge cut and adjustable cutting depth.
- Heavy Duty water pump. High capacity double jet water cooling.
- Sliding bar, pivots and disc cover in aluminum.
- Easy-to-remove aluminum work benches for easy cleaning and maximum sturdiness.
- Coated metal frame.
- Re-adjustable aluminum square.

- Motor moves on 4 polypropylene pulleys; each pulley is reinforced with 2 inside bearings.
- Pulleys are easy to re-adjust (tighten): avoid play and confer long lasting precision of cut.
- Motor held by galvanized metal frame.
- Tiling legs.
- Tilting movement (0-47°) for 45° angle cut (jolly).
- Available accessories: extra side square, self-standing side bench with rollers, 4 wheels + 2 handles kit.
- Supplied with Ø 250 mm (10") diamond disc for porcelain tiles, user manual, keys kit, dressing stone.

MODEL SPECIFICATIONS

Part No.	Barcode	Box	Lightning Bolt	M	Motor	Motor	Blade	Blade
225MS 90EU	8024648088659	1	230 V 50 Hz	Single-phase	1,5 HP / 1,1 kW	2800	250 mm 10"	2800
225MS 90BR	8024648089717	1	230 V 60 Hz	Single-phase	1,5 HP / 1,1 kW	3360	250 mm 10"	3360
225MS 90US	8024648089731	1	110 V 60 Hz	Single-phase	1,5 HP / 1,1 kW	3360	250 mm 10"	3360
225MS 90GB	8024648089724	1	110 V 50 Hz	Single-phase	1,5 HP / 1,1 kW	2800	250 mm 10"	2800

CUTTING SPECIFICATIONS AND MACHINE DIMENSIONS / WEIGHT

Model	Blade	Depth	Depth	Length	Width	Table	Table	Weight	Table	Weight
BOLT 90	250 mm 10"	55 mm 2 1/8"	30 mm 1 3/16"	90 cm 35 1/2"	∞	63x63 cm 25"x25"	120x56x h50 cm 47 1/4"x22"x h19 5/8"	46 Kg 101.4 lbs	130x58xh 55 cm 51 1/8"x23"xh21 5/8"	56 Kg 123.5 lbs



BOLT 120



AVAILABLE BLADES



TECHNICAL CHARACTERISTICS

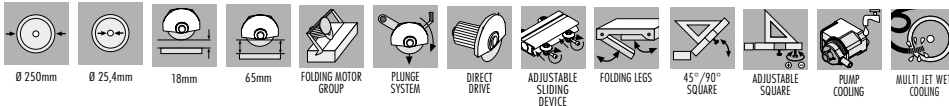

OPTIONAL



PACKAGE



- For cutting porcelain, single-double fired, marble and granite.
- Maximum length of cut 120 cm (47 1/4").
- Maximum depth of cut 55 mm (2 1/8") in single pass; 65 mm (2 1/2") in double pass.
- Diamond blade Ø 250 mm (10").
- Plunge cut and adjustable cutting depth.
- Heavy Duty water pump. High capacity double jet water cooling.
- Sliding bar, pivots and disc cover in aluminum.
- Easy-to-remove aluminum work benches for easy cleaning and maximum sturdiness.
- Coated metal frame.
- Re-adjustable aluminum square.

- Motor moves on 4 polypropylene pulleys.; each pulley is reinforced with 2 inside bearings.
- Pulleys are easy to re-adjust (tighten): avoid play and confer long lasting precision of cut.
- Motor held by galvanized metal frame.
- Tiling legs.
- Tilting movement (0-47°) for 45° angle cut (jolly).
- Available accessories: extra side square, self-standing side bench with rollers, 4 wheels + 2 handles kit, wheel feed kit.
- Supplied with Ø 250 mm (10") diamond disc for porcelain tiles, user manual, keys kit, dressing stone.

MODEL SPECIFICATIONS

Part No.	Barcode	Box	Lightning Bolt	M	Motor	Weight	Blade	Blade	
225MS 120EU	8024648088673	1	230 V 50 Hz	Single-phase	1,5 HP / 1,1 kW	2800	250 mm	10"	2800
225MS 120BR	8024648089755	1	230 V 60 Hz	Single-phase	1,5 HP / 1,1 kW	3360	250 mm	10"	3360
225MS 120US	8024648089779	1	110 V 60 Hz	Single-phase	1,5 HP / 1,1 kW	3360	250 mm	10"	3360
225MS 120GB	8024648089762	1	110 V 50 Hz	Single-phase	1,5 HP / 1,1 kW	2800	250 mm	10"	2800

CUTTING SPECIFICATIONS AND MACHINE DIMENSIONS / WEIGHT

Model	Blade Diameter	Max Depth	Min Depth	Max Length	Max Width	Table Size	Table Height	Weight	Table Size	Weight
BOLT 120	250 mm 10"	55 mm 2 1/8"	30 mm 1 3/16"	120 cm 47 1/4"	∞	85x85 cm 33 1/2"x33 1/2"	150x56x h50 cm 59"x22"x h19 5/8"	50 Kg 110.2 lbs	165x65xh 55 cm 65"x25 1/2"xh21 5/8"	66 Kg 145.5 lbs



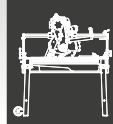

BRIDGE AND JOB SITE SAW MACHINES



AVAILABLE BLADES

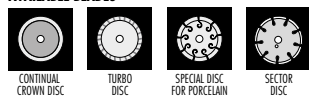

OPTIONAL

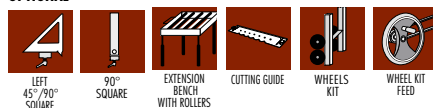

PACKAGE

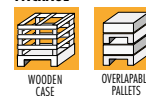

TECHNICAL CHARACTERISTICS

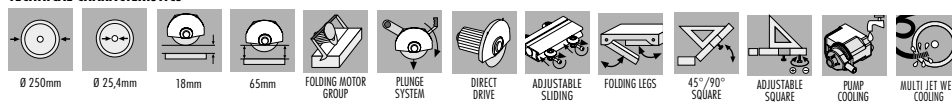

- For cutting porcelain, single-double fired, marble and granite.
- Maximum length of cut 150 cm (59").
- Maximum depth of cut 55 mm (2 1/8") in single pass; 65 mm (2 1/2") in double pass.
- Diamond blade Ø 250 mm (10").
- Plunge cut and adjustable cutting depth.
- Heavy Duty water pump. High capacity double jet water cooling.
- Sliding bar, pivots and disc cover in aluminum.
- Easy-to-remove aluminum work benches for easy cleaning and maximum sturdiness.
- Coated metal frame.
- Re-adjustable aluminum square.
- Motor moves on 4 polypropylene pulleys.; each pulley is reinforced with 2 inside bearings.
- Pulleys are easy to re-adjust (tighten): avoid play and confer long lasting precision of cut.
- Motor held by galvanized metal frame.
- Tiling legs.
- Tilting movement (0-47°) for 45° angle cut (jolly).
- Available accessories: extra side square, self-standing side bench with rollers , 4 wheels + 2 handles kit, wheel feed kit.
- Supplied with Ø 250 mm (10") diamond disc for porcelain tiles, user manual, keys kit, dressing stone.

MODEL SPECIFICATIONS

Part No.	Barcode	Box	Lightning Bolt	M	Motor	Motor	Blade	Blade	
225MS 150EU	8024648089809	1	230 V 50 Hz	Single-phase	1,5 HP / 1,1 kW	2800	250 mm	10"	2800
225MS 150BR	8024648089793	1	230 V 60 Hz	Single-phase	1,5 HP / 1,1 kW	3360	250 mm	10"	3360
225MS 150US	8024648089823	1	110 V 60 Hz	Single-phase	1,5 HP / 1,1 kW	3360	250 mm	10"	3360
225MS 150GB	8024648089816	1	110 V 50 Hz	Single-phase	1,5 HP / 1,1 kW	2800	250 mm	10"	2800

CUTTING SPECIFICATIONS AND MACHINE DIMENSIONS / WEIGHT

Model	Blade	Depth	Depth	Length	Width	Table	Table	Weight	Weight	Weight
BOLT 150	250 mm 10"	55 mm 2 1/8"	30 mm 1 3/16"	150 cm 59"	∞	105x105 cm 41 3/8" x 41 3/8"	180x56X h50 cm 71"x22"x h19 5/8"	56 Kg 123.5 lbs	195x65x h55 cm 76 3/4"x25 1/2"x h 21 5/8"	72 Kg 158.7 lbs



MISTRAL 90



AVAILABLE BLADES



TECHNICAL CHARACTERISTICS

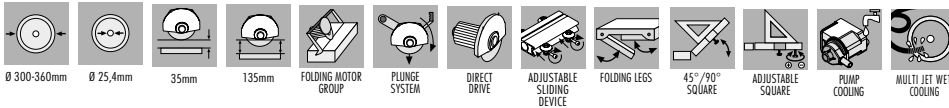

OPTIONAL

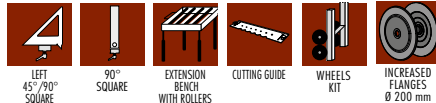

PACKAGE

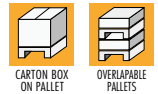

- For cutting porcelain, single-double fired, marble and granite.
- Maximum length of cut 90 cm (35 1/2").
- Maximum depth of cut 100 mm (4") in single pass; 135 mm (5 1/8") in double pass.
- Diamond blade max Ø 350 mm (14"); min Ø 300 mm (12").
- Plunge cut and adjustable cutting depth.
- Heavy Duty water pump. High capacity double jet water cooling.
- Sliding bar and disc cover in aluminum.
- Easy-to-remove aluminum work benches for easy cleaning and maximum sturdiness.
- Coated metal frame.
- Re-adjustable aluminum square.
- Motor moves on 4 polypropylene pulleys; each pulley is reinforced with 2 inside bearings.

- Pulleys are easy to re-adjust (tighten): avoid play and confer long lasting precision of cut.
- Motor assembly holder and pivots in galvanized steel.
- Tiling legs.
- Tilting movement (0-47°) for 45° angle cut (jolly).
- Available accessories: extra side square, self-standing side bench with rollers, 4 wheels + 2 handles kit.
- Supplied with Ø 350 mm (14") diamond disc for porcelain tiles, user manual, keys kit, dressing stone.

MODEL SPECIFICATIONS

Part No.	Barcode	Box	Lightning Bolt	M	Motor	Motor	Disc	Disc	Disc
224MS 90EU	8024648088611	1	230V 50 Hz	Single-phase	3 HP / 2,2 kW	2800	350 mm	14"	2800
224MS 90BR	8024648090492	1	230V 60 Hz	Single-phase	3 HP / 2,2 kW	3360	350 mm	14"	3360
224MS 90US	8024648090508	1	110V 60 Hz	Single-phase	2 HP / 1,5 kW	3360	350 mm	14"	3360

CUTTING SPECIFICATIONS AND MACHINE DIMENSIONS / WEIGHT

Model	Disc	Depth	Depth	Depth	Depth	Depth	Motor	Weight	Dimensions	Weight
MISTRAL 90	350 mm 14"	100 mm 4"	60 mm 2 3/8"	90 cm 35 1/2"	∞	63x63 cm 25"x25"	120x60x h60 cm 47 1/4"x23 5/8"x h23 5/8"	60 Kg 132.3 lbs	130x58x h72 cm 51 1/8"x22 3/4"x h 28 3/8"	70 Kg 154.3 lbs





BRIDGE AND JOB SITE SAW MACHINES



AVAILABLE BLADES

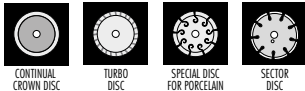

OPTIONAL



PACKAGE



TECHNICAL CHARACTERISTICS

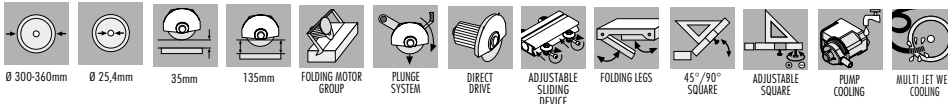

- For cutting porcelain, single-double fired, marble and granite.
- Maximum length of cut 120 cm (47 1/4").
- Maximum depth of cut 100 mm (4") in single pass; 135 mm (5 1/3") in double pass.
- Diamond blade max Ø 350 mm (14"); min Ø 300 mm (12").
- Plunge cut and adjustable cutting depth.
- Heavy Duty water pump. High capacity double jet water cooling.
- Sliding bar and disc cover in aluminum.
- Easy-to-remove aluminum work benches for easy cleaning and maximum sturdiness.
- Coated metal frame.
- Re-adjustable aluminum square.
- Motor moves on 4 polypropylene pulleys.; each pulley is reinforced with 2 inside bearings.

- Pulleys are easy to re-adjust (tighten): avoid play and confer long lasting precision of cut.
- Motor assembly holder and pivots in galvanized steel.
- Tiling legs.
- Tilting movement (0-47°) for 45° angle cut (jolly).
- Available accessories: extra side square, self-standing side bench with rollers 4 wheels + 2 handles kit, wheel kit feed.
- Supplied with Ø 350 mm (14") diamond disc for porcelain tiles, user manual, keys kit, dressing stone.

MODEL SPECIFICATIONS

Part No.									
224MS 120EU	8024648088628	1	230V 50 Hz	Single-phase	3 HP / 2,2 kW	2800	350 mm	14"	2800
224MS 120BR	8024648090522	1	230V 60 Hz	Single-phase	3 HP / 2,2 kW	3360	350 mm	14"	3360
224MS 120US	8024648090539	1	110V 60 Hz	Single-phase	2 HP / 1,5 kW	3360	350 mm	14"	3360

CUTTING SPECIFICATIONS AND MACHINE DIMENSIONS / WEIGHT

Model										
MISTRAL 120	350 mm 14"	100 mm 4"	60 mm 2 3/8"	120 cm 47 1/4"	∞	85x85 cm 33 1/2" x 33 1/2"	150x60x h60 cm 59" x 23 5/8" x h 23 5/8"	63 Kg 138.9 lbs	165x65x h72 cm 65" x 25 1/2" x h 28 3/8"	83 Kg 183 lbs



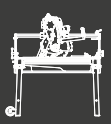

MISTRAL 150



AVAILABLE BLADES

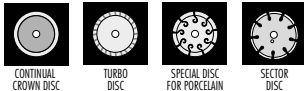

OPTIONAL



PACKAGE

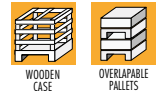

TECHNICAL CHARACTERISTICS

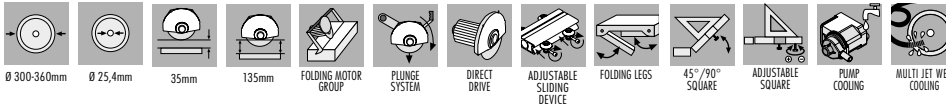

- For cutting porcelain, single-double fired, marble and granite.
- Maximum length of cut 150 cm (59").
- Maximum depth of cut 100 mm (4") in single pass; 135 mm (5 1/3") in double pass.
- Diamond blade max Ø 350 mm (14"); min Ø 300 mm (12").
- Plunge cut and adjustable cutting depth.
- Heavy Duty water pump. High capacity double jet water cooling.
- Sliding bar and disc cover in aluminum.
- Easy-to-remove aluminum work benches for easy cleaning and maximum sturdiness.
- Coated metal frame.
- Re-adjustable aluminum square.
- Motor moves on 4 polypropylene pulleys.; each pulley is reinforced with 2 inside bearings.

- Pulleys are easy to re-adjust (tighten): avoid play and confer long lasting precision of cut.
- Motor assembly holder and pivots in galvanized steel.
- Tiling legs.
- Tilting movement (0-47°) for 45° angle cut (jolly).
- Available accessories: extra side square, self-standing side bench with rollers 4 wheels + 2 handles kit, wheel kit feed.
- Supplied with ø 350 mm (14") diamond disc for porcelain tiles, user manual, keys kit, dressing stone.

MODEL SPECIFICATIONS

Part No.	Barcode	Box	Lightning Bolt	M	Motor	Motor	Disc	Disc	
224MS 150EU	8024648088635	1	230V 50 Hz	Single-phase	3 HP / 2,2 kW	2800	350 mm	14"	2800
224MS 150BR	8024648090553	1	230V 60 Hz	Single-phase	3 HP / 2,2 kW	3360	350 mm	14"	3360
224MS 150US	8024648090560	1	110V 60 Hz	Single-phase	2 HP / 1,5 kW	3360	350 mm	14"	3360

CUTTING SPECIFICATIONS AND MACHINE DIMENSIONS / WEIGHT

Model	Disc	Depth	Width	Length	Wheels	Table	Motor	Weight	Dimensions	Weight
MISTRAL 150	350 mm 14"	100 mm 4"	60 mm 2 3/8"	150 cm 59"	∞	105x105 cm 41 3/8" x 41 3/8"	180x60x h60 cm 71" x 23 5/8" x h23 5/8"	73 Kg 160.9 lbs	195x65x h72 cm 77" x 25 1/2" x h 28 3/8"	90 Kg 198.4 lbs





BRIDGE AND JOB SITE SAW MACHINES

AVAILABLE BLADES

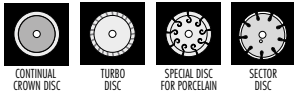

OPTIONAL

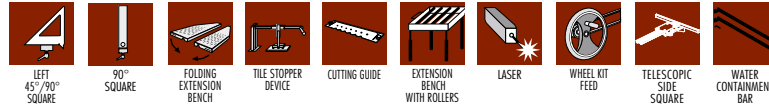

PACKAGE

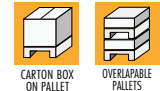

TECHNICAL CHARACTERISTICS

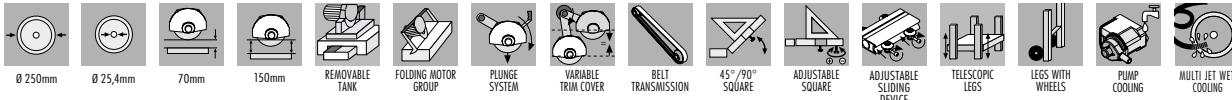

- For cutting granite, marble, porcelain, single and double fired, bricks, cement, etc...
- Maximum length of cut 85 cm (33 1/2").
- Maximum thickness of cut: 80 mm (3 1/8") in single pass; 150 mm (6") in double pass.
- Maximum blade diameter Ø 250 mm (10"); smallest blade diameter Ø 230 mm (9").
- Adjustable cutting depth.
- Tilting motor assembly for bevel cuts from 0° to 45°.
- Belt driven system optimizes motor torque and cutting capacity.
Gear ratio of motor to disc 1,4 ÷ 1. Drive belt type poly V.
- Cast and extruded aluminum framework.
- Easy-to-remove polypropylene tank for easy cleaning. Capacity: 38 lt (10 Gal).

- Heavy duty water pump and (2) jet nozzles (front or rear mounted) provide superior blade cooling.
- Sliding motor assembly with cast aluminum housing provided with 4 re-adjustable pulleys (double bearings). Extruded aluminum rail.
- Re-adjustable square for long lasting precision.
- Telescopic legs provided with double safety device to prevent collapsing.
- Floating blade guard remains in contact with tile to provide extra safety during operation.
- Pivoting blade guard remains parallel to tile to ensure maximum cutting depth.
- Equipped with: diamond disc Ø 250 mm (10") for porcelain, wheels kit for easy transport, key kit, wrench, manual.

MODEL SPECIFICATIONS

Part No.	Barcode	Box	Lightning Bolt	M	Motor	Motor	Blade	Blade	
424ADV	8024648054791	1	230 V 50Hz	Single-phase	1,5 HP / 1,1 kW	2800	250 mm	10"	2000
424ADV 60	8024648055941	1	230 V 60Hz	Single-phase	1,5 HP / 1,1 kW	3360	250 mm	10"	2400
424ADV US	8024648054807	1	110 V 60Hz	Single-phase	1,3 HP / 1 kW	3360	250 mm	10"	2400
424ADV GB	8024648055934	1	115 V 50Hz	Single-phase	1,5 HP / 1,1 kW	2800	250 mm	10"	2000

CUTTING SPECIFICATIONS AND MACHINE DIMENSIONS / WEIGHT

Model	Blade	Thickness	Thickness	Length	Length	Table	Table	Weight	Weight	Weight
PIKUS 85 ADV	250 mm 10"	80 mm 3 1/8"	55 mm 2 1/8"	85 cm 33 1/2"	∞	60x60 cm 23 5/8"x23 5/8"	125x70xh 79 cm 50"x27"x h 31"	60 Kg 132.3 lbs	150x73xh 95cm 59"x29"x h 37"	78 Kg 172 lbs



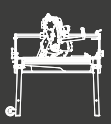

BRIDGE AND JOB SITE SAW MACHINES

PIKUS 105 ADVANCED

-
-
-
-
-



AVAILABLE BLADES

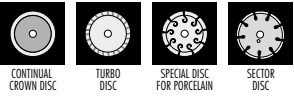

OPTIONAL

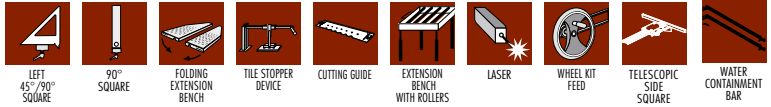

PACKAGE

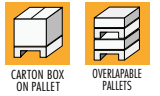

TECHNICAL CHARACTERISTICS

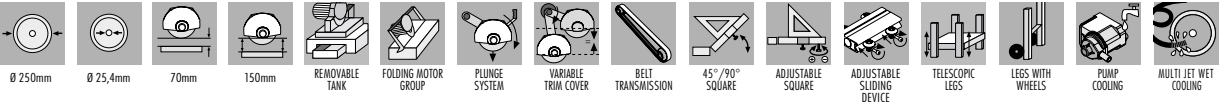

- For cutting granite, marble, porcelain, single and double fired, bricks, cement, etc...
- Maximum length of cut 105 cm (41 3/8").
- Maximum thickness of cut: 80 mm (3 1/8") in single pass; 150 mm (6") in double pass.
- Maximum blade diameter Ø 250 mm (10"); smallest blade diameter Ø 230 mm (9").
- Adjustable cutting depth.
- Tilting motor assembly for bevel cuts from 0° to 45°.
- Belt driven system optimizes motor torque and cutting capacity.
Gear ratio of motor to disc 1,4 ÷ 1. Drive belt type poly V.
- Cast and extruded aluminum framework.

- Easy-to-remove polypropylene tank for easy cleaning. Capacity: 38 lt (10 Gal).
- Heavy duty water pump and (2) jet nozzles (front or rear mounted) provide superior blade cooling.
- Sliding motor assembly with cast aluminum housing provided with 4 re-adjustable pulleys (double bearings). Extruded aluminum rail.
- Re-adjustable square for long lasting precision.
- Telescopic legs provided with double safety device to prevent collapsing.
- Floating blade guard remains in contact with tile to provide extra safety during operation.
- Pivoting blade guard remains parallel with tile to ensure maximum cutting depth.
- Equipped with: diamond disc Ø 250 mm (10") for porcelain, wheels kit for easy transport, key kit, wrench, manual.

MODEL SPECIFICATIONS

Part No.								
423ADV	8024648055163	1	230 V 50Hz	Single-phase	1,5 HP / 1,1 kW	2800	250 mm	10"
423ADV 60	8024648055927	1	230 V 60Hz	Single-phase	1,5 HP / 1,1 kW	3360	250 mm	10"
423ADV US	8024648055910	1	110 V 60Hz	Single-phase	1,3 HP / 1 kW	3360	250 mm	10"
423ADV GB	8024648055903	1	115 V 50Hz	Single-phase	1,5 HP / 1,1 kW	2800	250 mm	10"

CUTTING SPECIFICATIONS AND MACHINE DIMENSIONS / WEIGHT

Model										
PIKUS 105 ADV	250 mm 10"	80 mm 3 1/8"	55 mm 2 1/8"	105 cm 41 3/8"	∞	75x75 cm 29 1/2"x29 1/2"	145x70xh 79 cm 57"x27"x h 31"	64 Kg 141 lbs	150x73xh 95cm 59"x29"x h 37"	82 Kg 181 lbs





BRIDGE AND JOB SITE SAW MACHINES



AVAILABLE BLADES

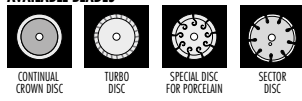

OPTIONAL



PACKAGE



TECHNICAL CHARACTERISTICS

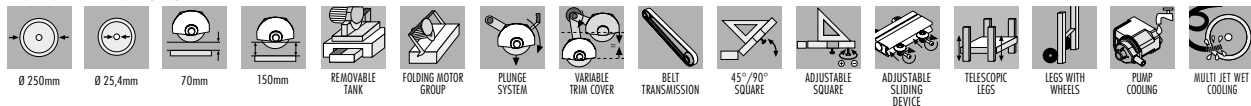

- For cutting granite, marble, porcelain, single and double fired, bricks, cement, etc...
- Maximum length of cut 130 cm (51 1/8").
- Maximum thickness of cut: 80 mm (3 1/8") in single pass; 150 mm (6") in double pass.
- Maximum blade diameter Ø 250 mm (10"); smallest blade diameter Ø 230 mm (9").
- Adjustable cutting depth.
- Tilting motor assembly for bevel cuts from 0° to 45°.
- Belt driven system optimizes motor torque and cutting capacity. Gear ratio of motor to disc 1,4 ÷ 1. Drive belt type poly V.
- Cast and extruded aluminum framework.
- Easy-to-remove polypropylene tank for easy cleaning. Capacity: 38 lt (10 Gal).
- Heavy duty water pump and (2) jet nozzles (front or rear mounted) provide superior blade cooling.
- Sliding motor assembly with cast aluminum housing provided with 4 re-adjustable pulleys (double bearings). Extruded aluminum rail.
- Re-adjustable square for long lasting precision.
- Telescopic legs provided with double safety device to prevent collapsing.
- Floating blade guard remains in contact with tile to provide extra safety during operation.
- Pivoting blade guard remains parallel with tile to ensure maximum cutting depth.
- Equipped with: diamond disc Ø 250 mm (10") for porcelain, wheels kit for easy transport, key kit, wrench, manual.

MODEL SPECIFICATIONS

Part No.	Barcode	Box	Lightning Bolt	M	Motor	Motor	Blade	Blade
425ADV	8024648055170	1	230 V 50 Hz	Single-phase	1,5 HP / 1,1 kW	2800	250 mm 10"	2000
425ADV 60	8024648055972	1	230 V 60 Hz	Single-phase	1,5 HP / 1,1 kW	3360	250 mm 10"	2400
425ADV US	8024648055965	1	110 V 60 Hz	Single-phase	1,3 HP / 1 kW	3360	250 mm 10"	2400
425ADV GB	8024648055958	1	110 V 50 Hz	Single-phase	1,5 HP / 1,1 kW	2800	250 mm 10"	2000

CUTTING SPECIFICATIONS AND MACHINE DIMENSIONS / WEIGHT

Model	Blade	Thickness	Thickness	Length	Width	Height	Weight	Dimensions	Weight
PIKUS 130 ADV	250 mm 10"	80 mm 3 1/8"	55 mm 2 1/8"	130 cm 51 1/8"	∞	90 x 90 cm 35 3/8" x 35 3/8"	78 Kg 172 lbs	170x70xh 79 cm 68"x27"x h 31"	200x80xh 110cm 78 3/4"x31 1/2"x h 43 3/8" 264.4 lbs



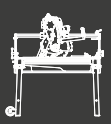

SMS 100



AVAILABLE BLADES



OPTIONAL



PACKAGE

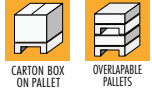

TECHNICAL CHARACTERISTICS

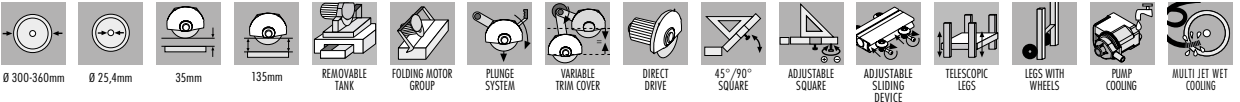

- For cutting granite, marble, porcelain, single and double fired, bricks, cement etc...
- Maximum length of cut 100 cm (39 3/8").
- Maximum depth of cut 100 mm (4") in single pass; 135 mm (5 1/8") in double pass.
- Diamond blade max Ø 360 mm (14"); min Ø 300 mm (12").
- Plunge cut and adjustable cutting depth.
- Heavy duty water pump and jet nozzles provide superior blade cooling.
- Pivoting blade guard remains parallel with tile to ensure maximum cutting depth.
- Cast and extruded aluminum framework.
- Re-adjustable square for long lasting precision.

- Easy-to-remove polypropylene tank for easy cleaning. Capacity: 38 lt (10 Gal).
- Sliding motor assembly with galvanized steel housing provided with 4 pulleys (double internal bearings each).
- Pulleys are easy to re-adjust (tighten): avoid play and confer long lasting precision of cut.
- Tilting movement (0-47°) for 45° angle cut (jolly).
- Telescopic legs provided with double safety device and wheels kit.
- Equipped with: diamond disc Ø 350 mm (14") for porcelain, wheels kit for easy transport, keys kit, user manual.
- Wide range of accessories available.

MODEL SPECIFICATIONS

Part No.	Barcode	Box	Lightning Bolt	M	Motor	Motor	Disc	Disc	
223MS100EUP	8050532006690	1	230 V 50 Hz	Single-phase	3 HP / 2,2 kW	2800	350 mm	14"	2800
223MS100V400P	8050532006461	1	400 V 50 Hz	Three-phase	3 HP / 2,2 kW	2800	350 mm	14"	2800
223MS100BRP	8050532006829	1	230 V 60 Hz	Single-phase	3 HP / 2,2 kW	3360	350 mm	14"	3360
223MS100USP	8050532006836	1	110 V 60 Hz	Single-phase	2 HP / 1,5 kW	3360	350 mm	14"	3360

CUTTING SPECIFICATIONS AND MACHINE DIMENSIONS / WEIGHT

Model	Disc	Depth	Width	Length	Wheels	Table	Motor	Weight	Box	Wheels
SMS 100	350 mm 14"	100 mm 4"	60 mm 2 3/8"	100 cm 39 3/8"	∞	70x70 cm 27 1/2" x 27 1/2"	147x70xh85 cm 58"x27 1/2"xh 33 1/2"	80 Kg 176.4 lbs	150x73xh95 cm 59"x29"x h37"	98 Kg 216.1 lbs



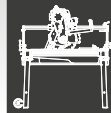

BRIDGE AND JOB SITE SAW MACHINES



AVAILABLE BLADES

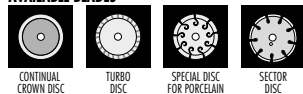

OPTIONAL

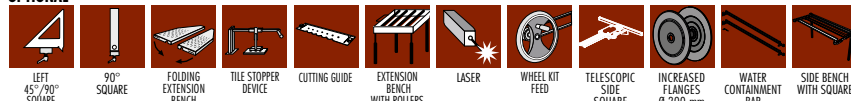

PACKAGE



TECHNICAL CHARACTERISTICS

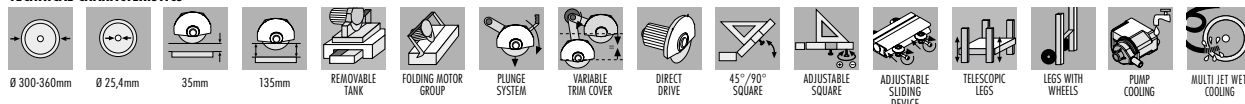

- For cutting granite, marble, porcelain, single and double fired, bricks, cement etc...
- Maximum length of cut 125 cm (49 1/4").
- Maximum depth of cut 100 mm (4") in single pass; 135 mm (5 1/8") in double pass.
- Diamond blade max Ø 360 mm (14"); min Ø 300 mm (12").
- Plunge cut and adjustable cutting depth.
- Heavy duty water pump and jet nozzles provide superior blade cooling.
- Pivoting blade guard remains parallel with tile to ensure maximum cutting depth.
- Cast and extruded aluminum framework.
- Re-adjustable square for long lasting precision.
- Easy-to-remove polypropylene tank for easy cleaning. Capacity: 38 lt (10 Gal).

- Sliding motor assembly with galvanized steel housing provided with 4 pulleys (double internal bearings each).
- Pulleys are easy to re-adjust (tighten): avoid play and confer long lasting precision of cut.
- Tilting movement (0-47°) for 45° angle cut (jolly).
- Telescopic legs provided with double safety device and wheels kit.
- Equipped with: diamond disc Ø 350 mm (14") for porcelain, wheels kit for easy transport, keys kit, user manual.
- Wide range of accessories available.

MODEL SPECIFICATIONS

Part No.	Barcode	Box	Lightning Bolt	M	Motor	Motor	Disc	Disc
223MS125EUP	8050532006706	1	230 V 50Hz	Single-phase	3 HP / 2,2 kW	2800	350 mm 14"	2800
223MS125V400P	8050532006478	1	400 V 50 Hz	Three-phase	3 HP / 2,2 kW	2800	350 mm 14"	2800
223MS125BRP	8050532006843	1	230 V 60Hz	Single-phase	3 HP / 2,2 kW	3360	350 mm 14"	3360
223MS125USP	8050532006850	1	110 V 60Hz	Single-phase	2 HP / 1,5 kW	3360	350 mm 14"	3360

CUTTING SPECIFICATIONS AND MACHINE DIMENSIONS / WEIGHT

Model	Disc	Depth	Depth	Depth	Depth	Depth	Depth	Weight	Dimensions	Weight
SMS 125	350 mm 14"	100 mm 4"	60 mm 2 3/8"	125 cm 49 1/4"	∞	88x88 cm 34 5/8" x 34 5/8"	175x70x85 cm 69"x27 1/2"x33 1/2"	84 Kg 185.2 lbs	200x80x110 cm 78 3/4"x31 1/2"x43 3/8"	125 Kg 275.6 lbs



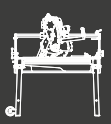

SMS 150



AVAILABLE BLADES

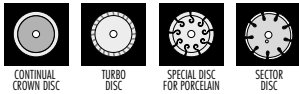

OPTIONAL

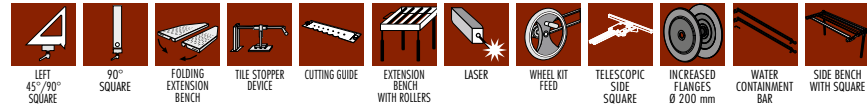

PACKAGE

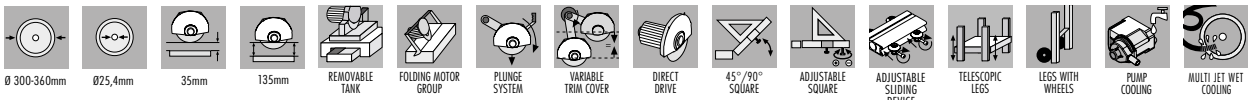

- For cutting granite, marble, porcelain, single and double fired, bricks, cement etc...
- Maximum length of cut 150 cm (59").
- Maximum depth of cut 100 mm (4") in single pass; 135 mm (5 1/8") in double pass.
- Diamond blade max Ø 360 mm (14"); min Ø 300 mm (12").
- Plunge cut and adjustable cutting depth.
- Heavy duty water pump and jet nozzles provide superior blade cooling.
- Pivoting blade guard remains parallel with tile to ensure maximum cutting depth.
- Cast and extruded aluminum framework.
- Re-adjustable square for long lasting precision.
- Easy-to-remove polypropylene tank for easy cleaning. Capacity: 38 lt (10 Gal).

- Sliding motor assembly with galvanized steel housing provided with 4 pulleys (double internal bearings each).
- Pulleys are easy to re-adjust (tighten): avoid play and confer long lasting precision of cut.
- Tilting movement (0-47°) for 45° angle cut (jolly).
- Telescopic legs provided with double safety device and wheels kit.
- Equipped with: diamond disc Ø 350 mm (14") for porcelain tiles, wheels kit for easy transport, keys kit, user manual.
- Wide range of accessories available.

MODEL SPECIFICATIONS

Part No.	Barcode	Box	Lightning Bolt	M	Motor	Motor	Blade	Blade
223MS150EUP	8050532002760	1	230 V 50 Hz	Single-phase	3 HP / 2,2 kW	2800	350 mm 14"	2800
223MS150V400	8050532005471	1	400 V 50 Hz	Three-phase	3 HP / 2,2 kW	2800	350 mm 14"	2800
223MS150BRP	8050532002753	1	230 V 60 Hz	Single-phase	3 HP / 2,2 kW	3360	350 mm 14"	3360
223MS150USP	8050532002777	1	110 V 60 Hz	Single-phase	2 HP / 1,5 kW	3360	350 mm 14"	3360

CUTTING SPECIFICATIONS AND MACHINE DIMENSIONS / WEIGHT

Model	Blade	Depth	Width	Length	Wheels	Table	Motor	Weight	Case	Weight
SMS 150	350 mm 14"	100 mm 4"	60 mm 2 3/8"	150 cm 59"	∞	106x106 cm 41 5/8" x 41 5/8"	200x70xh85 cm 78 3/4" x 27 1/2" x h 33 1/2"	89 Kg 196.2 lbs	200x80xh110 cm 78 3/4" x 31 1/2" x h 43 3/8"	130 Kg 286.6 lbs



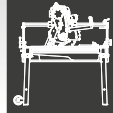

AVAILABLE BLADES

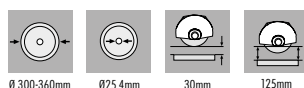
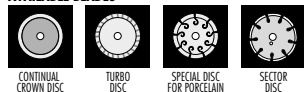

OPTIONAL

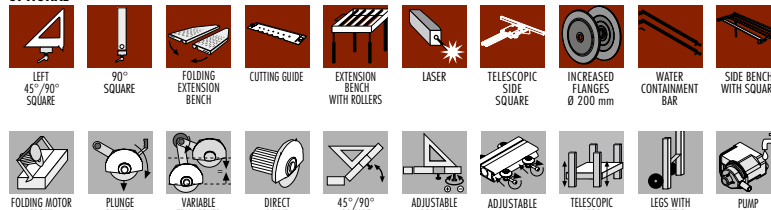

PACKAGE



- For cutting granite, marble, porcelain, single and double fired, bricks, cement etc...
- Maximum length of cut 220 cm (86 2/8").
- Maximum depth of cut 90 mm (3 1/2") in single pass; 125 mm (4") in double pass.
- Diamond blade max Ø 360 mm (14"); min Ø 300 mm (12").
- Plunge cut and adjustable cutting depth.
- Heavy duty water pump and jet nozzles provide superior blade cooling.
- Water jet near to the cutting point for an optimal cooling.
- Pivoting blade guard remains parallel with tile to ensure maximum cutting depth.
- Cast and extruded aluminum framework.
- Re-adjustable square for long lasting precision.
- Easy-to-remove polypropylene tank for easy cleaning. Capacity: 38 lt (10 Gal).

- Sliding motor assembly with galvanized steel housing provided with 4 pulleys (double internal bearings each).
- Pulleys are easy to re-adjust (tighten): avoid play and confer long lasting precision of cut.
- Tilting movement (0-47°) for 45° angle cut (jolly).
- Equipped with the motor feed system with wheel kit.
- Telescopic legs provided with double safety device and wheels kit.
- Equipped with: diamond disc Ø 350 mm (14") for porcelain tiles, wheel kit feed, wheels kit for easy transport, keys kit, user manual.
- Wide range of accessories available.

MODEL SPECIFICATIONS

Part No.	Barcode	Box	Lightning Bolt	M	Motor	Motor	Wheel	Wheel
223MS200EU	8024648096289	1	230 V 50 Hz	Single-phase	3 HP / 2,2 kW	2800	350 mm 14"	2800
223MS200V400	8050532005518	1	400 V 50 Hz	Three-phase	3 HP / 2,2 kW	2800	350 mm 14"	2800
223MS200BR	8024648096265	1	230 V 60 Hz	Single-phase	3 HP / 2,2 kW	3360	350 mm 14"	3360
223MS200US	8024648096302	1	110 V 60 Hz	Single-phase	2 HP / 1,5 kW	3360	350 mm 14"	3360

CUTTING SPECIFICATIONS AND MACHINE DIMENSIONS / WEIGHT

Model	Blade	Depth	Width	Length	Extension	Table	Motor	Weight	Dimensions	Weight
SMS 220	350 mm 14"	90 mm 3 1/2"	50 mm 2"	220 cm 86 2/8"	∞	155x155 cm 61"x 61"	270x85xh 85 cm 106"x33 1/2"xh 33 1/2"	120 Kg 264.6 lbs	275x85xh 92 cm 108 1/4"x33 1/2"xh 36 1/5"	208 Kg 458.6 lbs



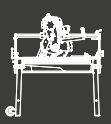

SMS 260



AVAILABLE BLADES

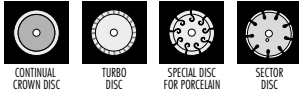

OPTIONAL

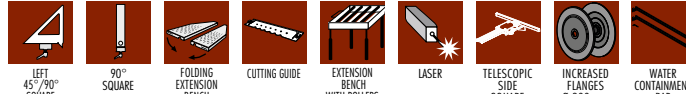

PACKAGE

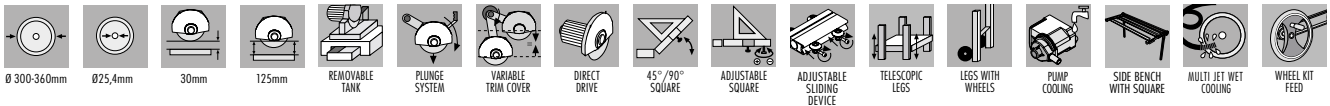

- For cutting granite, marble, porcelain, single and double fired, bricks, cement etc...
- Maximum length of cut 260 cm (102 1/8").
- Maximum depth of cut: 90 mm (3 1/2") in single pass; 125 mm (5") in double pass.
- Diamond blade max Ø 360 mm (14"); min Ø 300 mm (12").
- Plunge cut and adjustable cutting depth.
- Heavy duty water pump and jet nozzles provide superior blade cooling.
- Water jet near to the cutting point for an optimal cooling.
- Pivoting blade guard remains parallel with tile to ensure maximum cutting depth.
- Cast and extruded aluminum framework.
- Re-adjustable square for long lasting precision.
- Easy-to-remove polypropylene tank for easy cleaning. Capacity: 38 lt (10 Gal).

- Sliding motor assembly with galvanized steel housing provided with 4 pulleys (double internal bearings each).
- Pulleys are easy to re-adjust (tighten): avoid play and confer long lasting precision of cut.
- Equipped with the motor feed system with wheel kit.
- Equipped with side bench with adjustable square, which allow to maintain a perfect parallelism between the tile and the cutting line.
- Telescopic legs provided with double safety device and wheels kit.
- Equipped with: Ø 350 mm (14") diamond disc for porcelain tiles, wheel kit feed, side bench with adjustable square, wheels kit for easy transport, keys kit, user manual.
- Wide range of accessories available.

MODEL SPECIFICATIONS

Part No.	Barcode	Box	Lightning Bolt	M	Motor	Motor	Disc	Disc
223MS260EU	8050532001756	1	230 V 50 Hz	Single-phase	3 HP / 2,2 kW	2800	350 mm 14"	2800
223MS260V400	8050532005532	1	400 V 50 Hz	Three-phase	3 HP / 2,2 kW	2800	350 mm 14"	2800
223MS260BR	8050532001589	1	230 V 60 Hz	Single-phase	3 HP / 2,2 kW	3360	350 mm 14"	3360
223MS260US	8050532001640	1	110 V 60 Hz	Single-phase	2 HP / 1,5 kW	3360	350 mm 14"	3360

CUTTING SPECIFICATIONS AND MACHINE DIMENSIONS / WEIGHT

Model	Disc	Height	Length	Width	Depth	Motor	Weight	Dimensions	Weight
SMS 260	350 mm 14"	90 mm 3 1/2"	260 cm 102 1/8"	∞	181x181 cm 71"x71"	310x75xh 135 cm 122"x29 1/2"xh 53"	199 Kg 438.7 lbs	315x95xh 170 cm 124"x37 1/2"xh 67"	279 Kg 615.1 lbs





BRIDGE AND JOB SITE SAW MACHINES

AVAILABLE BLADES

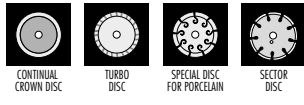

OPTIONAL

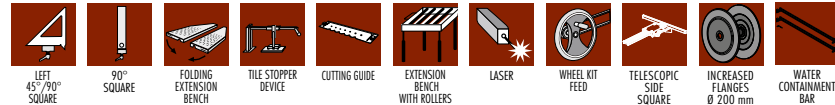

PACKAGE

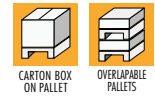

TECHNICAL CHARACTERISTICS

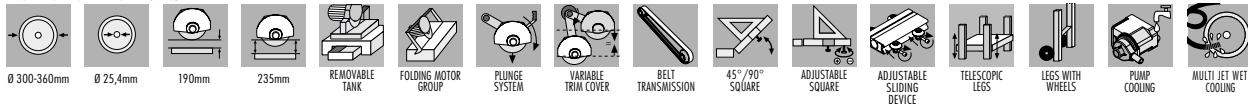

- For cutting granite, marble, porcelain, single and double fired, bricks, cement, etc...
- Maximum length of cut 85 cm (33 1/2").
- Maximum thickness of cut: 110 mm (4 1/8") in single pass; 235 mm (9 1/4") in double pass.
- Maximum blade diameter Ø 360 mm (14"); smallest blade diameter Ø 300 mm (12").
- Adjustable cutting depth.
- Tilting motor assembly for bevel cuts from 0° to 45°.
- Belt driven system optimizes motor torque and cutting capacity. Gear ratio of motor to disc 1,4 ÷ 1. Drive belt type poly V.
- Cast and extruded aluminum framework.
- Easy-to-remove polypropylene tank for easy cleaning. Capacity: 38 lt (10 Gal).

- Heavy duty water pump and (2) jet nozzles provide superior blade cooling.
- Sliding motor assembly with cast aluminum housing provided with 4 re-adjustable pulleys (double bearings). Extruded aluminum rail.
- Re-adjustable square for long lasting precision.
- Telescopic legs provided with safety device to prevent collapsing.
- Pivoting blade guard remains parallel with tile to ensure maximum cutting depth.
- Floating blade guard remains in contact with tile to provide extra safety during operation.
- Equipped with: diamond disc Ø 350 mm (14") for porcelain tiles, wheels kit for easy transport, pressure device to hold tile, key kit, wrench, manual.

MODEL SPECIFICATIONS

Part No.	Barcode	Box	Lightning Bolt	M	Motor	Motor	Disc	Disc
42085A P	8050532006744	1	230 V 50 Hz	Single-phase	3 HP / 2,2 kW	2800	350 mm 14"	2000
42085A 400VP	8050532006898	1	400 V 50 Hz	Three-phase	3 HP / 2,2 kW	2800	350 mm 14"	2000
42085A 60HZP	8050532006904	1	230 V 60 Hz	Single-phase	3 HP / 2,2 kW	3360	350 mm 14"	2400
42085A USP	8050532006874	1	110 V 60 Hz	Single-phase	2,2 HP / 1,65 kW	3360	350 mm 14"	2400
42085A GBP	8050532006867	1	110 V 50 Hz	Single-phase	2,2 HP / 1,65 kW	2800	350 mm 14"	2000

CUTTING SPECIFICATIONS AND MACHINE DIMENSIONS / WEIGHT

Model	Disc	Thickness	Thickness	Length	Length	Table	Table	Weight	Weight	Weight
ZOE 85 ADV	Ø 350 mm 14"	110 mm 4 1/8"	80 mm 3 1/8"	85 cm 33 1/2"	∞	60x60 cm 23 5/8"x23 5/8"	125x70xh 95 cm 50"x27"x h 37"	80 Kg 176.4 lbs	150x73xh 110cm 59"x29"x h 43"	98 Kg 216.1 lbs

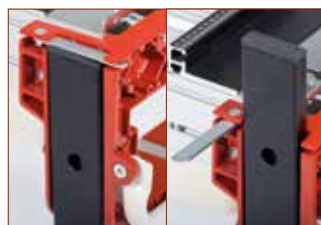

ZOE 105 ADVANCED

BRIDGE AND JOB SITE SAW MACHINES



AVAILABLE BLADES

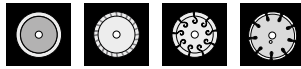

CONTINUAL CROWN DISC TURBO DISC SPECIAL DISC FOR PORCELAIN SECTOR DISC

OPTIONAL



LEFT 45°/90° SQUARE 90° SQUARE FOLDING EXTENSION BENCH TILE STOPPER DEVICE CUTTING GUIDE EXTENSION BENCH WITH ROLLERS LASER WHEEL KIT FEED TELESCOPIC SIDE SQUARE INCREASED FLANGES Ø 200 mm WATER CONTAINMENT BAR

PACKAGE



CARTON BOX ON PALLET OVERLAPABLE PALLETS

TECHNICAL CHARACTERISTICS



Ø 300-360mm Ø 25,4mm 190mm 235mm REMOVABLE TANK FOLDING MOTOR GROUP PLUNGE SYSTEM VARIABLE TRIM COVER BELT TRANSMISSION 45°/90° SQUARE ADJUSTABLE SQUARE ADJUSTABLE SLIDING DEVICE TELESCOPIC LEGS LEGS WITH WHEELS PUMP COOLING MULTI JET WET COOLING

- For cutting granite, marble, porcelain, single and double fired, bricks, cement, etc...
- Maximum length of cut 105 cm (41 3/8").
- Maximum thickness of cut: 110 mm (4 1/8") in single pass; 235 mm (9 1/4") in double pass.
- Maximum blade diameter Ø 360 mm (14"); smallest blade diameter Ø 300 mm (12").
- Adjustable cutting depth.
- Tilting motor assembly for bevel cuts from 0° to 45°.
- Belt driven system optimizes motor torque and cutting capacity. Gear ratio of motor to disc 1,4 ÷ 1. Drive belt type poly V.
- Cast and extruded aluminum framework.
- Easy-to-remove polypropylene tank for easy cleaning. Capacity: 38 lt (10 Gal).

- Heavy duty water pump and (2) jet nozzles provide superior blade cooling.
- Sliding motor assembly with cast aluminum housing provided with 4 re-adjustable pulleys (double bearings). Extruded aluminum rail.
- Re-adjustable square for long lasting precision.
- Telescopic legs provided with safety device to prevent collapsing.
- Pivoting blade guard remains parallel with tile to ensure maximum cutting depth.
- Floating blade guard remains in contact with tile to provide extra safety during operation.
- Equipped with: diamond disc Ø 350 mm (14") for porcelain tiles, wheels kit for easy transport, pressure device to hold tile, key kit, wrench, manual.

MODEL SPECIFICATIONS

Part No.	Barcode	Box	Lightning Bolt	M	Motor	Motor	Blade	Blade	Blade
420105A P	8050532006508	1	230 V 50 Hz	Single-phase	3 HP/2,2 kW	2800	350 mm	14"	2000
420105A 400VP	8050532006539	1	400 V 50 Hz	Three-phase	3 HP/2,2 kW	2800	350 mm	14"	2000
420105A 60HVP	8050532006546	1	230 V 60 Hz	Single-phase	3 HP/2,2 kW	3360	350 mm	14"	2400
420105A USP	8050532006515	1	110 V 60 Hz	Single-phase	2,2 HP/1,65 kW	3360	350 mm	14"	2400
420105A GBP	8050532006492	1	110 V 50 Hz	Single-phase	2,2 HP/1,65 kW	2800	350 mm	14"	2000

CUTTING SPECIFICATIONS AND MACHINE DIMENSIONS / WEIGHT

Model	Blade	Height	Thickness	Length	Width	Table	Table	Weight	Box	Weight
ZOE 105 ADV	Ø 350 mm 14"	110 mm 4 1/3"	80 mm 3 1/8"	105 cm 41 3/8"	∞	75 x 75 cm 29 1/2" x 29 1/2"	145x70xh 95 cm 57"x27"x h 37"	84 Kg 185.2 lbs	150x73xh 110cm 59"x29"x h 43"	102 Kg 224.9 lbs





BRIDGE AND JOB SITE SAW MACHINES

AVAILABLE BLADES

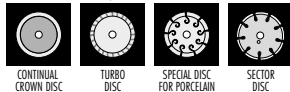

ACCESSORIES

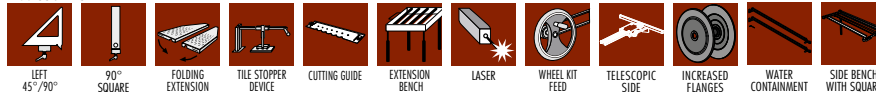

PACKAGE

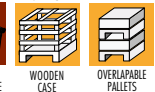

TECHNICAL CHARACTERISTICS

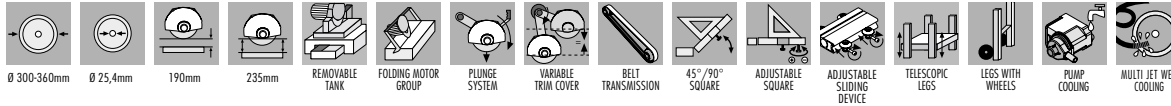

- For cutting granite, marble, porcelain, single and double fired, bricks, cement, etc...
- Maximum length of cut 130 cm (51 1/8").
- Maximum thickness of cut: 110 mm (4 1/8") in single pass; 235 mm (9 1/4") in double pass.
- Maximum blade diameter Ø 360 mm (14"); smallest blade diameter Ø 300 mm (12").
- Adjustable cutting depth.
- Tilting motor assembly for bevel cuts from 0° to 45°.
- Belt driven system optimizes motor torque and cutting capacity.
Gear ratio of motor to disc 1,4 ÷ 1. Drive belt type poly V.
- Cast and extruded aluminum framework.
- Easy-to-remove polypropylene tank for easy cleaning. Capacity: 38 lt (10 Gal).

- Heavy duty water pump and (2) jet nozzles provide superior blade cooling.
- Sliding motor assembly with cast aluminum housing provided with 4 re-adjustable pulleys (double bearings). Extruded aluminum rail.
- Re-adjustable square for long lasting precision.
- Telescopic legs provided with safety device to prevent collapsing.
- Pivoting blade guard remains parallel with tile to ensure maximum cutting depth.
- Floating blade guard remains in contact with tile to provide extra safety during operation.
- Equipped with: diamond disc Ø 350 mm (14") for porcelain tiles, wheels kit for easy transport, pressure device to hold tile, key kit, wrench, manual.

MODEL SPECIFICATIONS

Part No.	Barcode	Box	Lightning Bolt	M	Motor	Motor	Blade	Blade	
420130A P	8050532006560	1	230 V 50 Hz	Single-phase	3 HP / 2,2 kW	2800	350 mm	14"	2000
420130A 400VP	8050532006584	1	400 V 50 Hz	Three-phase	3 HP / 2,2 kW	2800	350 mm	14"	2000
420130A 60H2P	8050532006591	1	230 V 60 Hz	Single-phase	3 HP / 2,2 kW	3360	350 mm	14"	2400
420130A USP	8024648056900	1	110 V 60 Hz	Single-phase	2,2 HP / 1,65 kW	3360	350 mm	14"	2400
420130A GBP	8050532006553	1	110 V 50 Hz	Single-phase	2,2 HP / 1,65 kW	2800	350 mm	14"	2000

CUTTING SPECIFICATIONS AND MACHINE DIMENSIONS/WEIGHT

Model	Blade	Table	Table	Table	Table	Table	Table	Weight	Weight	Weight
ZOE 130 ADV	Ø 350 mm 14"	110 mm 4 1/8"	80 mm 3 1/8"	130 cm 51 1/8"	∞	90x90 cm 35 3/8"x35 3/8"	170x70xh 95 cm 67"x27"x h 37"	98 Kg 216 lbs	200x80xh 110cm 78 3/4"x31 1/2"x h 43"	139 Kg 306.4 lbs



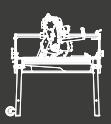

BRIDGE AND JOB SITE SAW MACHINES

ZOE 150 ADVANCED



AVAILABLE BLADES

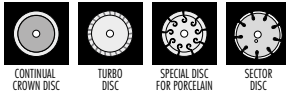

ACCESSORIES

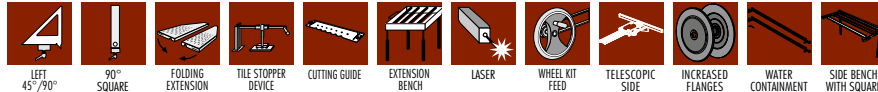

PACKAGE



TECHNICAL CHARACTERISTICS

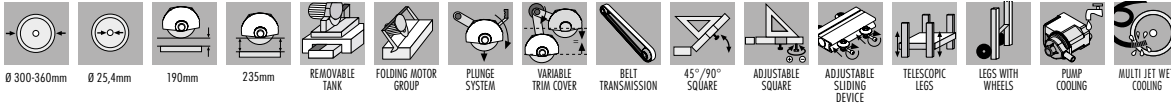

- For cutting granite, marble, porcelain, single and double fired, bricks, cement, etc. . .
- Maximum length of cut: 155 cm (61").
- Maximum thickness of cut: 110 mm (4 1/8") in single pass; 235 mm (9 1/4") in double pass.
- Maximum blade diameter Ø 360 mm (14"); smallest blade diameter Ø 300 mm (12").
- Adjustable cutting depth.
- Tilting motor assembly for bevel cuts from 0° to 45°.
- Belt driven system optimizes motor torque and cutting capacity.
Gear ratio of motor to disc 1,4 ÷ 1. Drive belt type poly V.
- Cast and extruded aluminum framework.

- Easy-to-remove polypropylene tank for easy cleaning. Capacity: 38 lt (10 Gal).
- Heavy duty water pump and (2) jet nozzles provide superior blade cooling.
- Sliding motor assembly with cast aluminum housing provided with 4 re-adjustable pulleys (double bearings). Extruded aluminum rail.
- Re-adjustable square for long lasting precision.
- Telescopic legs provided with safety device to prevent collapsing.
- Pivoting blade guard remains parallel to tile to ensure maximum cutting depth.
- Floating blade guard remains in contact with tile to provide extra safety during operation.
- Equipped with: diamond disc Ø 350 mm (14") for porcelain tiles, wheels kit for easy transport, pressure device to hold tile, key kit, wrench, manual.

MODEL SPECIFICATIONS

Part No.	Barcode	Box	Lightning Bolt	M	Motor	Motor	Blade	Blade
420150A AP	8050532002692	1	230 V 50 Hz	Single-phase	3 HP / 2,2 kW	2800	350 mm 14"	2000
420150A 400P	8050532002739	1	400 V 50 Hz	Three-phase	3 HP / 2,2 kW	2800	350 mm 14"	2000
420150A 60HP	8050532002746	1	230 V 60 Hz	Single-phase	3 HP / 2,2 kW	3360	350 mm 14"	2400
420150A USP	8050532002715	1	110 V 60 Hz	Single-phase	2,2 HP / 1,65 kW	3360	350 mm 14"	2400
420150A GBP	8050532002760	1	110 V 50 Hz	Single-phase	2,2 HP / 1,65 kW	2800	350 mm 14"	2000

CUTTING SPECIFICATIONS AND MACHINE DIMENSIONS/WEIGHT

Model	Blade	Thickness	Depth	Length	Width	Height	Weight	Dimensions	Weight	
ZOE 150 ADV	Ø 350 mm 14"	110 mm 4 1/8"	80 mm 3 1/8"	155 cm 61"	∞	109x109 cm 42 7/8" x 42 7/8"	200x70x h95 cm 78 3/4"x27"xh37"	106 Kg 233.7 lbs	200x80x h110 cm 78 3/4"x31 1/2"xh43"	147 Kg 324 lbs



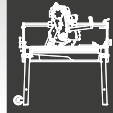

AVAILABLE BLADES

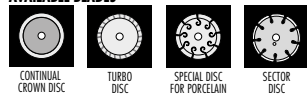

ACCESSORIES



PACKAGE

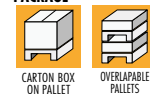

TECHNICAL CHARACTERISTICS

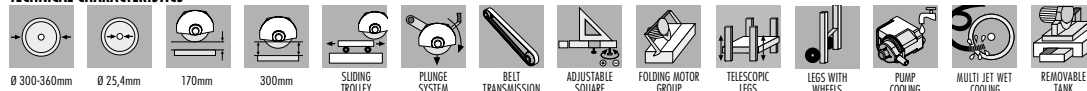

- For cutting ceramic tiles, porcelain, marble, granite, bricks, cement, etc...straight and 45° bevel (Jolly).
- Maximum length of cut: 80 cm (31 1/2").
- Maximum width of cut: 60 cm (23 5/8").
- Maximum thickness of cut single pass: 120 mm (4 3/4"); double pass: 170 mm (6 5/8").
- Aluminum framework.
- Adjust depth of cut manually.
- Tilting motor assembly 0-45°.
- Maximum blade: Ø 360 mm (14"); minimum blade: Ø 300 mm (12").
- Belt driven system optimizes motor torque and cutting capacity.

- Gear ratio of motor to disc 1,4 ÷ 1. Drive belt type poly V.
- Heavy duty pump and jet nozzles provide superior blade cooling.
- Removable polypropylene tank for easy cleaning. Capacity: 38 lt (10 Gal).
- Trolley is provided with anti-overturning device and locking system for safe and easy transport.
- Trolley equipped with 8 adjustable pulleys (double bearings).
- Steel made replaceable trolley guides.
- Telescopic legs provided with double safety device.
- Equipped with: segmented diamond disc Ø 360 mm (14"), wheels kit for easy transport, key kit, wrench, manual.

MODEL SPECIFICATIONS

Part No.	Barcode	Box	Lightning Bolt	M	Motor	Motor	Disc	Disc
218A	8024648019202	1	230 V 50 Hz	Single-phase	3 HP / 2,2 kW	2800	360 mm 14"	2000
218A 60HZ	8024648019240	1	230 V 60 Hz	Single-phase	3 HP / 2,2 kW	3360	360 mm 14"	2400
218A USA	8024648019226	1	110 V 60 Hz	Single-phase	3 HP / 2,2 kW	3360	360 mm 14"	2400
218A GB	8024648019219	1	115 V 50 Hz	Single-phase	3 HP / 2,2 kW	2800	360 mm 14"	2000

CUTTING SPECIFICATIONS AND MACHINE DIMENSIONS/WEIGHT

Model	Blade Diameter	Blade Thickness	Blade Width	Blade Length	Blade Width	Blade Length	Blade Length	Weight	Dimensions	Weight
SA80	360 mm 14"	120 mm 4 3/4"	65 mm 2 9/16"	80 cm 31 1/2"	60 cm 23 5/8"	50x50 cm 20"x20"	110x75xh 80 cm 43 3/8"x30"xh 31 1/2"	77 Kg 169.8 lbs	120x80xh 100 cm 47 1/4"x31 1/2"xh 39 3/8"	96 Kg 211.6 lbs

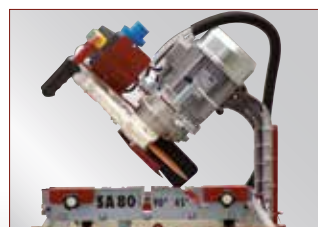

SA09

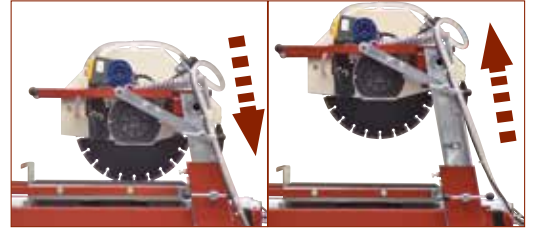

AVAILABLE BLADES

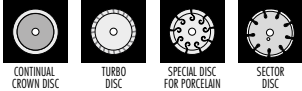

CONTINUAL CROWN DISC TURBO DISC SPECIAL DISC FOR PORCELAIN SECTOR DISC

ACCESSORIES

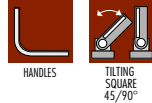

HANDLES TILTING SQUARE 45/90°

PACKAGE

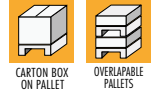

CARTON BOX ON PALLET OVERLAPABLE PALLETS

TECHNICAL CHARACTERISTICS

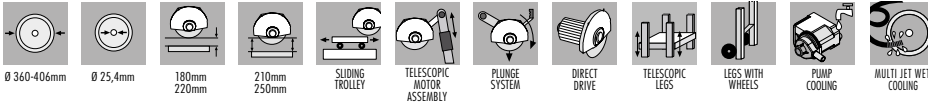

Ø 360-406mm Ø 25,4mm 180mm / 220mm 210mm / 250mm SLIDING TROLLEY TELESCOPIC MOTOR ASSEMBLY PLUNGE SYSTEM DIRECT DRIVE TELESCOPIC LEGS LEGS WITH WHEELS PUMP COOLING MULTI JET WET COOLING

- For cutting high thickness bricks, stones, concrete, etc... Suitable also for cutting ceramic tiles, porcelain, etc... straight and 45° bevel/jolly (accessory required for 45° bevel/jolly).
- Maximum thickness of cut in single pass: 125 mm (5") with disc Ø 406 mm (16"); 105 mm (4 1/8") with disc Ø 360 mm (14").
- Maximum thickness of cut in double pass: 250 mm (10") with disc Ø 406 mm (16"); 210 mm (8 1/4") with disc Ø 360 mm (14").
- Maximum length of cut: material with thickness up to 7 cm (2 3/4"); 80 cm (31 1/2"); material with thickness 25 cm (10"): 55 cm (22").
- Adjustable depth of cut. Removable motor assembly.
- Innovative telescopic motor assembly for depth of cut maximization.
- Disc diameter: max Ø 406 mm (16"); min Ø 360 mm (14").
- Trolley is provided with anti-overturning device and locking system for safe and easy transport.
- Trolley equipped with 8 adjustable pulleys (double bearings).
- Steel made replaceable trolley guides.
- Heavy duty pump provides superior blade cooling.
- Telescopic legs provided with safety device and wheels kit.
- Equipped with: segmented diamond disc Ø 360 mm (14"), wheels kit for easy transport, key kit, wrench, manual. Handles not included.

MODEL SPECIFICATIONS

Part No.	Barcode	Box	Lightning Bolt	M	Motor	Motor	Disc	Disc	
203SA09	8024648064561	1	230 V 50 Hz	Single-phase	3 HP / 2,2 kW	2800	360 mm	14"	2800
203SA09 60HZ	8024648066510	1	230 V 60 Hz	Single-phase	3 HP / 2,2 kW	3360	360 mm	14"	3360
203SA09 US	8024648066503	1	110 V 60 Hz	Single-phase	2 HP / 1,5 kW	3360	360 mm	14"	3360

CUTTING SPECIFICATIONS AND MACHINE DIMENSIONS/WEIGHT

Model	Disc	UNICA PASSATA	DOPPIA PASSATA	Block	Block	Block	Block	Block	Block	Weight	Box	Weight
SA09	360 mm 14" 406 mm 16"	105 mm 4 1/8" 125 mm 5"	210 mm 8 1/4" 250 mm 10"	50 mm 2" 70 mm 2 3/4"	80 cm 31 1/2"	60 cm 23 5/8"	50x50 cm 20"x20"	120x70x75 cm 47"x27 1/2"xh 29 1/2"	80 Kg 176.4 lbs	120x80xh 100 cm 47"x31 1/2"xh 39 3/8"	99 Kg 218.3 lbs	



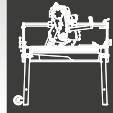

AVAILABLE BLADES



SECTOR DISC

ACCESSORIES



LASER



TILTING SQUARE

45/90°

PACKAGE



WOODEN CASE



OVERLAPABLE PALLETS

TECHNICAL CHARACTERISTICS



Ø 500-630mm



Ø 30mm



165mm / 110mm



250mm



SLIDING TROLLEY



PLUNGE SYSTEM



FOLDING MOTOR GROUP



BELT TRANSMISSION



TELESCOPIC LEGS



ARRANGED FOR LIFTING EQUIPMENT



LEGS WITH WHEELS



PUMP COOLING



MULTI JET WET COOLING



REMOVABLE TANK

- For cutting high thickness bricks, stones, concrete, etc. . .
- Maximum length of cut 65 cm (25 3/8") for materials of thickness up to 16,5 cm (6 1/2").
- Maximum length of cut 40 cm (15 3/4") for materials of thickness up to 20 cm (7 7/8").
- Maximum depth of cut in single pass: 25 cm (9 7/8") with Ø 600 mm (23 5/8") disc; 20 cm (7 7/8") with Ø 500 mm (20") disc.
- Maximum depth of cut in double pass: 25 cm (9 7/8")
- Maximum length of cut with Ø 600 mm (23 3/8") blade: 70 cm (27 1/2") for materials up to 14 cm (5 1/2") thickness; 45 cm (17 11/16") for materials up to 25 cm (9 7/8") thickness.
- Maximum length of cut with Ø 500 mm (20") blade: 70 cm (27 1/2")
- Maximum blade: Ø 600 mm (23 3/8"); minimum blade: Ø 400 mm (15 3/4").
- Belt driven system optimizes motor torque and cutting capacity. Gear ratio of motor to disc 1,1 ÷ 1. Drive belt type poly V.
- Double floating blade guards provide extra safety during operation.
- Heavy duty external pump and jet nozzles provide superior blade cooling.
- Removable polypropylene tank for easy cleaning. Capacity: 56 lt (14.8 Gal).
- Trolley is provided with anti-overturning device and locking system for safe and easy transport.
- Trolley equipped with 6 adjustable pulleys (double bearings).
- Steel made replaceable trolley guides.
- Telescopic legs provided with safety device.
- Provided with hook housing for lifting equipment.
- Equipped with: key kit, wrench, user and maintenance manual.

MODEL SPECIFICATIONS

Part No.								
218AS 230SD	8024648017659	1	230 V / 50 Hz	Single-phase	3,3 HP / 2,4 kW	1400	-	1260
218AS 400SDN	8024648082466	1	400 V / 50 Hz	Three-phase	4,5 HP / 3,3 kW	1400	-	1260

CUTTING SPECIFICATIONS AND MACHINE DIMENSIONS/WEIGHT

Model												
SHERPA	630 mm	25 cm	13 cm	25 cm	10"	45 cm	17 11/16"	49x49 cm 19"x19"	145x75xh 110 cm 57"x30"xh 43"	137 Kg 302 lbs	170x90xh 140 cm 67"x35 1/2"xh 55"	179 Kg 394.6 lbs
	500 mm	18 cm	11 cm	18 cm	7"	70 cm	27 1/2"					
	20"	7"	4 3/8"	18 cm	7"	70 cm	27 1/2"					



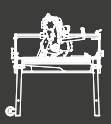

BRIDGE AND JOB SITE SAW MACHINES

ACCESSORIES FOR BRIDGE SAW MACHINES

MADE IN ITALY

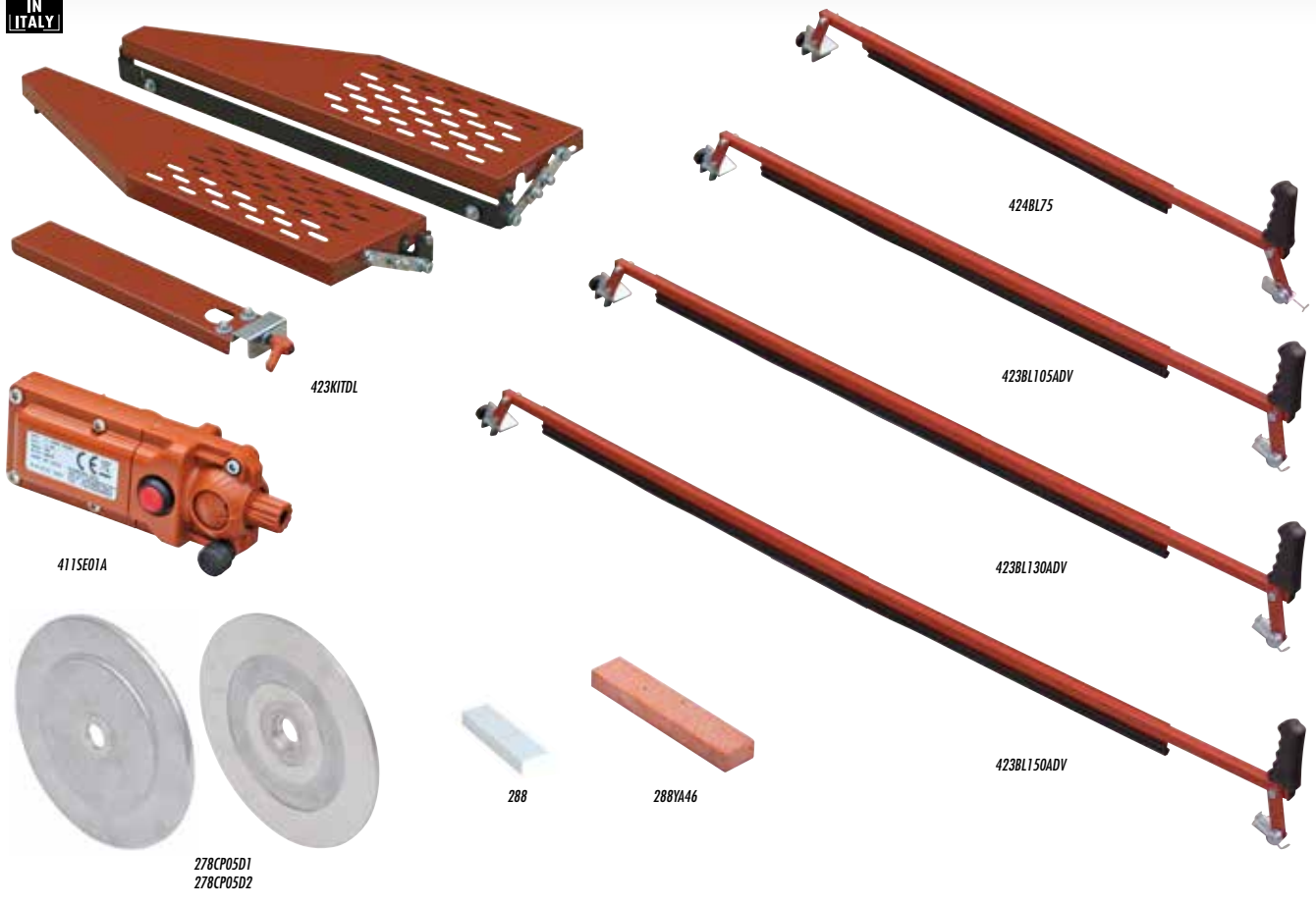

Part No.			Description			
423KITDL	8024648010476	1	Optional kit: folding extension tables and 90° left square	71x22xh 10 cm	28" x8 5/8" xh 4"	5 Kg 11 lbs
424BL75	8024648006622	1	Tile holder for Pikus 75	89x24xh 20 cm	35"x9 1/2" xh 7 7/8"	1,8 Kg 4 lbs
423BL105ADV	8024648056757	1	Tile holder for Pikus 105 ADV, SMS 100, Zoe 105 ADV	117x24xh 20 cm	46"x9 1/2" xh 7 7/8"	2,6 Kg 5.7 lbs
423BL130ADV	8024648066459	1	Tile holder for Pikus 130 ADV, SMS 125, Zoe 130 ADV	153x24xh 20 cm	60"x9 1/2" xh 7 7/8"	3 Kg 6.6 lbs
423BL150ADV	8024648071187	1	Tile holder for SMS150 e Zoe 150 ADV	178x24xh 20 cm	70"x9 1/2" xh 7 7/8"	3,5 Kg 7.7 lbs
411SE01A	8024648065254	1	Laser without stirrup	-	-	- -
411SE A1	8024648070906	1	Laser with stirrup for ZOE Adv	-	-	- -
411SE A2	8024648070913	1	Laser with stirrup for Pikus Adv	-	-	- -
411SE A4	8024648070937	1	Laser with stirrup for SMS100, 125 and 150	-	-	- -
411SE A9	8024648005663	1	Laser with stirrup for SMS220 and SMS260	-	-	- -
288	8024648004178	1	Dressing stone 30 x100xh 15 mm (1 3/16" x 4" xh 5/8")	-	-	- -
288YA46	8024648079619	1	Dressing stone 45x230xh 25 mm (1 3/4" x9 1/16" xh 1")	-	-	- -
278CP05D1	8024648079060	2	Flanges (pair) Ø 200 mm (8") for Zoe ADV	-	-	- -
278CP05D2	8024648079077	2	Flanges (pair) Ø 200 mm (8") for SMS and Mistral	-	-	- -

Part No.	EXPLOIT			BOLT			MISTRAL			PIKUS				PIKUS ADV				SMS				ZOE ADV				SA	SA	SHERPA
	70	90	120	90	120	150	90	120	150	75	85	105	130	100	125	150	220	260	85	105	130	150	80	09				
423KITDL	-	-	-	-	-	-	-	-	-	-	•	•	•	•	•	•	•	•	•	•	•	•	-	-	-			
424BL75	-	-	-	-	-	-	-	-	-	-	•	•	•	•	•	•	•	•	•	•	•	•	-	-	-			
423BL105ADV	-	-	-	-	-	-	-	-	-	-	-	•	•	•	•	•	•	•	•	•	•	•	-	-	-			
423BL130ADV	-	-	-	-	-	-	-	-	-	-	-	-	•	•	•	•	•	•	•	•	•	•	-	-	-			
423BL150ADV	-	-	-	-	-	-	-	-	-	-	-	-	-	•	•	•	•	•	•	•	•	•	-	-	-			
411SE01A	-	-	-	-	-	-	-	-	-	-	-	-	-	-	-	-	-	-	-	-	-	-	-	-	-			
411SE A1	-	-	-	-	-	-	-	-	-	-	-	-	-	-	-	-	-	-	-	•	•	•	•	-	-			
411SE A2	-	-	-	-	-	-	-	-	-	-	-	-	-	-	-	-	-	-	-	•	•	•	•	-	-			
411SE A4	-	-	-	-	-	-	-	-	-	-	-	-	-	-	-	-	-	-	-	•	•	•	•	-	-			
411SE A9	-	-	-	-	-	-	-	-	-	-	-	-	-	-	-	-	-	-	-	•	•	•	•	-	-			
288	•	•	•	•	•	•	•	•	•	•	•	•	•	•	•	•	•	•	•	•	•	•	•	•	•			
288YA46	•	•	•	•	•	•	•	•	•	•	•	•	•	•	•	•	•	•	•	•	•	•	•	•	•			
278CP05D1	-	-	-	-	-	-	-	-	-	-	-	-	-	-	-	-	-	-	-	-	•	•	•	•				
278CP05D2	-	-	-	-	-	-	-	-	-	-	-	-	-	-	-	-	-	-	-	-	•	•	•	•				





SIDE BENCH WITH ADJUSTABLE SQUARE AND WATER CONTAINMENT BARS FOR PIKUS, ZOE E SMS

MADE IN ITALY



- The side bench with adjustable square allow to have a perfect parallelism between the tile edge and the cutting line: this is extremely useful while performing either jolly/ 45° cut or 90° straight cut. Thanks to this accessory wet saws Pikus, Zoe and SMS become suitable for cutting jolly/45° on slabs having significant overall length (up to 200 cm).
- The two water containment bars with nylon brushes allows to reduce any leakage during the cut, making sure all water goes into machine tank.

Part No.			Description		
374BSQ 130	8024648099068	1	Side bench with adjustable square for Pikus 130 Adv, SMS 125 and Zoe 130 Adv	-	-
374BSQ 150	8024648099075	1	Side bench with adjustable square for SMS 150 and Zoe 150 Adv	-	-
374BSQ 220	8024648099082	1	Side bench with adjustable square for SMS 220	-	-
374BSQ 260	8050532001718	1	Side bench with adjustable square for SMS 260	-	-
263PE04A085	8024648019585	1	Water containment bars with nylon brushes for Pikus 85 Adv and Zoe 85 Adv – pair	120xØ 12,5 cm	47 1/4"xØ 5"
263PE04A105	8024648019592	1	Water containment bars with nylon brushes for Pikus 105 Adv, SMS 100 and Zoe 105 Adv – pair	120xØ 12,5 cm	47 1/4"xØ 5"
263PE04A130	8024648022233	1	Water containment bars with nylon brushes for Pikus 130 Adv, SMS 125 and Zoe 130 Adv – pair	165xØ 12,5 cm	65"xØ 5"
263PE04A150	8024648022851	1	Water containment bars with nylon brushes for SMS 150 and Zoe 150 Adv – pair	165xØ 12,5 cm	65"xØ 5"
263PE04A200	8024648026507	1	Water containment bars with nylon brushes for SMS 220 – pair	200xØ 12,5 cm	79"xØ 5"
263PE04A260	8050532001824	1	Water containment bars with nylon brushes for SMS 260 – pair	285xØ 12,5 cm	112"xØ 5"

Part No.	EXPLOIT			BOLT			MISTRAL			PIKUS				PIKUS ADV				SMS				ZOE ADV				SA	SA	SHERPA
	70	90	120	90	120	150	90	120	150	75	85	105	130	100	125	150	220	260	85	105	130	150	80	09				
374BSQ 130	-	-	-	-	-	-	-	-	-	-	-	-	•	-	•	-	-	-	-	-	-	•	-	-	-	-		
374BSQ 150	-	-	-	-	-	-	-	-	-	-	-	-	-	-	-	•	-	-	-	-	-	-	•	-	-	-		
374BSQ 220	-	-	-	-	-	-	-	-	-	-	-	-	-	-	-	-	•	-	-	-	-	-	-	-	-	-		
374BSQ 260	-	-	-	-	-	-	-	-	-	-	-	-	-	-	-	-	-	•	-	-	-	-	-	-	-	-		
263PE04A085	-	-	-	-	-	-	-	-	-	-	-	-	•	-	-	-	-	-	-	•	-	-	-	-	-	-		
263PE04A105	-	-	-	-	-	-	-	-	-	-	-	-	•	-	•	-	-	-	-	•	-	-	-	-	-	-		
263PE04A130	-	-	-	-	-	-	-	-	-	-	-	-	-	-	-	•	-	-	-	-	-	•	-	-	-	-		
263PE04A150	-	-	-	-	-	-	-	-	-	-	-	-	-	-	-	•	-	-	-	-	-	-	•	-	-	-		
263PE04A200	-	-	-	-	-	-	-	-	-	-	-	-	-	-	-	-	•	-	-	-	-	-	-	-	-	-		
263PE04A260	-	-	-	-	-	-	-	-	-	-	-	-	-	-	-	-	-	•	-	-	-	-	-	-	-	-		





MADE IN ITALY

BRIDGE AND JOB SITE SAW MACHINES



Part No.			Description
419AVBO=120	8024648090331	1	Wheel kit feed for Bolt 120
419AVBO=150	8024648090348	1	Wheel kit feed for Bolt 150
419AVMS=120	8024648090355	1	Wheel kit feed for Mistral 120/SMS 125
419AVMS=150	8024648090362	1	Wheel kit feed for Mistral 150
419AVMS=155	8024648022714	1	Wheel kit feed for SMS 150
419AVPK 085	8024648091543	1	Wheel kit feed for Pikus 85 Adv
419AVPK 105	8024648091550	1	Wheel kit feed for Pikus 105 Adv
419AVPK 130	8024648092755	1	Wheel kit feed for Pikus 130 Adv
419AVZO 085	8024648093233	1	Wheel kit feed for Zoe 85 Adv
419AVZO 105	8024648093240	1	Wheel kit feed for Zoe 105 Adv
419AVZO 130	8024648093257	1	Wheel kit feed for Zoe 130 Adv
419AVZO 150	8024648093264	1	Wheel kit feed for Zoe 150 Adv

Part No.	EXPLOIT			BOLT		MISTRAL			PIKUS			PIKUS ADV			SMS				ZOE ADV				SA	SA	SHERPA
	70	90	120	90	120	90	120	150	75	85	105	130	100	125	150	220	260	85	105	130	150	80	09		
419AVBO=120	-	-	-	-	•	-	-	-	-	-	-	-	-	-	-	-	-	-	-	-	-	-	-	-	
419AVBO=150	-	-	-	-	-	•	-	-	-	-	-	-	-	-	-	-	-	-	-	-	-	-	-	-	
419AVMS=120	-	-	-	-	-	-	•	-	-	-	-	-	-	•	-	-	-	-	-	-	-	-	-	-	
419AVMS=150	-	-	-	-	-	-	-	•	-	-	-	-	-	-	-	-	-	-	-	-	-	-	-	-	
419AVMS=155	-	-	-	-	-	-	-	-	-	-	-	-	-	-	•	-	-	-	-	-	-	-	-	-	
419AVPK 085	-	-	-	-	-	-	-	-	-	•	-	-	-	-	-	-	-	-	-	-	-	-	-	-	
419AVPK 105	-	-	-	-	-	-	-	-	-	-	•	-	-	-	-	-	-	-	-	-	-	-	-	-	
419AVPK 130	-	-	-	-	-	-	-	-	-	-	-	•	-	-	-	-	-	-	-	-	-	-	-	-	
419AVZO 085	-	-	-	-	-	-	-	-	-	-	-	-	-	-	-	-	-	-	•	-	-	-	-	-	
419AVZO 105	-	-	-	-	-	-	-	-	-	-	-	-	-	-	-	-	-	-	-	•	-	-	-	-	
419AVZO 130	-	-	-	-	-	-	-	-	-	-	-	-	-	-	-	-	-	-	-	-	•	-	-	-	
419AVZO 150	-	-	-	-	-	-	-	-	-	-	-	-	-	-	-	-	-	-	-	-	-	•	-	-	



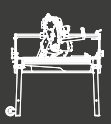

BRIDGE AND JOB SITE SAW MACHINES

ACCESSORIES FOR TROLLEY MACHINES

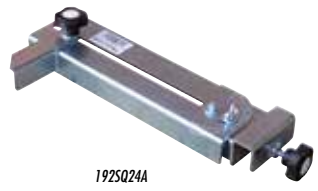

192SQ24A

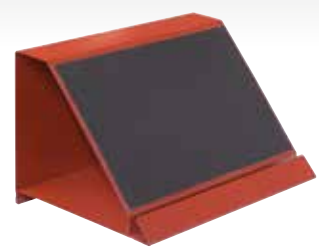

218DJ

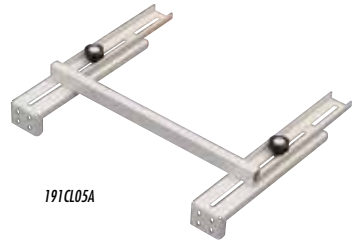

191CLO5A



288



288YA46



154SE17CP



411SE01A

Part No.			Description				
192SQ24A	8024648005656	1	Adjustable square 0/45°/90° for SA80, SA09, SHERPA	40x17xh 8 cm	16"x6 3/4"xh 3 1/8"	1,5 Kg	3.3 lbs
218DJ	8024648009777	1	Jolly device for SA09	71x23xh 11 cm	28"x9"xh 4"	4,4 Kg	9.7 lbs
154SE17CP	8024648066480	1	Handles for SA09	40x28xh 18 cm	15 3/4"x11"xh 7"	6 Kg	13 lbs
191CLO5A	8024648058003	1	Side square for SA80	68x66xh 10 cm	27"x26"xh 4"	4,5 Kg	9.9 lbs
411SE01A	8024648065254	1	Laser without stirrup	-	-	-	-
411SE A4	8024648070937	1	Laser with stirrup for SMS and SA80	-	-	-	-
411SE A3	8024648070920	1	Laser with stirrup for Sherpa	-	-	-	-
288	8024648004178	1	Dressing stone 30 x100xh 15 mm (1 3/16"x 4"xh 5/8")	-	-	-	-
288YA46	8024648079619	1	Dressing stone 45x230xh 25 mm (1 3/4"x9 1/16"xh 1")	-	-	-	-

Part No.	EXPLOIT			BOLT			MISTRAL			PIKUS	PIKUS ADV			SMS				ZOE ADV				SA	SA	SHERPA	
	70	90	120	90	120	150	90	120	150	75	85	105	130	100	125	150	220	260	85	105	130	150	80		09
192SQ24A	-	-	-	-	-	-	-	-	-	-	-	-	-	-	-	-	-	-	-	-	-	-	•	•	•
218DJ	-	-	-	-	-	-	-	-	-	-	-	-	-	-	-	-	-	-	-	-	-	-	-	•	-
154SE17CP	-	-	-	-	-	-	-	-	-	-	-	-	-	-	-	-	-	-	-	-	-	-	•	•	•
191CLO5A	-	-	-	-	-	-	-	-	-	-	•	•	•	•	•	•	•	•	•	•	•	•	•	•	•
411SE01A	-	-	-	-	-	-	-	-	-	-	-	-	-	-	-	-	-	-	-	-	-	-	-	-	
411SE A4	-	-	-	-	-	-	-	-	-	-	-	-	-	•	•	•	-	-	-	-	-	-	-	•	-
411SE A3	-	-	-	-	-	-	-	-	-	-	-	-	-	-	-	-	-	-	-	-	-	-	-	-	
288	•	•	•	•	•	•	•	•	•	•	•	•	•	•	•	•	•	•	•	•	•	•	•	•	•
288YA46	•	•	•	•	•	•	•	•	•	•	•	•	•	•	•	•	•	•	•	•	•	•	•	•	•

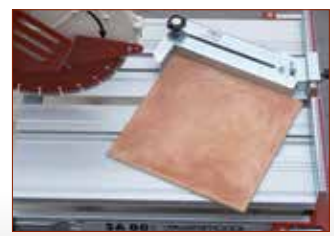

PORTABLE SAW MACHINES



PORTABLE SAW MACHINES

GS86.....	B2
ECO 92.....	B3
SUPERECO 98.....	B4



Three models to meet the needs of even those who favor machines with extremely compact cutting specifications and machine dimensions/weight and low weight; whose spearhead is the GS86: the super-professional compact saw machine which is an exceptional allied especially when wall coverings.

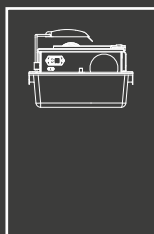



AVAILABLE BLADES

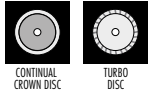

PACKAGE



TECHNICAL CHARACTERISTICS

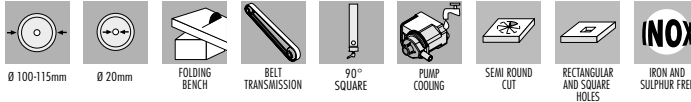

- For cutting porcelain, single-double fired, marble, granite.
Straight, 45° bevel (Jolly) cuts, square e round knockouts, sanding/polishing.
- Unlimited size of cut.
- Maximum thickness of cut: 25 mm (1") in single pass; 50 mm (2") in double pass.
- Maximum disc: Ø 115 mm (4 1/2"); smallest blade: Ø 100 mm (4").
- Gear ratio of motor to disc 1 ÷ 2.1. Drive belt type Z90.

- The blade is cooled via heavy duty pump.
- Supplied with: turbo blade Ø 115 mm (4 1/2") for tiles, 5 abrasive discs for polishing/sanding, key kit, dressing stone, user and maintenance manual.
- Turtle shell cover helps to prevent damage when not in use.

MODEL SPECIFICATIONS

Part No.	Barcode	Box	Lightning Bolt	M	Motor	Motor	Disc	Disc	
125INOX F	8024648003584	1	230 V 50 Hz	Single-phase	0,9 HP / 0,65 kW	2800	115 mm	4 1/2"	5800
125INOX 60	8024648017055	1	230 V 60 Hz	Single-phase	0,9 HP / 0,65 kW	3360	115 mm	4 1/2"	7000
125INOX US	8024648009265	1	110 V 60 Hz	Single-phase	0,9 HP / 0,65 kW	3360	115 mm	4 1/2"	7000
125INOX GB	8024648009258	1	110 V 50 Hz	Single-phase	0,9 HP / 0,65 kW	2800	115 mm	4 1/2"	5800

CUTTING SPECIFICATIONS AND MACHINE DIMENSIONS/WEIGHT

Model	Disc	Thickness	Width	Depth	Angle	Angle	Angle	Dimensions	Weight	Dimensions	Weight
GS86	100 mm 115 mm	4" 4 1/2"	18 mm 25 mm	25/32" 1"	10 mm 10 mm	4" 4"	∞ ∞ ∞	45x45xh 30 cm 18"x18"xh 12"	25 Kg 55.1 lbs	50x50xh 35 cm 20"x20"xh 13	26 Kg 57.3 lbs





AVAILABLE BLADES

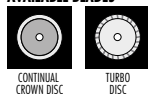

OPTIONAL



PACKAGE



TECHNICAL CHARACTERISTICS

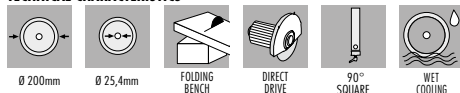

- For cutting single-double fired and porcelain. Straight cuts and 45° bevel (Jolly).
- Unlimited size of cut.
- Maximum thickness of cut: 20 mm (13/16") in single pass; 40 mm (1 5/8") in double pass.
- Maximum disc: Ø 150 mm (6").
- Blade is cooled through immersion in the water reservoir.

- Tilting table for bevel cuts from 0° to 47°.
- Supplied with: continuous rim blade for tiles Ø 150 mm (6"), key kit, dressing stone, user and maintenance manual.

MODEL SPECIFICATIONS

Part No.	Barcode	Box	Lightning Bolt	M	Motor	Motor	Disc	Disc	
370 DF	8024648003607	1	230 V 50/60 Hz	Single-phase	0,9 HP / 0,65 kW	2800/3360	200 mm	8"	2800/3360
370 USA	8024648010384	1	110 V 60 Hz	Single-phase	0,9 HP / 0,65 kW	3360	200 mm	8"	3360
370 GB	8024648009289	1	110 V 50 Hz	Single-phase	0,9 HP / 0,65 kW	2800	200 mm	8"	2800

CUTTING SPECIFICATIONS AND MACHINE DIMENSIONS/WEIGHT

Model	Disc	Thickness	Max Cut	Max Cut	Max Cut	Dimensions	Weight	Dimensions	Weight
ECO 92	200 mm 8"	36 mm 1 3/8"	40 mm 1 5/8"	∞	∞	47x45xh 27 cm 18 1/2"x18"xh 10 5/8"	16 Kg 35.3 lbs	50x50xh 32 cm 20"x20" xh 13"	17 Kg 37.5 lbs





AVAILABLE BLADES

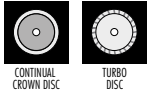

OPTIONAL



PACKAGE



TECHNICAL CHARACTERISTICS

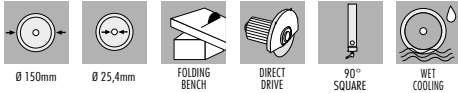

- For cutting single-double fired and porcelain. Straight cuts and 45° bevel (Jolly).
- Unlimited size of cut.
- Maximum thickness of cut: 20 mm (13/16") in single pass; 40 mm (1 5/8") in double pass.
- Maximum disc: Ø 150 mm (6").

- Blade is cooled through immersion in the water reservoir.
- Tilting table for bevel cuts from 0° to 47°.
- Supplied with: continuous rim blade for tiles Ø 150 mm (6"), key kit, dressing stone, user and maintenance manual.

MODEL SPECIFICATIONS

Part No.	Barcode	Box	Lightning Bolt	M	Motor	Motor	Disc	Disc	
378 98	8024648003621	1	230 V 50/60 Hz	Single-phase	0,5 HP / 0,37 kW	2800/3360	150 mm	6"	2800/3360
378 USA	8024648008824	1	110 V 60 Hz	Single-phase	0,33 HP / 0,24 kW	3360	150 mm	6"	3360
378 GB	8024648008800	1	110 V 50 Hz	Single-phase	0,33 HP / 0,24 kW	2800	150 mm	6"	2800

CUTTING SPECIFICATIONS AND MACHINE DIMENSIONS/WEIGHT

Model	Disc	Thickness	Depth	Angle	Angle	Angle	Dimensions	Weight	Dimensions	Weight
SUPERECO 98	150 mm 6"	20 mm 13/16"	30 mm 1 3/16"	∞	∞	∞	45x42xh 22 cm 17 3/4"x16 1/2"xh 8 5/8"	11 Kg 24 lbs	50x45xh 30 cm 19 5/8"x17 3/4"xh 11 7/8"	12 Kg 26 lbs

