

T8-G6001 Photoluminescent

The T8-G6001 High Performance Photoluminescent Guidance Strips provide excellent visibility and enhance egress speed in all light conditions. With its aluminum channel, the 1.2" wide T8-G6001 is UL 1994 listed and meets the requirements of building codes, fire codes and life safety codes across North America and around the world.

Engineered for Durability

- Manufactured using Ecoglo's patented process which produces the most durable and highly efficient photoluminescent product available.
- Unique ridges in the photoluminescent strips protect it from most abrasive wear.

Environmentally Friendly

- LEED points qualified
- Zero energy consumption
- Non-Radioactive and Non-toxic
- Recyclable; No disposable cost

For Indoor Use and Outdoor Use

- Tested to accelerated UV/weathering exposure, and proven to be highly resistant to the effects of UV/weathering.
- The loss in performance is less than can be detected by the human eye when subjected to 6000 hours of UV exposure, which is similar to 30 years of outdoor exposure.
- The polymer used in Ecoglo's patented process is "long chain" which forms a strong UV resistant product when bonding.

Qualifies for LEED Points

MR Credit 2: Construction Waste Management Divert from Land Fill

- Products are Aluminum based and 100% recyclable.

MR Credit 4: Recycled Content

- Products are Aluminum based and approximately 20% of the aluminum content in an Ecoglo secondary billet specification is recycled scrap.

Ecoglo's Recommended Installation Adhesive has low VOC's and qualifies for Indoor Environmental Quality credits for low emitting materials: EQc4.1

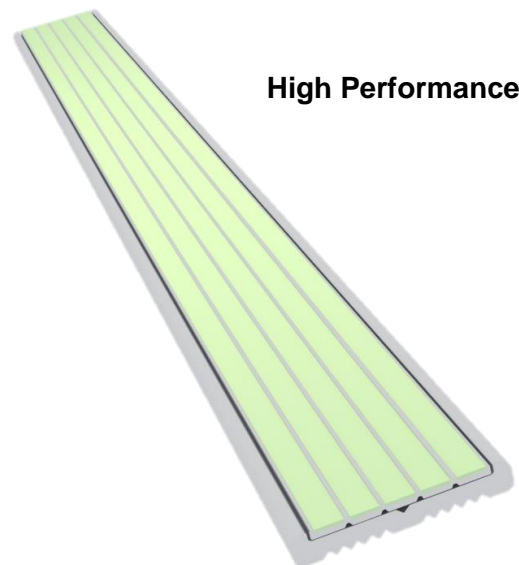

Product Dimensions

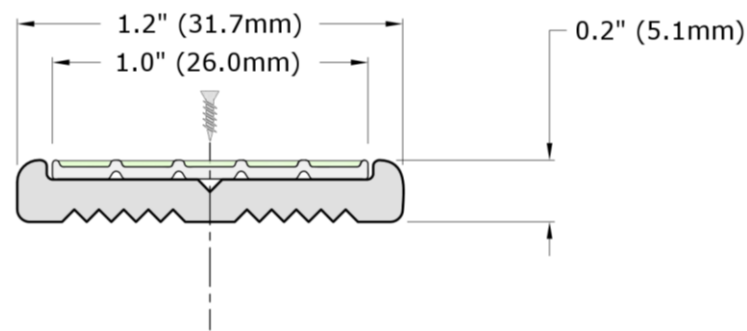

T8-G6001 Photoluminescent

The Ecoglo T8-G6001 meets the following Building, Fire & Life Safety Codes:

- IBC/IFC 2009, 2012 (Section 1024 – Luminous Egress Path Markings) and 2015 (Section 1025)
- NFPA 101-2009 and 170-2009
- NYC LL 141 of 2013 (Section BC 1024 Luminous Egress Path Markings)
- NYC LL 26 of 2004 Reference Standard 6-1
- California Building Code Section 1024 Exit Passageways
- Connecticut State Fire Safety Code Section 1026 Floor Proximity Egress Path Markings



How to Install:

- T8 Aluminum channel is installed using mechanical fasteners. The G6001 installs into the T8 channel using 3M tape.

General Information:

- Supplied in 10ft lengths.
- Pre-drilled with mechanical fasteners included. 3M double sided tape is pre-applied in the T8 aluminum channel

Benefits and Technical Details: Ecoglo T8-G6001 meets or exceeds the performance criteria specified in the following tests or standards:

Brightness

High visibility in dark or light conditions.

- ASTM E2073-02, Standard Test Method for Photopic Luminance of Photoluminescent (Phosphorescent) Markings.
- DIN 67510 Part 1, Phosphorescent Pigments and Products: Measurement and identification by the manufacturer.
- ISO 17398:2004 Clause 7.11, Safety Colors and Safety Signs- Classification, Performance and Durability of Safety Signs.

UV Stability

High durability indoors and outdoors.

- ASTM G155-04 Cycle 1 2000hrs, Standard Practice for Operating Xenon Arc Light Apparatus for Exposure of Nonmetallic Materials.
- Salt Spray Resistance: ASTM B117-97 500hrs, Standard Practice for Operating Salt Spray (Fog) Apparatus.
- Freeze-Thaw Resistance: ASTM C1026-87(1996), Standard Test Method for Measuring the Resistance of Ceramic Tile to Freeze-Thaw Cycling

Abrasion Resistance

Hard wearing.

- ASTM D1242-95a, Standard Test Methods for Resistance of Plastic Materials to Abrasion.
- ASTM F510-93(2004), Standard Test Method for Resistance to Abrasion of Resilient Floor Coverings Using an Abrader with a Grit Feed Method.
- JIS H8682-1:1999, Test methods for abrasion resistance of anodic oxide coatings on aluminum and aluminum alloys- Wheel wear test.

Washability

Easy Cleaning.

- ASTM D4828-94(2003), Standard Test Methods for Practical Washability of Organic Coatings.

Radioactivity

No radioactivity or toxicity.

- ASTM D3648-2004, Standard Practices for the Measurement of Radioactivity.
- Toxicity: Bombardier SMP 800-C (2000), Toxic Gas Generation Test.

Flammability

Does not burn.

- ASTM E162-02, Standard Test Method for Surface Flammability of Materials Using a Radiant Heat Energy Source.
- ASTM D635-03, Standard Test Method for Rate of Burning and/or Extent and Time of Burning of Plastics in a Horizontal Position.
- FAA AC 23.2 Paragraph 4.b, Horizontal Burn Test.

Contact Ecoglo Inc. for a quick quote or to obtain more information about our emergency lighting products.

Ecoglo Inc.

241 Main Street, Suite 100
Buffalo, New York 14203
USA

Phone: 888.679.4022

Fax: 877.679.4022

www.ecoglo.us

InfoEcoglo@Accessproducts.com