

Rev. Feb. 2021

JITOOOL

HEADQUARTERS

18 Jikdong-ro, Gwangju-si,
Gyeonggi-do, Korea

TEL : +82-2-445-2500

FAX : +82-2-445-2506

E-mail : jitool@jitool.com

JITOOOL USA CORP.

14408 Iseli Road,
Santa Fe Springs, CA 90670, USA

TEL : +1-562-404-8740

FAX : +1-562-404-8490

www.jitoolusa.com



Better Tool, Better Works!

www.jitoolusa.com

ABOUT US

Better Tool, Better Works! **JITOOL**

Established in 1983, JITOOL has been the leading manufacturer of pneumatic nailers and staplers in South Korea.

With more than 30 years of industrial fastening experience, JITOOL continuously strives to be a global leader in innovative fastening solutions.

With providing the best quality of service as JITOOL's highest priority, JITOOL and our R&D engineering and production teams seek to produce the best quality tools while continuously re-engineering and improving our products.

JITOOL products are all engineered, developed, and manufactured in South Korea.

JITOOL USA is headquartered in Santa Fe Springs, California serving customers all across North America.

We may not have been your first choice, but JITOOL is your best choice!



*JITOOL KOREA (FIRST)
JITOOL Factory for Tool*



*JITOOL KOREA (SECOND)
JITOOL Factory for Fastener*

CONTENTS

C-Ringer	_ 04
Cordless Pin Nailer	_ 06
Brad Nailer	_ 07
Framing Nailer	_ 08
Coil Nailer	_ 12
Stapler	_ 18
Micro Pinner	_ 32
Air Punch	_ 33

JC760

16GA. C-Ringer

- **Weight**
 - 3.48lbs(1.58kg)
- **Dimensions**
 - L: 10-13/16" (275mm)
 - H: 7-5/8" (194mm)
 - W: 3-13/16" (97mm)
- **Applications**
 - Small to Medium Bag Closure
 - Lobster, Shrimp and Crab traps
 - Netting
 - Bird control netting
 - Insulation
 - Automotive seat
- **Air Consumption**
 - 0.42L/cycle, 7kg/cm²

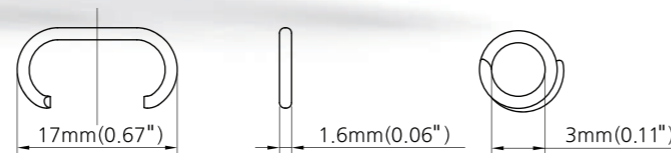

Mattress



Car seat performance



Fabric, Jute Netting

C-RINGER

JC7 _15GA. C-Ringer

- **Dimensions**
 - L: 7-3/8" (187mm) H: 13-7/16" (342mm) W: 3-1/2" (89mm)
- **Weight** - 3.4lbs(1.54kg)
- **Fasteners**
 - BOSTITCH : SC7
 - MEIHO : M-6W
- **Applications**
 - Automotive Seat
 - Mattress
 - Fence Connection
- **Air Consumption**
 - 0.42L/cycle, 7kg/cm²
- **Fastener Specification**

Type	15GA. C-Rings
Crown	.940" (23.9mm)
Wire Dia.	.070" (1.8mm)
Inner Diameter after Fastening	.315" (8mm)
Load Capacity	130



JC7C _15GA. C-Ringer

- **Dimensions**
 - L: 7-3/8" (187mm) H: 13-7/16"(342mm) W: 3-1/2" (89mm)
- **Weight** - 3.4lbs(1.54kg)
- **Fasteners**
 - BOSTITCH : SC7C
 - MEIHO : M-6CAW
- **Applications**
 - Automotive Seat
 - Mattress
 - Fence Connection
- **Air Consumption**
 - 0.42L/cycle, 7kg/cm²
- **Fastener Specification**

Type	15GA. C-Rings
Crown	.940" (23.9mm)
Wire Dia.	.070" (1.8mm)
Inner Diameter after Fastening	.200"~.240"(5mm~6mm)
Load Capacity	130



B635

23GA. 35mm Cordless Micro Pinner



Specifications :

- Protect for shooting without nails
- Lock function
- Alarm for overloading motor

Applications :

- Interior
- Molding / Picture Frame
- Finishing for furniture

CS26/38 _ Air Concrete Nailer

- Dimensions
 - L: 18-1/4" (464mm) H: 13-3/4" (349mm) W: 4-5/8" (117mm)
- Weight - 8.1 lbs(3.69kg)
- Fasteners
 - MAX : GS638E - Aerosmith PBC & RBC series
- Applications
 - Drywall track to concrete/ steel
 - Concrete furring
 - Wood to steel
- Air Consumption
 - 3.11L/cycle, 7kg/cm²
- Fastener Specification

Type	Concrete Pins
Length	1/2" ~ 1-1/2" (12mm ~ 38mm)
Shank Diameter	.104" ~ .114" (2.6mm ~ 2.9mm)
Head Diameter	.252" (6.4mm)
Load Capacity	42 Nails



• Magnesium Body

CS15/50 _ 15GA. Mini Concrete Nailer

- Dimensions
 - L: 11-7/16" (290mm) H: 10-5/8" (268mm) W: 3" (75.5mm)
- Weight - 3.8 lbs(1.72kg)
- Fasteners
 - BEA : SKS600
- Applications
 - For plinth and frame work
 - Interior and building finishing
 - Light steel connections
- Air Consumption
 - 1.16L/cycle, 7kg/cm²
- Fastener Specification

Type	15GA. Concrete Nails
Length	5/8" ~ 2" (15mm ~ 50mm)
Width x Thickness	.071" ~ .071" (1.8mm ~ 1.8mm)
Head Width	.130" (3.3mm)
Load Capacity	100 Nails



• Magnesium Body

FN21/90 _21° Full Round Head Framing Nailer

- **Dimensions**
- L: 19-11/16" (500mm) H: 13-27/32" (352mm) W: 4-5/8" (117mm)
- **Weight** - 8.4lbs(3.8kg)
- **Fasteners**
- BOSTITCH : N Series - MAX : SN Series
- SENCO : FramePro Series - HITACHI : NR83A
- **Applications**
- Framing/ Truss building
- Subflooring/ Fencing
- Sheathing and Decking/ Crating and Pallets
- **Air Consumption**
- 3.11L/cycle, 7kg/cm²
- **Fastener Specification**



• Magnesium Body

Type	21° Plastic Collated Full Round Head Nails
Length	2" ~ 3-1/2" (50mm ~ 90mm)
Shank Dia.	.113" ~ .131" (2.9mm ~ 3.3mm)
Head Dia.	.267" ~ .295" (6.8mm ~ 7.5mm)
Load Capacity	64 Nails

CT64R3 _14GA. 64mm Brad & Concrete Nailer

- **Dimensions**
- L: 12-7/16" (316mm) H: 12-3/16" (310mm) W: 4" (101mm)
- **Weight** - 5.54 lbs(2.47kg)
- **Fasteners**
- PASLODE : 3250-F14 404677 Series
- **Applications**
DT - Window & Door Molding
- Cabinet Framing /Furniture Trim
ST - Trusses Building
- Wood to Concrete/ Finish Construction
- **Air Consumption**
- 1.96L/cycle, 7kg/cm²
- **Fastener Specification**



• Magnesium Body

Length	DT : 1-3/16" ~ 2-1/2" (30mm ~ 64mm) ST : 3/4" ~ 2-1/2" (18mm ~ 64mm)
Width x Thickness	DT : .064" x .086" (1.65mm x 2.2mm) ST : .086" x .086" (2.2mm x 2.2mm)
Head Width	DT : .153" (3.9mm) ST : .256" (6.5mm)
Load Capacity	80 Nails

FN34/90 _34° Clipped Head Framing Nailer

- **Dimensions**
- L: 17-9/16" (446mm) H: 14-9/32" (363mm) W: 4-5/8" (117mm)
- **Weight** - 8.4lbs(3.8kg)
- **Fasteners**
- BOSTITCH : N Series - MAX : SN Series
- SENCO : FramePro Series - HITACHI : NR83AA
- **Applications**
- Framing/ Truss building
- Subflooring/ Fencing
- Sheathing and Decking/ Crating and Pallets
- **Air Consumption**
- 3.11L/cycle, 7kg/cm²
- **Fastener Specification**



• Magnesium Body

Type	34° Paper Collated Clipped Head Nails
Length	2" ~ 3-1/2" (50mm ~ 90mm)
Shank Dia.	.113" ~ .131" (2.9mm ~ 3.3mm)
Head Dia.	.267" ~ .303" (6.8mm ~ 7.7mm)
Load Capacity	90 Nails

IN160 _Insulation Nailer

- **Dimensions**
- L: 17-11/16"(449mm) H: 12-7/8" (328mm) W: 4-13/16 "(123mm)
- **Weight** - 7.05lbs(3.2kg)
- **Fasteners**
- Insulation Nails
- **Applications**
- Fix the insulation layer on the concrete and brick
- **Air Consumption**
- 5.01L/cycle, 7kg/cm²
- **Fastener Specification**



• Magnesium Body

Type	Insulation Nails
Length	1-3/16" ~ 6-5/16" (30mm ~ 160mm)
Shank Dia.	.138" (3.5mm)
Head Dia.	.291" (7.4mm)
Load Capacity	1 Nail

BN16/50 _16GA. Finish Nailer

- **Dimensions**
 - L: 11-1/4" (286mm) H: 10-5/8" (268mm) W: 3" (75.5mm)
- **Weight** - 3.8lbs(1.72kg)
- **Fasteners**
 - BEA : SK400 Series
 - HITACHI : 142 Series
 - POTER CABLE : FN16 Series
- **Applications**
 - Molding & Decorative Trim
 - Furniture Trim/ Component Assembly
 - Door & Window Casings/ Picture Frame Assembly
- **Air Consumption**
 - 1.16L/cycle, 7kg/cm²
- **Fastener Specification**



• Magnesium Body

Type	16GA. Finish Nails
Length	3/4" ~ 2" (19mm ~ 50mm)
Width x Thickness	.055" x .063" (1.4mm x 1.6mm)
Head Width	.114" (2.9mm)
Load Capacity	100 Nails

F30 _18GA. 1-3/16" Brad Nailer

10/11

- **Dimensions**
 - L: 9-11/32" (239mm) H: 7-7/16" (189mm) W: 2-3/8" (60mm)
- **Weight** - 2.42lbs(1.1kg)
- **Fasteners**
 - MAX : TA20A Series
 - HITACHI : NT Series
- **Applications**
 - Molding & Decorative Trim
 - Furniture Trim
 - Interior Trim & Exterior Trim
- **Air Consumption**
 - 0.42L/cycle, 6kg/cm²
- **Fastener Specification**



Type	18GA. Brad Nails
Length	3/8" ~ 1-3/16" (10mm ~ 30mm)
Width x Thickness	.040" x .050" (1.05mm x 1.25mm)
Head Width	.078" (2mm)
Load Capacity	100 Nails

BN16/64 _16GA. Finish Nailer

- **Dimensions**
 - L: 11-1/4" (286mm) H: 11-1/8" (282mm) W: 3" (75.5mm)
- **Weight** - 3.92lbs(1.78kg)
- **Fasteners**
 - BEA : SK400 Series
 - HITACHI : 142 Series
 - POTER CABLE : FN16 Series
- **Applications**
 - Molding & Decorative Trim
 - Furniture Trim/ Component Assembly
 - Door & Window Casings/ Picture Frame Assembly
- **Air Consumption**
 - 1.20L/cycle, 7kg/cm²
- **Fastener Specification**



• Magnesium Body

Type	16GA. Finish Nails
Length	3/4" ~ 2-1/2" (19mm ~ 64mm)
Width x Thickness	.055" x .063" (1.4mm x 1.6mm)
Head Width	.114" (2.9mm)
Load Capacity	100 Nails

1850NL _18GA. 2" Brad Nailer

- **Dimensions**
 - L: 9-5/8" (244mm) H: 9-5/8" (244mm) W: 2-5/16" (62mm)
- **Weight** - 3.06lbs(1.39kg)
- **Fasteners**
 - MAX : NF255-ST/18 Series
 - HITACHI : NT Series
- **Applications**
 - Molding, Decorative Trim
 - Mirror & Picture Frames
 - Interior Trim & Exterior Trim
- **Air Consumption**
 - 0.56L/cycle, 6kg/cm²
- **Fastener Specification**



Type	18GA. Brad Nails
Length	3/4" ~ 2" (19mm ~ 50mm)
Width x Thickness	.040" x .050" (1.05mm x 1.25mm)
Head Width	.078" (2mm)
Load Capacity	100 Nails

JCN70PAL / JCN80PAL

Machine-Mounted Coil Nailer



• Features

- Machine Mounted
- Fast Cycle System
- For High Speed Machine Applications

• Applications

- Machine-Mounted
- Pallet Assembly
- Crate Assembly
- Manufactured Housing

• Fastener Specifications

15 Degree Flat Wire Welded Nails

Head Diameter
 $\varnothing .224" \sim \varnothing .283"$
 $(\varnothing 5.7\text{mm} \sim \varnothing 7.2\text{mm})$

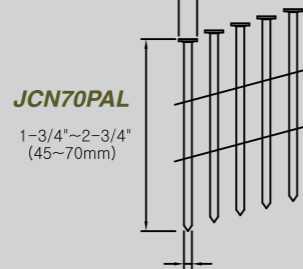

JCN70PAL
 $1\text{-}3/4" \sim 2\text{-}3/4"$
 $(45 \sim 70\text{mm})$

Shank Diameter $\varnothing .090" \sim \varnothing .113"$
 $(\varnothing 2.3 \sim \varnothing 2.9\text{mm})$

Head Diameter
 $\varnothing .224" \sim \varnothing .283"$
 $(\varnothing 5.7\text{mm} \sim \varnothing 7.2\text{mm})$

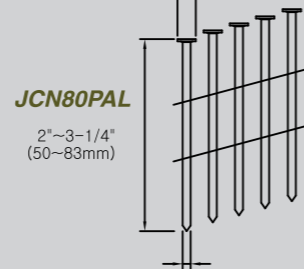

JCN80PAL
 $2" \sim 3\text{-}1/4"$
 $(50 \sim 83\text{mm})$

Shank Diameter $\varnothing .099" \sim \varnothing .131"$
 $(\varnothing 2.5 \sim \varnothing 3.3\text{mm})$

JN65S _Siding Coil Nailer

- Dimensions
 - L: 10-11/32" (263mm) H: 12" (305mm) W: 5-5/16" (134mm)
- Weight - 4.6lbs(2.1kg)
- Fasteners
 - BOSTITCH : N66C
 - MAX : CN565S
 - HITACHI : NV65AH
- Applications
 - General construction work including siding
 - Decking/ Panel sheathing
- Air Consumption
 - 1.57L/cycle, 7kg/cm²
- Fastener Specification

Type 15° Flat Wire Welded Nails/ 15° Flat Plastic Sheet Collated Nails

Length Flat Wire : 1-3/4" ~ 2-1/2" (45mm ~ 65mm)
 Flat Plastic : 1-1/4" ~ 2-1/2" (32mm ~ 65mm)

Shank Dia. .092"~ .099" (2.3mm x 2.5mm)

Head Dia. .197"~ .236" (5.0~6.0mm)

Load Capacity 200~300 Nails



• Magnesium Body

JN45R _Roofing Coil Nailer

- Dimensions
 - L: 10-1/2" (267mm) H: 10-1/2" (267mm) W: 4-7/16" (113mm)
- Weight - 4.98lbs(2.26kg)
- Fasteners
 - BOSTITCH : RN45B - MAX : CN 450R, CN445R
 - SENCO : RoofPro Series - HITACHI : NV45 Series
- Applications
 - Siding Installation
 - Wooden Box Assembly
 - Fastening asphalt & fiberglass shingles
- Air Consumption
 - 1.52L/cycle, 7kg/cm²
- Fastener Specification

Type 15° Roofing Coil Nails

Length 3/4" ~ 1-3/4" (19mm ~ 45mm)

Shank Dia. .120" (3.05mm)

Head Dia. .413" (10.5mm)

Load Capacity 120 Nails



• Magnesium Body

JCN55 _Industrial Coil Nailer

- Dimensions

- L: 10-5/8" (270mm) H: 11-5/8" (283mm) W: 5-1/8" (131mm)

- Weight - 5.5lbs(2.5kg)

- Fasteners

- MAX : CN55

- Applications

- Making and Repairing wooden pallets and boxes
- Types of packing and crating work
- Fencing, framing, roof decking, flooring
- Flooring and building a wooden wall

- Air Consumption

- 1.56L/cycle, 7kg/cm²

- Fastener Specification

Type	15° Flat Wire Welded Nails
Length	1" ~ 2-1/4" (25mm ~ 57mm)
Shank Dia.	.083"~ .090" (2.1mm~2.3mm)
Head Dia.	.197"~ .224" (5.0mm~5.7mm)
Load Capacity	300~400 Nails



JCN70 _Industrial Coil Nailer

- Dimensions

- L: 12-1/16"(306mm) H: 12-7/16" (315mm) W: 5" (128mm)

- Weight - 7.6lbs(3.5kg)

- Fasteners

- MAX : CN70

- Applications

- Making and Repairing wooden pallets and boxes
- Types of packing and crating work
- Fencing, framing, roof decking, flooring
- Flooring and building a wooden wall

- Air Consumption

- 2.48L/cycle, 7kg/cm²

- Fastener Specification

Type	15° Flat Wire Welded Nails
Length	1-3/4" ~ 2-3/4" (45mm ~ 70mm)
Shank Dia.	.090"~ .113" (2.3mm~2.9mm)
Head Dia.	.224"~ .283" (5.7mm~7.2mm)
Load Capacity	225~300 Nails



JCN65 _Industrial Coil Nailer

- Dimensions

- L: 11-3/4 "(298.8mm) H: 12" (305.7mm) W: 5" (127.6mm)

- Weight - 6.5lbs(2.94kg)

- Fasteners

- EVERWIN : PN65M - MAX : CN665

- Applications

- Making and Repairing wooden pallets and boxes
- Types of packing and crating work
- Fencing, framing, roof decking, flooring
- Flooring and building a wooden wall

- Air Consumption

- 2.08L/cycle, 7kg/cm²

- Fastener Specification

Type	15° Flat Wire Welded Nails
Length	1-1/2" ~ 2-1/2" (38mm ~ 65mm)
Shank Dia.	.090"~ .113" (2.3mm~2.9mm)
Head Dia.	.224"~ .283" (5.7mm~7.2mm)
Load Capacity	225~300 Nails



JCN80 _Industrial Coil Nailer

- Dimensions

- L: 13-13/16" (351mm) H: 13-1/4" (336.5mm) W: 5-3/8" (137mm)

- Weight - 8.3lbs(3.76kg)

- Fasteners

- MAX : CN80

- HITACHI : NV83

- Applications

- Making and Repairing wooden pallets and boxes
- All Types of packing and crating work
- Fencing, framing, roof decking, flooring

- Air Consumption

- 2.65L/cycle, 7kg/cm²

- Fastener Specification

Type	15° Flat Wire Welded Nails
Length	2" ~ 3-1/4" (50mm ~ 83mm)
Shank Dia.	.099"~ .131" (2.5mm~3.3mm)
Head Dia.	.224"~ .283" (5.7mm~7.2mm)
Load Capacity	250~300 Nails



JCN70PAL _Machine-Mounted Coil Nailer

- **Dimensions**
- L: 12-1/16"(306mm) H: 12-7/16" (315mm) W: 4-7/16" (113mm)
- **Weight** - 6.6lbs(3.0kg)
- **Fasteners**
- MAX : CN70
- **Applications**
- Machine-Mounted
- Pallet Assembly
- Crate Assembly
- Manufactured Housing
- **Air Consumption**
- 2.48L/cycle, 7kg/cm²
- **Fastener Specification**



Type	15° Flat Wire Welded Nails
Length	1-3/4" ~ 2-3/4" (45mm ~ 70mm)
Shank Dia.	.090"~ .113" (2.3mm~2.9mm)
Head Dia.	.224"~ .283" (5.7mm~7.2mm)
Load Capacity	225~300 Nails

JN55C _Industrial Coil Nailer

16/17

- **Dimensions**
- L: 10-3/4" (273mm) H: 10-19/32" (269mm) W: 5-5/16" (135mm)
- **Weight** - 5.8lbs(2.63kg)
- **Fasteners**
- MAX : CN55 - BOSTITCH : N57C
- SENCO : PalletPro 57F
- **Applications**
- Making wooden crate
- Making and Repairing Pallets
- Fencing, Siding , Decking and Sheathing
- **Air Consumption**
- 1.50L/cycle, 7kg/cm²
- **Fastener Specification**



Type	15° Flat Wire Welded Nails
Length	1" ~ 2-1/4" (25mm ~ 57mm)
Shank Dia.	.083"~ .090" (2.1mm~2.3mm)
Head Dia.	.197"~ .224" (5.0mm~5.7mm)
Load Capacity	300~400 Nails

JCN80PAL _Manufactured Housing Coil Nailer

- **Dimensions**
- L: 13-13/16" (351mm) H: 13-1/4" (336.5mm) W: 4-7/16" (113mm)
- **Weight** - 7.3lbs(3.3kg)
- **Fasteners**
- MAX : CN80 - HITACHI : NV83
- **Applications**
- Machine-Mounted
- Pallet Assembly
- Crate Assembly
- Manufactured Housing
- **Air Consumption**
- 2.65L/cycle, 7kg/cm²
- **Fastener Specification**



Type	15° Flat Wire Welded Nails
Length	2" ~ 3-1/4" (50mm ~ 83mm)
Shank Dia.	.099"~ .131" (2.5mm~3.3mm)
Head Dia.	.224"~ .283" (5.7mm~7.2mm)
Load Capacity	250~300 Nails

JN100C _Industrial Coil Nailer

- **Dimensions**
- L: 14-7/8" (378mm) H: 15-15/16" (405mm) W: 6" (153mm)
- **Weight** - 12.4lbs(5.6kg)
- **Fasteners**
- MAX : CN100
- **Applications**
- Making wooden pallets
- Heavy duty wooden boxes
- Crating
- Packaging
- **Air Consumption**
- 4.84L/cycle, 7kg/cm²
- **Fastener Specification**



Type	15° Flat Wire Welded Nails
Length	2-1/2" ~ 4" (65mm ~ 100mm)
Shank Dia.	.113"~ .131" (2.9mm ~ 3.3mm)
Head Dia.	.276"~ .295" (7.0mm ~ 7.5mm)
Load Capacity	200~250 Nails

JNS50HD

16GA. 7/16" Medium Crown Stapler

HEAVY DUTY



● Features

- Quick Firing Trigger System
- End cap filter included
- Easily accessible jam clearing system
- Trigger locking mechanism
- Adjustable depth control
- Easy bolt on/off system for clearing jams
- Equipped with a covered guide body for heavy duty and high speed operations.

● Applications

- Flooring and building a wooden wall
- Fencing, framing, roof decking, flooring
- Types of packing and crating work
- Making and Repairing wooden pallets and boxes

JNS45 _16GA. 7/16" Medium Crown Stapler

18/19

● Dimensions

- L: 13-3/4"(349mm) H: 11-3/4" (298mm) W: 3-11/16" (94mm)

● Weight - 4.9lbs(2.22kg)

● Fasteners

- MAX : TA551 - SENCO : SNS45XP/N
- HITACHI : N5008AC/11200

● Applications

- Sheathing and Subflooring
- Roof Decking - Crate & Wooden box
- Furniture & Pallets

● Air Consumption

- 1.64L/cycle, 7kg/cm²

● Fastener Specification

Type	16GA. 7/16" Medium Crown Staples
Length	1"~ 2" (25mm~50mm)
Crown	7/16" (11.1mm)
Width x Thickness	.055" x .062" (1.4mm~1.57mm)
Load Capacity	160



JNS45L _16GA. 7/16" Medium Crown Double Length Magazine Stapler

● Dimensions

- L: 23-7/32" (590mm) H: 11-3/4"(298mm) W: 3-11/16" (94mm)

● Weight - 7.38lbs(3.35kg)

● Fasteners

- MAX : TA551
- SENCO : SNS45XP/N

● Applications

- Furniture & Pallets
- Machine Automation

● Air Consumption

- 1.64L/cycle, 7kg/cm²

● Fastener Specification

Type	16GA. 7/16" Medium Crown Staples
Length	1"~ 2" (25mm~50mm)
Crown	7/16" (11.1mm)
Width x Thickness	.055" x .062" (1.4mm~1.57mm)
Load Capacity	320



JNS50 _16GA. 7/16" Medium Crown Stapler

- **Dimensions**
- L: 11-5/8" (294.5mm) H: 13-15/16" (353.5mm) W: 3-4/16" (81mm)
- **Weight** - 5.07lbs(2.3kg)
- **Fasteners**
- MAX:TA551 - HITACHI:N5008AC/11200 - SENCO:SNS45XP/N
- **Applications**
- Flooring and building a wooden wall
- Fencing, framing, roof decking, flooring
- Types of packing and crating work
- Making and Repairing wooden pallets and boxes
- **Air Consumption**
- 1.42L/cycle, 7kg/cm²
- **Fastener Specification**



Type	16GA. 7/16" Medium Crown Staples
Length	1"~ 2" (25mm~50mm)
Crown	7/16" (11.1mm)
Width x Thickness	.055" x .062" (1.4mm x 1.57mm)
Load Capacity	160

JPS38 _16GA. 1" Wide Crown Stapler

20/21

- **Dimensions**
- L: 10-5/16" (262mm) H: 14-5/16" (364mm) W: 3" (76mm)
- **Weight** - 5.0lbs(2.28kg)
- **Fasteners**
- SENCO: PW150R/P - HITACHI: N5024A/11300
- DUO FAST: RNS17481/1716CGR
- **Applications**
- General construction works
- Lathing
- Sheathing
- **Air Consumption**
- 1.17L/cycle, 7kg/cm²
- **Fastener Specification**



• Magnesium Body

Type	16GA. 1" Wide Crown Staples
Length	3/4" ~ 1-1/2" (19mm ~ 38mm)
Crown	1" (26.2mm)
Width x Thickness	.055" x .062" (1.40mm x 1.57mm)
Load Capacity	160

JNS50HD _16GA. 7/16" Medium Crown Stapler HEAVY DUTY

- **Dimensions**
- L: 11-5/8" (294.5mm) H: 13-15/16" (353.5mm) W: 3-4/16" (81mm)
- **Weight** - 5.07lbs(2.3kg)
- **Fasteners**
- MAX:TA551 - HITACHI:N5008AC/11200 - SENCO:SNS45XP/N
- **Applications**
- Flooring and building a wooden wall
- Fencing, framing, roof decking, flooring
- Types of packing and crating work
- Making and Repairing wooden pallets and boxes
- **Air Consumption**
- 1.42L/cycle, 7kg/cm²
- **Fastener Specification**



Type	16GA. 7/16" Medium Crown Staples
Length	1"~ 2" (25mm~50mm)
Crown	7/16" (11.1mm)
Width x Thickness	.055" x .062" (1.4mm x 1.57mm)
Load Capacity	160

JPS38R _16GA. 1" Wide Crown Roofing Stapler

- **Dimensions**
- L: 14-7/16" (367mm) H: 10-3/8" (263mm) W: 3-17/32" (90mm)
- **Weight** - 5.3lbs(2.40kg)
- **Fasteners**
- SENCO : PW150R/P - HITACHI : N5024A/11300
- DUO FAST : RNS-17481/1716CGR Series
- **Applications**
- Fastening asphalt & fiberglass Roof shingles
- Construction
- Wooden working-furniture, Box assembly
- **Air Consumption**
- 1.17L/cycle, 7kg/cm²
- **Fastener Specification**



• Magnesium Body

Type	16GA. 1" Wide Crown Staples
Length	3/4" ~ 1" (19mm ~ 38mm)
Crown	1" (26.2mm)
Width x Thickness	.055" x .062" (1.40mm x 1.57mm)
Load Capacity	160

TRS25S_16GA. 1" Wide Crown Stapler

- Dimensions
 - L: 14-13/16" (376mm) H: 9" (229mm) W: 3-17/32" (90mm)
- Weight - 5.35lbs(2.43kg)
- Fasteners
 - SENCO : P Series
- Applications
 - Truss
 - Sheathing
 - Furniture framing
 - General construction works
- Air Consumption
 - 0.98L/cycle, 7kg/cm²
- Fastener Specification



• Magnesium Body

Unrestricted Quick Firing trigger system.

Type	16GA. 1" Wide Crown Staples
Length	1/2" ~ 1" (13mm ~ 25mm)
Crown	1" (26.2mm)
Width x Thickness	.055" x .062" (1.4mm x 1.57mm)
Load Capacity	160

TRS25SB_16GA.1" Wide Crown Stapler HEAVY DUTY

- Dimensions
 - L: 14-13/16" (376mm) H: 9" (229mm) W: 3-17/32" (90mm)
- Weight - 5.35lbs(2.43kg)
- Fasteners
 - SENCO : P Series
- Applications
 - Truss
 - Sheathing
 - Furniture framing
 - General construction works
- Air Consumption
 - 0.98L/cycle, 7kg/cm²
- Fastener Specification



• Magnesium Body

Unrestricted Quick Firing trigger system.

Type	16GA. 1" Wide Crown Staples
Length	1/2" ~ 1" (13mm ~ 25mm)
Crown	1" (26.2mm)
Width x Thickness	.055" x .062" (1.4mm x 1.57mm)
Load Capacity	160

TRS25B_16GA. 1" Wide Crown Stapler

- Dimensions
 - L: 14-13/16" (376mm) H: 9" (229mm) W: 3-17/32" (90mm)
- Weight - 5.31lbs(2.41kg)
- Fasteners
 - BOSTITCH : BCS(16S2) Series
- Applications
 - Truss
 - Sheathing
 - Furniture framing
 - General construction works
- Air Consumption
 - 0.98L/cycle, 7kg/cm²
- Fastener Specification



• Magnesium Body

Unrestricted Quick Firing trigger system.

Type	16GA. 1" Wide Crown Staples
Length	1/2" ~ 1" (13mm ~ 25mm)
Crown	1" (25mm)
Width x Thickness	.055" x .062" (1.4mm x 1.57mm)
Load Capacity	160

TRS38S_16GA.1" Wide Crown Stapler

- Dimensions
 - L: 14-1/4"(362mm) H: 10-5/16"(262mm) W: 3"(76mm)
- Weight - 5.3lbs(2.42kg)
- Fasteners
 - DUO FAST : RNS-17481/1716CGR
 - HITACHI : N5024A/11300 - SENCO : PW/P Series
- Applications
 - Lathing & Insulation
 - Construction - Box Assembly
 - Wooden working-furniture
- Air Consumption
 - 1.17L/cycle, 7kg/cm²
- Fastener Specification



• Magnesium Body

Unrestricted Quick Firing trigger system.

Type	16GA. 1" Wide Crown Staples
Length	3/4" ~ 1-1/2"(19mm~38mm)
Crown	1" (26.2mm)
Width x Thickness	.055" x .062" (1.4mm~1.57mm)
Load Capacity	160

JLS38N _18GA. 1/4" Narrow Crown Stapler Rapid Fire

- Dimensions
 - L: 12-1/8"(307mm) H: 9-5/16" (236mm) W: 2-3/8" (60mm)
- Weight - 2.95lbs(1.35kg)
- Fasteners
 - BEA : NS/90 Series - SENCO : SLS/L Series
 - DUO FAST : SURESHOT 1820/1800
- Applications
 - Cabinets
 - Wooden Crate
 - Furniture Manufacturing
- Air Consumption
 - 0.69L/cycle, 7kg/cm²
- Fastener Specification

Type	18GA. 1/4" Narrow Crown Staples
Length	1/2"~ 1-1/2" (13mm~38mm)
Crown	1/4" (5.8mm)
Width x Thickness	.044"x .050" (1.1mm x 1.27mm)
Load Capacity	170



JQS65 _15GA.7/16" Crown Stapler

- Dimensions
 - L: 14-1/4" (362mm) H: 12-13/16" (326mm) W: 4" (101mm)
- Weight - 5.51lbs(2.5kg)
- Fasteners
 - SENCO : SQS 55XP
- Applications
 - Sheathing
 - Sub-flooring
 - Furniture Framing
 - Pallet & Box Assembly
- Air Consumption
 - 1.96L/cycle, 7kg/cm²
- Fastener Specification

Type	15GA. 7/16" Crown Staples
Length	1-1/4"~ 2-1/2" (32mm~65mm)
Crown	7/16" (11.1mm)
Width x Thickness	.067"x .074" (1.70mm x 1.88mm)
Load Capacity	130



• Magnesium Body

JLS38S _18GA. 1/4" Narrow Crown Stapler

- Dimensions
 - L: 12-1/8"(307mm) H: 9-5/16" (236mm) W: 2-3/8" (60mm)
- Weight - 2.95lbs(1.35kg)
- Fasteners
 - BEA : NS/90 Series - SENCO : SLS/L Series
 - DUO FAST : SURESHOT 1820/1800
- Applications
 - Cabinets
 - Wooden Crate
 - Furniture Manufacturing
- Air Consumption
 - 0.69L/cycle, 7kg/cm²
- Fastener Specification

Type	18GA. 1/4" Narrow Crown Staples
Length	1/2"~ 1-1/2" (13mm~38mm)
Crown	1/4" (5.8mm)
Width x Thickness	.044"x .050" (1.1mm x 1.27mm)
Load Capacity	170



JQS65B _15GA.1/2" Crown Stapler

- Dimensions
 - L: 14-1/4" (362mm) H: 12-13/16" (326mm) W: 4" (101mm)
- Weight - 5.51lbs(2.5kg)
- Fasteners
 - BOSTITCH : 863S4-1
- Applications
 - Sheathing
 - Sub-flooring
 - Furniture Framing
 - Pallet & Box Assembly
- Air Consumption
 - 1.96L/cycle, 7kg/cm²
- Fastener Specification

Type	15GA. 1/2" Crown Staples
Length	1-1/4"~ 2-1/2" (32mm~65mm)
Crown	1/2" (12.7mm)
Width x Thickness	.067"x .074" (1.70mm x 1.88mm)
Load Capacity	130



• Magnesium Body

722 _18GA. 0.34" Crown Stapler

- Dimensions
 - L: 9-1/2" (242mm) H: 7-1/16" (179mm) W: 2-3/8" (60mm)
- Weight - 2.65lbs(1.2kg)
- Fasteners
 - MAX : TA-35A/722M
- Applications
 - Upholstery & Bedding
 - Furniture Manufacturing
- Air Consumption
 - 0.42L/cycle, 6kg/cm²

● Fastener Specification

Type	18GA. 0.34" Crown Staples
Length	3/8" ~ 7/8" (10mm ~ 22mm)
Crown	0.34" (8.6mm)
Width x Thickness	.040" x .050" (1.05mmx1.25mm)
Load Capacity	92



JS16-50 _20GA. 1/2" Crown Stapler

- Dimensions
 - L: 8-15/16" (227mm) H: 6-13/16" (147mm) W: 1-7/8" (47mm)
- Weight - 1.98lbs(0.90kg)
- Fasteners
 - BEA : 95 Series
 - DUO FAST : SureShot 5020/5000
- Applications
 - Upholstery & Bedding
 - Furniture Manufacturing
- Air Consumption
 - 0.17L/cycle, 6kg/cm²

● Fastener Specification

Type	20GA. 1/2" Crown Staples
Length	3/16" ~ 5/8" (5mm ~ 16mm)
Crown	1/2" (12.5mm)
Width x Thickness	.019" x .050" (0.55mm x 1.27mm)
Load Capacity	95



JS16-34M _22GA. 3/16" Crown Stapler

- Dimensions
 - L: 8-15/16" (227mm) H: 5-13/16" (147mm) W: 1-7/8" (47mm)
- Weight - 2.07lbs(0.94kg)
- Fasteners
 - SENCO : A Series
- Applications
 - Upholstery & Bedding
 - Furniture Manufacturing
- Air Consumption
 - 0.17L/cycle, 6kg/cm²

● Fastener Specification

Type	22GA. 3/16" Crown Staples
Length	5/32" ~ 5/8" (4mm ~ 16mm)
Crown	3/16" (4.7mm)
Width x Thickness	.022" x .030" (0.55mmx0.76mm)
Load Capacity	175



JS16-54 _20GA. 3/16" Crown Stapler

- Dimensions
 - L: 8-15/16" (227mm) H: 5-13/16" (147mm) W: 1-7/8" (47mm)
- Weight - 1.98lbs(0.90kg)
- Fasteners
 - DUO FAST : SureShot 5254/5400
- Applications
 - Upholstery & Bedding
 - Furniture Manufacturing
- Air Consumption
 - 0.17L/cycle, 6kg/cm²

● Fastener Specification

Type	20GA. 3/16" Crown Staples
Length	5/32" ~ 5/8" (4mm ~ 16mm)
Crown	3/16" (4.5mm)
Width x Thickness	.019" x .050" (0.55mm x 1.27mm)
Load Capacity	95



S71/16-22 ALM

22GA. 3/8" Crown Double Length Magazine Auto Stapler

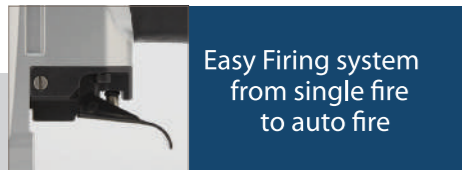

Easy Firing system
from single fire
to auto fire

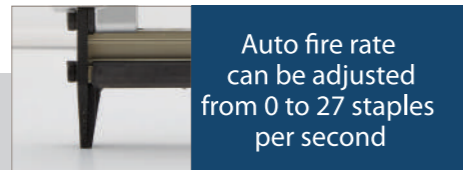

Auto fire rate
can be adjusted
from 0 to 27 staples
per second



Same hand
magazine pinky
release

• Features

- Easy Firing System
- Extended Magazine
- Durable Metal Magazine
- Easy Magazine On/Off system
- Auto fire rate can be adjusted from 0 to 27 staples/sec

• Fastener Specifications

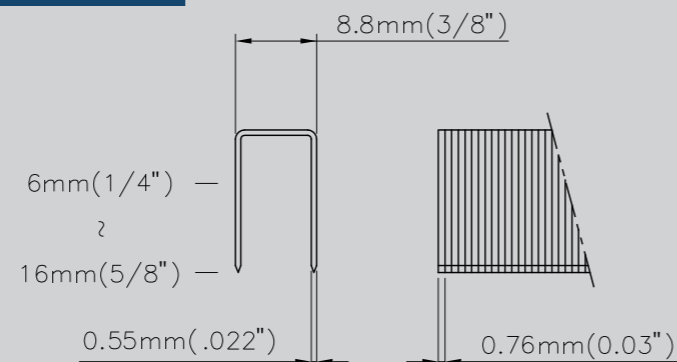

S71/16-22 _22GA. 3/8" Crown Stapler

- Dimensions
 - L: 8-15/32" (215mm) H: 5-11/16" (145mm) W: 1-11/16" (43mm)
- Weight - 2.16lbs(0.98kg)
- Fasteners
 - BEA : 71/71 Series - DUO FAST : 3118/3100
 - SENCO : SFW08/C - BOSTITCH : BA T401/BA-71
- Applications
 - Cabinets - Upholstered furniture
 - Automobile industry - Bedding industry
- Air Consumption
 - 0.17L/cycle, 6kg/cm²

• Fastener Specification

Type	22GA. 3/8" Crown Staples
Length	5/32" ~ 5/8" (4mm ~ 16mm)
Crown	3/8" (8.8mm)
Width x Thickness	.022" x .030" (0.55mmx0.76mm)
Load Capacity	190



S71/16-22 ALM _22GA. 3/8" Crown Double Length Magazine Auto Stapler

- Dimensions
 - L: 14" (356mm) H: 6-1/8" (155mm) W: 1-21/32" (42mm)
- Weight - 2.95lbs(1.35kg)
- Fasteners
 - BEA : 71/14-451AL
 - FASCO : F1B 7C-16AUT. L.M
- Applications
 - Insulation - Upholstering operations
 - Automotive vinyl roofs and interior trim
 - Molding and roofing felt - Cabinets
- Air Consumption
 - 0.18L/cycle, 6kg/cm²

• Fastener Specification

Type	22GA. 3/8" Crown Staples
Length	1/4" ~ 5/8" (6mm ~ 16mm)
Crown	3/8" (8.8mm)
Width x Thickness	.022" x .030" (0.55mmx0.76mm)
Load Capacity	330(MAX. 378)



S71/16-22 A _22GA. 3/8" Crown Auto Stapler

- **Dimensions**
 - L: 12-1/2" (233mm) H: 6-1/8" (155mm) W: 1-21/32" (42mm)
- **Weight** - 2.65lbs(1.2kg)
- **Fasteners**
 - BEA : 71/14-451AL
 - FASCO : 7C-16AUT
- **Applications**
 - Insulation - Upholstering operations
 - Automotive vinyl roofs and interior trim
 - Molding and roofing felt - Cabinets
- **Air Consumption**
 - 0.18L/cycle, 6kg/cm²
- **Fastener Specification**



Type	22GA. 3/8" Crown Staples
Length	1/4" ~ 5/8" (6mm ~ 16mm)
Crown	3/8" (8.8mm)
Width x Thickness	.022" x .030" (0.55mmx0.76mm)
Load Capacity	165(MAX. 185)

S80/16-20 A _20GA. 1/2" Crown Auto Stapler

- **Dimensions**
 - L: 12-1/2" (233mm) H: 6-1/8" (155mm) W: 1-21/32"(42mm)
- **Weight** - 2.47lbs(1.12kg)
- **Fasteners**
 - BEA : 380/14-450A
 - FASCO : F1B A80-16 AUT
- **Applications**
 - Insulation - Upholstering operations
 - Automotive vinyl roofs and interior trim
 - Molding and roofing felt
- **Air Consumption**
 - 0.18L/cycle, 6kg/cm²
- **Fastener Specification**



Type	20GA. 1/2" Crown Staples
Length	1/4" ~ 5/8" (6mm ~ 16mm)
Crown	1/2" (12.8mm)
Width x Thickness	.028" x .036" (0.71mm x 0.92mm)
Load Capacity	130(MAX. 150)

S80/16-20 _20GA. 1/2" Crown Stapler

- **Dimensions**
 - L: 8-15/32" (215mm) H: 5-11/16" (145mm) W: 1-11/16" (43mm)
- **Weight** - 2.13lbs(0.97kg)
- **Fasteners**
 - BEA : 380/80 Series
 - BOSTITCH : BA T400/BA-80
- **Applications**
 - Upholstered furniture
 - TV & stereo cabinets - Bedding industry
 - Automobile industry - Wicker & rattan furniture
- **Air Consumption**
 - 0.17L/cycle, 6kg/cm²
- **Fastener Specification**



Type	20GA. 1/2" Crown Staples
Length	5/32" ~ 5/8" (4mm ~ 16mm)
Crown	1/2" (12.8mm)
Width x Thickness	.028" x .036" (0.71mmx0.92mm)
Load Capacity	155

B635 _23GA. Cordless Pin Nailer

- **Dimensions**
 - L: 8-7/8" (226mm) H: 3-11/16" (93.8mm) W: 9-1/8" (231mm)
- **Weight** - 5.22lbs(2.37kg) (with 2Ah battery)
- **Fasteners**
 - MAX : TA20A Series
 - HITACHI : NT Series
- **Applications**
 - Interior Trim & Exterior Trim
 - Furniture Trim
 - Molding & Decorative Trim
- **Fastener Specification**



Type	23GA. Micro Pins
Length	5/8" ~ 1-3/8" (15mm ~ 35mm)
Width x Thickness	.025" x .025" (.64mm x .64mm)
Load Capacity	100

630R _23GA. 1-3/16" Micro Pinner

- Dimensions
 - L: 9-7/16" (240mm) H: 7-3/8" (188mm) W: 1-7/8" (48mm)
- Weight - 2.36lbs(1.07kg)
- Fasteners
 - MAX : NF235A/23-35
 - BOSTITCH : HP118K/PT1312
 - SENCO : FinishPro 11/CZ
- Applications
 - Cabinets - Finish and Trim
 - Trim - Mirror and Picture Frames
- Air Consumption
 - 0.21L/cycle, 6kg/cm²
- Fastener Specification



Type	23GA. Micro Pins
Length	3/8" ~ 1-3/16" (10mm ~ 30mm)
Width x Thickness	.025" x .025" (.64mm x .64mm)
Load Capacity	200

640S _23GA. 1-9/16" Micro Pinner

- Dimensions
 - L: 9-15/16" (252mm) H: 7-7/8" (200mm) W: 1-7/8" (47mm)
- Weight - 2.64lbs(1.20kg)
- Fasteners
 - MAX : NF235A/23-35
 - BOSTITCH : HP118K/PT1312
 - SENCO : FinishPro 10/CZ
- Applications
 - Cabinets - Finish and Trim
 - Trim - Mirror and Picture Frames
- Air Consumption
 - 0.23L/cycle, 6kg/cm²
- Fastener Specification



Type	23GA. Micro Pins
Length	5/8" ~ 1-9/16" (15mm ~ 40mm)
Width x Thickness	.025" x .025" (.64mm x .64mm)
Load Capacity	200

AP35RN _Air Punch

32/33

- Dimensions
 - L: 8-3/8" (214mm)
 - H: 8-15/32" (215mm)
 - W: 2-11/32" (60mm)
- Weight
 - 1.83lbs(0.83kg)
- Shank Diameter
 - Ø1.5 ~ Ø5.0mm
- Applications
 - Removing Nails
- Air Consumption
 - 0.56L/cycle, 6kg/cm²



AP64RN _Air Punch

- Dimensions
 - L: 10-13/16" (275mm)
 - H: 10-19/32" (269mm)
 - W: 3-15/32" (88mm)
- Weight
 - 3.75lbs(1.7kg)
- Shank Diameter
 - Ø3.5 ~ Ø6.0mm
- Applications
 - Removing Nails
- Air Consumption
 - 1.48L/cycle, 7kg/cm²



A large, empty rectangular box with a thin black border, occupying most of the page area. It is intended for writing notes or a memo.A large, empty rectangular box with a thin black border, occupying most of the page area. It is intended for writing notes or a memo.