

SPACERS, EXPANSION JOINTS AND PROFILES

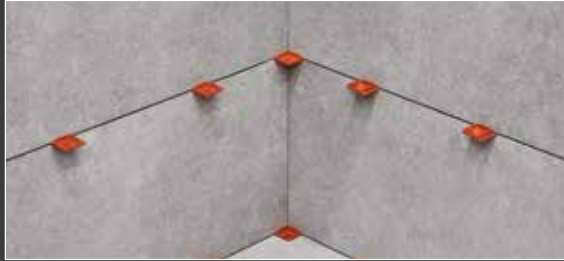

REMOVABLE AND REUSABLE DUAL SIZE (JOINT) SPACER

DOUBLE	R2
--------------	----

SPACERS FOR 20 mm THICKNESS TILES

SPACERS FOR 20 mm THICKNESS TILES	R3
---	----

3 IN-ONE TILE SHIM "ROTOCUNEO"

"ROTOCUNEO" FOR JOINTS FROM 2 mm UP TO 10 mm.....	R3
---	----

SPACERS FOR "+" AND "T" SETTING LAYOUT

10 mm	R4
9 mm	R4
8 mm	R4
7 mm	R4
6 mm	R5
5 mm	R5
4 mm	R5
3 mm	R6
2 mm	R6
1,5 mm	R6
1 mm	R6

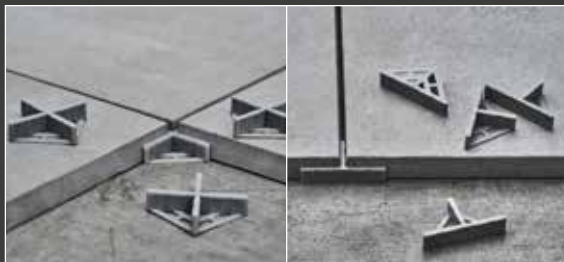

SPACERS FOR OCTAGONAL TILES, "CASSETTONATO"

AND LOZENGE, SPACERS FOR HEXAGONAL TILES,

SPACERS FOR PROVINCIAL - "PROVENZALE"

SPACERS FOR OCTAGONAL TILES, "CASSETTONATO" AND LOZENGE	R7
SPACERS FOR HEXAGONAL TILES	R7
SPACERS FOR PROVINCIAL - "PROVENZALE"	R7
SPACERS FOR SPECIAL FORMATS (RHOMBUS)	R7



WEDGES

BIG WEDGES	R7
SMALL WEDGES	R7

FLOATING FLOORS SUPPORTS

FLOATING FLOORS SUPPORTS	R7
--------------------------------	----



EXPANSION JOINTS AND PROFILES

EXPANSION JOINTS	R8
PVC TRANSITION PROFILES	R8

11 sizes (from 1 to 10 mm - 1/32" - 3/8") in 39 different models : here is our range of spacers. A line of spacers for the professional which can choose versions with different heights, with holes for the passage of the adhesive, with fins for easy removal or to avoid the outcrop if installing with the traditional "mud-med" method, or even with the unique "Lego" system, which allows to fit a spacer over the other to get the desired thickness. Of course, both for cross and "T" installation. In addition, three models (3 mm - 1/8" joint) for octagonal tile, "cassettonato", lozenge, hexagonal tiles, "provenzale" tiles and two models (2 mm - 3/32" joint) for special formats (rhombus). To complete the offer, shimming wedges are available in two sizes and "Rotocuneo", the new 3-in-one tile shim for adjustments from 2 mm (3/32") up to 10 mm (3/8"). Also expansion joints, profiles and floating floors supports and the new spacers designed for the laying of tiles with high thickness (20 mm - 3/4"), whose characteristics make them ideal for outdoor floors. Last, but not least, the removable and reusable dual size (joint) spacer "DOUBLE", available in two versions, each one designed to create two joints of different sizes (one model for joints of 1 and 3 mm - 1/32" and 1/8", one model for joints 2 and 5 mm - 3/32" and 3/16"). Designed to work on the sides of the tiles and flush to the floor as well as into corners. This is particularly helpful for wall covering.

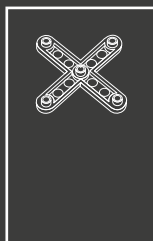

REMOVABLE AND REUSABLE DUAL SIZE (JOINT) SPACER

MADE IN ITALY



282D1-3C300
Rear view (flat facet)



282D1-3C300
Front view

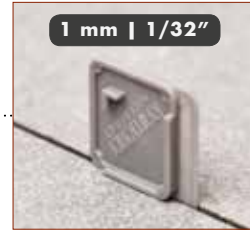

1 mm | 1/32"

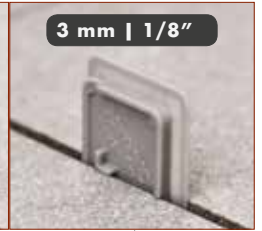

3 mm | 1/8"



282D2-5C300
Rear view (flat facet)



282D2-5C300
Front view



2 mm | 3/32"



5 mm | 3/16"

- Available in two versions: to create joint sized 1 and 3 mm - 1/32" and 1/8" (grey color); to create joints sized 2 and 5 mm - 3/32" and 3/16" (red color).
- Each DOUBLE is designed to create two joints of different sizes: two sides for one joint size, the other two for the other joint size. Therefore, DOUBLE is actually a "Dual-Size" removable (and reusable) spacer.
- The dual size (joint) spacer DOUBLE has been de-signed to be very easy to remove after use. This in accordance with regulations about correct ceramic tile installation such as the Italian UNI 11493-1.
- The removal and use do not damage the product therefore DOUBLE is reusable virtually forever.
- Its generous dimensions (37x37 mm | 1 1/2"x1 1/2") make very easy to grasp it both during insertion and, even more important, removal phase.
- The wide gap within joints sizes present on the same spacer makes it easy to recognize them.
- Thanks to the wide contact surface between tiles once in working position, DOUBLE ensures both

perfect joint size and parallelism of the tiles.

- DOUBLE is designed to work on the sides of the tiles (not into intersections) so to ensures the maximum effectiveness (especially on large format tiles).
- One of the two facets of DOUBLE is flat so to allow the product to be used flush to the floor as well as into corners. This is particularly helpful for wall covering.
- DOUBLE is made of plastic material which hinders the adhesion of the adhesive (thin-set) to the spacer.
- Double is proposed inside a practical resealable bucket for storing the product after use.

DOUBLE 1-3 mm (1/32" - 1/8") e 2-5 mm (3/32" - 3/16")

Part No.			Description	Joint	Color		
282D1-3C300	8050532000636	6	DOUBLE SPACER; joint 1 and 3 mm (1/32" - 1/8"). 300 pcs bucket.	1 e 3 mm 1/32" e 1/8"		58x20xh 27 cm 23"x8"x h 10 1/2"	5,5 Kg 12.1 lbs
282D2-5C300	8050532002432	6	DOUBLE SPACER; joint 2 and 5 mm (3/32" - 3/16"). 300 pcs bucket.	2 e 5 mm 3/32" e 3/16"			6,9 Kg 15.2 lbs



SPACERS, EXPANSION JOINTS AND PROFILES

SPACERS FOR 20 mm (3/4") THICKNESS TILES – JOINT 4 mm (5/32")

MADE IN ITALY

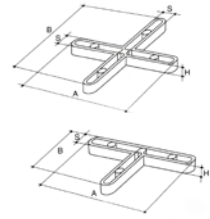
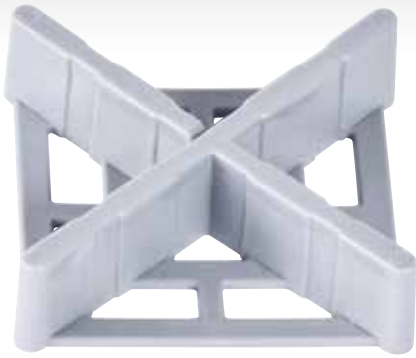

313+200		313+500	
S	A	B	H
4mm 5/32"	64mm 2 1/2"	64mm 2 1/2"	12mm 15/32"

313T200		313T500	
S	A	B	H
4mm 5/32"	64mm 2 1/2"	34mm 1 11/32"	12mm 15/32"

- Spacers for tiles/slabs with a thickness equal or higher than 20 mm (3/4").
- Available both "+" and "T" types.
- Perfect for outdoor floors laid both with adhesive or onto sand.
- Made of plastic material which is tested for being resistant even when subjected to bad weather conditions and thermal stress.

- Equipped with special wings, designed for preventing the rising of the spacer during the vibrator method.
- The special wings are also provided with specific openings with draining function.
- Spacer's height: 12 mm (1/2").

Part No.	Barcode	Type	Pieces	Box	Open	Upright	Down	Left	Right	Box	Weight	Weight	
313+200	8024648095268	+	200	-	•	-	•	-	•	•	8	9,7 Kg	21.4 lbs
313+500	8024648095275	+	500	-	•	-	•	-	•	•	3	9,2 Kg	20.3 lbs
313T200	8024648095282	T	200	-	•	-	•	-	•	•	12	11 Kg	24.3 lbs
313T500	8024648095299	T	500	-	•	-	•	-	•	•	5	11,4 Kg	25.1 lbs

59x30xh40 cm
23 5/8" x 11 7/8" x h 15 5/4"

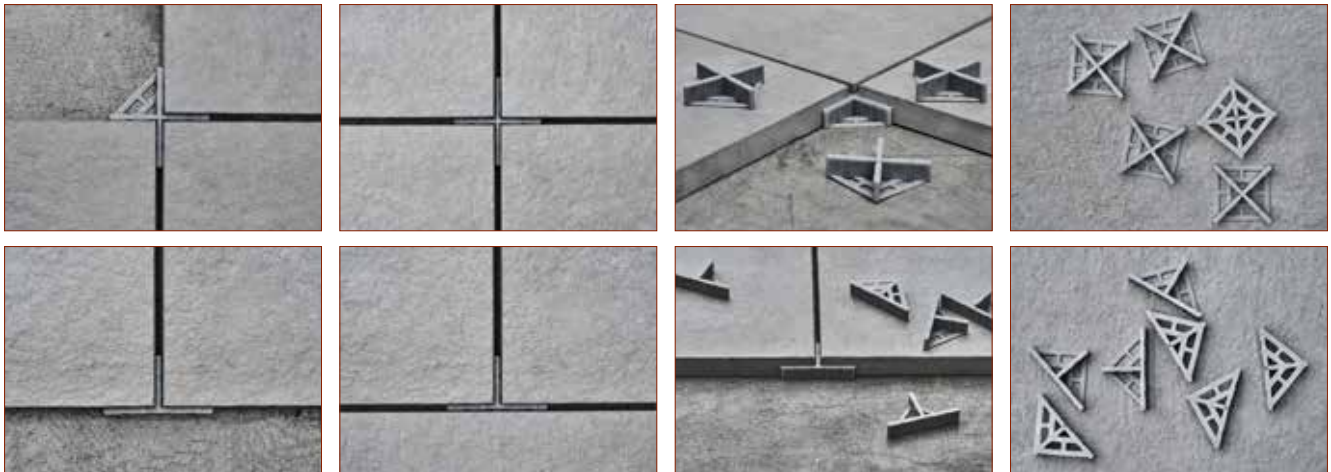

ROTOCUNEO - FROM 2 mm (3/32") UP TO 10 mm (3/8") JOINTS

NEW

MADE IN E.U.



- 3 in 1 tile shim: 2 spiral-shaped wedges (lateral ones) + 1 wedge (middle one).
- For joint adjustments from 2 to 10 mm.

- In the removal phase, it avoids the chipping of the tile / slab.
- Recommended for extremely delicate tiles / slabs.

Part No.	Barcode	Box	Description	Joint	Weight	Weight	Box	Box	Weight	Weight
162RC30	8050532006775	27	30 Kits RotocunEO bucket (60 spiral-shaped wedges + 30 wedges)	from 2 to 10 mm from 3/32" up to 3/8"	220 gr	0.5 oz	40x60xh 25 cm	15 3/4"x23 5/8"xh 10"	7 Kg	15.4 oz

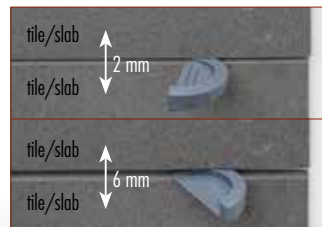
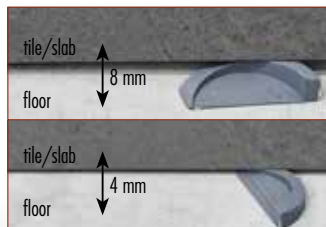

SPACERS 10 mm – 3/8"

MADE IN ITALY



193+1000		204+200	
S	A	B	H
10mm	40mm	40mm	7mm
3/8"	1 9/16"	1 9/16"	9/32"



204 R200			
S	A	B	H
10mm	50mm	50mm	13mm
3/8"	2"	2"	17/32"



193T1000		204T200	
S	A	B	H
10mm	40mm	25mm	7mm
3/8"	1 9/16"	1"	9/32"



204T200A			
S	A	B	H
10mm	50mm	30mm	13mm
3/8"	2"	1 3/16"	17/32"

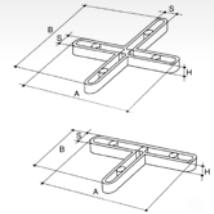

Part No.	Barcode	Type	Pieces	Box	Bag	Upright	Arch	Down	Black	Up	Box	Box	Weight	
193+1000	8024648001306	+	1000	•	-	•	-	-	•	-	12	62x42x54 cm	24 3/8"x16 1/2"xh 21 1/4"	26,5 Kg 58.4 lbs
204+200	8024648001641	+	200	-	•	•	-	-	•	-	25	48x46x28 cm	18 7/8"x18 1/8"xh 11"	10,6 Kg 23.3 lbs
204R200	8024648001634	+	200	-	•	-	-	-	-	•	10	48x46x28 cm	18 7/8"x18 1/8"xh 11"	9,2 Kg 20.3 lbs
193T1000	8024648001313	+	1000	•	-	•	-	-	•	-	12	62x42x54 cm	24 3/8"x16 1/2"xh 21 1/4"	20,2 Kg 44.5 lbs
204T200	8024648001658	+	200	-	•	•	-	-	•	-	25	48x35x28 cm	18 7/8"x13 3/4"xh 11"	7,4 Kg 16.3 lbs
204T200A	8024648001665	+	200	-	•	-	-	-	•	-	10	48x35x28 cm	18 7/8"x13 3/4"xh 11"	6,6 Kg 14.5 lbs

SPACERS 9 mm – 11/32"



129+1000		128+200	
S	A	B	H
9mm	50mm	50mm	7mm
11/32"	2"	2"	9/32"



129T1000		128T200	
S	A	B	H
9mm	50mm	30mm	7mm
11/32"	2"	1 3/16"	9/32"

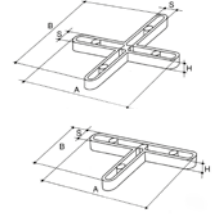

Part No.	Barcode	Type	Pieces	Box	Bag	Upright	Arch	Down	Black	Up	Box	Box	Weight	
129+1000	8024648001337	+	1000	•	-	-	•	•	-	-	12	62x42x54 cm	24 3/8"x16 1/2"xh 21 1/4"	32,2 Kg 70.9 lbs
128+200	8024648001672	+	200	-	•	-	•	-	-	-	25	48x46x28 cm	18 7/8"x18 1/8"xh 11"	13,6 Kg 29.9 lbs
129T1000	8024648001344	+	1000	•	-	-	•	-	-	-	12	62x42x54 cm	24 3/8"x16 1/2"xh 21 1/4"	26,7 Kg 58.8 lbs
128T200	8024648001689	+	200	-	•	-	•	-	-	-	25	48x35x28 cm	18 7/8"x13 3/4"xh 11"	10,6 Kg 23.3 lbs

SPACERS 8 mm – 5/16"



372+1000		376+200	
S	A	B	H
8mm	40mm	40mm	7mm
5/16"	1 9/16"	1 9/16"	9/32"



372T1000		376T200	
S	A	B	H
8mm	40mm	25mm	7mm
5/16"	1 9/16"	1"	9/32"

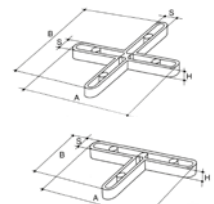

Part No.	Barcode	Type	Pieces	Box	Bag	Upright	Arch	Down	Black	Up	Box	Box	Weight	
372+1000	8024648001351	+	1000	•	-	•	-	-	•	-	12	62x42x54 cm	24 3/8"x16 1/2"xh 21 1/4"	23,1 Kg 50.9 lbs
376+200	8024648001696	+	200	-	•	•	-	-	•	-	25	48x46x28 cm	18 7/8"x18 1/8"xh 11"	9,6 Kg 21.2 lbs
372T1000	8024648001368	+	1000	•	-	•	-	-	•	-	8	46x41x32 cm	18 1/8"x16 1/8"xh 12 5/8"	12,7 Kg 27.9 lbs
376T200	8024648001702	+	200	-	•	•	-	-	•	-	25	48x35x28 cm	18 7/8"x13 3/4"xh 11"	7,6 Kg 16.7 lbs

SPACERS 7 mm – 9/32"



152+1000E		151+200E	
S	A	B	H
7mm	40mm	40mm	7mm
9/32"	1 9/16"	1 9/16"	9/32"



152+1000L		151+200L	
S	A	B	H
7mm	40mm	40mm	5mm
9/32"	1 9/16"	1 9/16"	3/16"



152T1000E		151T200E	
S	A	B	H
7mm	40mm	25mm	7mm
9/32"	1 9/16"	1"	9/32"

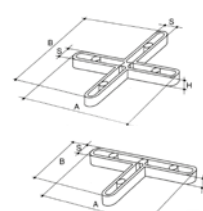

Part No.	Barcode	Type	Pieces	Box	Bag	Upright	Arch	Down	Black	Up	Box	Box	Weight	
152+1000E	8024648001375	+	1000	•	-	•	-	-	•	-	12	62x42x54 cm	24 3/8"x16 1/2"xh 21 1/4"	26 Kg 57.3 lbs
151+200E	8024648001719	+	200	-	•	•	-	-	•	-	25	48x46x28 cm	18 7/8"x18 1/8"xh 11"	10,6 Kg 23.4 lbs
152+1000L	8024648001382	+	1000	•	-	•	-	-	•	-	16	62x42x45 cm	24 3/8"x16 1/2"xh 21 1/4"	18,4 Kg 40.5 lbs
151+200L	8024648001726	+	200	-	•	•	-	-	•	-	25	48x35x28 cm	18 7/8"x13 3/4"xh 11"	5,6 Kg 12.3 lbs
152T1000E	8024648001399	+	1000	•	-	•	-	-	•	-	8	46x41x32 cm	18 1/8"x16 1/8"xh 12 5/8"	13,3 Kg 29.3 lbs
151T200E	8024648001733	+	200	-	•	•	-	-	•	-	30	48x35x28 cm	18 7/8"x13 3/4"xh 11"	9,6 Kg 21.2 lbs



SPACERS 6 mm – 1/4"

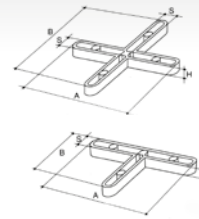

MADE IN ITALY

154+1000		153+200	
S	A	B	H
6mm	50mm	50mm	7mm
1/4"	2"	2"	9/32"

154+200		153T200	
S	A	B	H
6mm	50mm	28mm	7mm
1/4"	2"	1 7/64"	9/32"

Part No.	Barcode	Type	Pieces	Box	Envelope	Upright	Arch	Down	Up	Box	Box	Box
154+1000	8024648001405	+	1000	•	-	-	•	•	-	-	12	62x42xh 54 cm
153+200	8024648001740	+	200	-	•	-	•	•	-	-	25	48x46xh 28 cm
154T1000	8024648001412	+	1000	•	-	-	•	•	-	-	8	46x41xh 32 cm
153T200	8024648001757	+	200	-	•	-	•	•	-	-	30	48x35xh 28 cm

SPACERS 5 mm – 3/16"

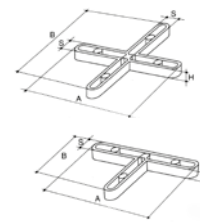

156+1000		155+200	
S	A	B	H
5mm	50mm	50mm	6mm
3/16"	2"	2"	1/4"

156+1000L		155+200L	
S	A	B	H
5mm	40mm	40mm	5mm
3/16"	1 9/16"	1 9/16"	3/16"

156R1000S		155R200	
S	A	B	H
5mm	50mm	50mm	6mm
3/16"	2"	2"	9/32"

156T1000		155T200	
S	A	B	H
5mm	35mm	28mm	6mm
3/16"	1 3/8"	1 7/64"	1/4"

156T1000E		155T200E	
S	A	B	H
5mm	35mm	28mm	6mm
3/16"	1 3/8"	1 7/64"	1/4"

Part No.	Barcode	Type	Pieces	Box	Envelope	Upright	Arch	Down	Up	Box	Box	Box
156+1000	8024648001450	+	1000	•	-	-	•	•	-	-	12	62x42xh 54 cm
155+200	8024648001795	+	200	-	•	-	•	•	-	-	25	48x46xh 28 cm
156+1000L	8024648001436	+	1000	•	-	-	•	•	-	-	16	62x42xh 45 cm
155+200L	8024648001771	+	200	-	•	-	•	•	-	-	25	48x35xh 28 cm
156R1000S	8024648008329	+	1000	•	-	-	•	•	-	-	10	62x42xh 45 cm
155R200	8024648001764	+	200	-	•	-	•	•	-	-	20	48x46xh 28 cm
156T1000	8024648001467	+	1000	•	-	-	•	•	-	-	8	46x41xh 32 cm
155T200	8024648001801	+	200	-	•	-	•	•	-	-	30	48x35xh 28 cm
156T1000E	8024648001443	+	1000	•	-	-	•	•	-	-	16	46x41xh 32 cm
155T200E	8024648001788	+	200	-	•	-	•	•	-	-	40	32x32xh 28 cm

SPACERS 4 mm – 5/32"

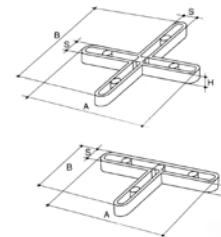

158+1000		157+200	
S	A	B	H
4mm	38mm	38mm	4mm
5/32"	1 31/64"	1 31/64"	5/32"

158R1000		157R200	
S	A	B	H
4mm	30mm	30mm	6mm
5/32"	1 3/16"	1 3/16"	1/4"

158T1000		157T200	
S	A	B	H
4mm	38mm	20mm	4mm
5/32"	1 31/64"	25/32"	5/32"

Part No.	Barcode	Type	Pieces	Box	Envelope	Upright	Arch	Down	Up	Box	Box	Box
158+1000	8024648001481	+	1000	•	-	-	•	•	-	-	24	62x42xh 45 cm
157+200	8024648001825	+	200	-	•	-	•	•	-	-	50	48x35xh 28 cm
158R1000	8024648008435	+	1000	•	-	-	•	•	-	-	16	62x42xh 45 cm
157R200	8024648001818	+	200	-	•	-	•	•	-	-	25	32x32xh 28 cm
158T1000	8024648001498	+	1000	•	-	-	•	•	-	-	16	46x41xh 32 cm
157T200	8024648001832	+	200	-	•	-	•	•	-	-	40	32x32xh 28 cm

SPACERS, EXPANSION JOINTS AND PROFILES



SPACERS 3 mm - 1/8"

MADE IN ITALY



160+1000		159+200	
S	A	B	H
3mm	38mm	38mm	3,5mm
1/8"	1 31/64"	1 31/64"	9/64"

160+1000E		159+200E	
S	A	B	H
3mm	28mm	28mm	3mm
1/8"	1 7/64"	1 7/64"	1/8"

160+T1000		159+T200	
S	A	B	H
3mm	38mm	38mm	8mm
1/8"	1 31/64"	1 31/64"	5/16"

160R1000		159R200	
S	A	B	H
3mm	38mm	38mm	3,5mm
1/8"	1 31/64"	1 31/64"	9/64"

160+1000A		159+200A	
S	A	B	H
3mm	38mm	38mm	8mm
1/8"	1 31/64"	1 31/64"	5/16"

160T1000		159T200	
S	A	B	H
3mm	38mm	20mm	3,5mm
1/8"	1 31/64"	25/32"	9/32"

Part No.	Barcode	Type	Pieces	Box	Roll	Upright	Arch	Triangle	Square	Circle	Star	Box	Box	Box	
160+1000	8024648001528	+	1000	•	-	•	-	-	•	-	-	24	62x42x45 cm	24 3/8"x16 1/2"x17 3/4"	17,6 Kg 38.8 lbs
159+200	8024648001863	+	200	-	•	•	-	-	•	-	-	50	48x35x28 cm	18 7/8"x13 3/4"x11"	6,6 Kg 14.5 lbs
160+1000E	8024648001542	+	1000	•	-	•	-	-	•	-	-	32	42x42x40 cm	16 1/2"x16 1/2"x15 3/4"	14 Kg 30.9 lbs
159+200E	8024648001887	+	200	-	•	•	-	-	•	-	-	60	32x32x28 cm	12 9/16"x12 9/16"x11"	4,9 Kg 10.8 lbs
160+T1000	8024648008831	+	1000	•	-	•	-	-	•	-	-	16	62x42x45 cm	24 3/8"x16 1/2"x17 3/4"	19,6 Kg 43.2 lbs
159+T200	8024648008534	+	200	-	•	•	-	-	•	-	-	30	48x35x28 cm	18 7/8"x13 3/4"x11"	6,6 Kg 14.5 lbs
160R1000	8024648008572	+	1000	•	-	•	-	-	•	-	-	16	62x42x45 cm	24 3/8"x16 1/2"x17 3/4"	14,3 Kg 31.5 lbs
159R200	8024648001856	+	200	-	•	•	-	-	•	-	-	40	48x35x28 cm	18 7/8"x13 3/4"x11"	6,6 Kg 14.5 lbs
160+1000A	8024648005960	+	1000	-	•	•	-	-	•	-	-	16	62x42x45 cm	24 3/8"x16 1/2"x17 3/4"	18,8 Kg 41.4 lbs
159+200A	8024648005977	+	200	-	•	•	-	-	•	-	-	30	48x35x28 cm	18 7/8"x13 3/4"x11"	7,5 Kg 16.5 lbs
160T1000	8024648001535	+	1000	•	-	•	-	-	•	-	-	16	46x41x32 cm	18 1/8"x16 1/8"x12 5/8"	8,5 Kg 18.7 lbs
159T200	8024648001870	+	200	-	•	•	-	-	•	-	-	40	32x32x28 cm	12 9/16"x12 9/16"x11"	4 Kg 8.8 lbs

SPACERS 2 mm - 3/32"



133+1000		132+200	
S	A	B	H
2mm	28mm	28mm	2,8mm
3/32"	1 7/64"	1 7/64"	7/64"

133+1000A		132+200A	
S	A	B	H
2mm	28mm	28mm	7mm
3/32"	1 7/64"	1 7/64"	9/32"

133R1000		132R200	
S	A	B	H
2mm	28mm	28mm	2,8mm
3/32"	1 7/64"	1 7/64"	7/64"

133R1000A		132R200A	
S	A	B	H
2mm	28mm	28mm	7mm
3/32"	1 7/64"	1 7/64"	9/32"

133T1000		132T200	
S	A	B	H
2mm	28mm	16mm	2,8mm
3/32"	1 7/64"	5/8"	7/64"

Part No.	Barcode	Type	Pieces	Box	Roll	Upright	Arch	Triangle	Square	Circle	Star	Box	Box	Box	
133+1000	8024648001566	+	1000	•	-	-	•	-	•	-	-	32	42x42x40 cm	16 1/2"x16 1/2"x15 3/4"	11,2 Kg 24.7 lbs
132+200	8024648001900	+	200	-	•	-	•	-	•	-	-	50	32x32x28 cm	12 9/16"x12 9/16"x11"	3,4 Kg 7.5 lbs
133+1000A	8024648008749	+	1000	-	•	-	•	-	•	-	-	16	46x41x32 cm	18 1/8"x16 1/8"x12 5/8"	11,4 Kg 25 lbs
132+200A	8024648004604	+	200	-	•	-	•	-	•	-	-	30	32x32x28 cm	12 9/16"x12 9/16"x11"	4,2 Kg 9.3 lbs
133R1000	8024648008671	+	1000	•	-	-	•	-	•	-	-	16	62x42x45 cm	24 3/8"x16 1/2"x17 3/4"	8,1 Kg 17.8 lbs
132R200	8024648001894	+	200	-	•	-	•	-	•	-	-	40	32x32x28 cm	12 9/16"x12 9/16"x11"	15,6 Kg 34.4 lbs
133R1000A	8024648014030	+	1000	•	-	-	•	-	•	-	-	16	62x42x45 cm	24 3/8"x16 1/2"x17 3/4"	11,2 Kg 24.6 lbs
132R200A	8024648015365	+	200	-	•	-	•	-	•	-	-	30	32x32x28 cm	12 9/16"x12 9/16"x11"	4,5 Kg 9.8 lbs
133T1000	8024648001573	+	1000	•	-	-	•	-	•	-	-	32	42x42x40 cm	16 1/2"x16 1/2"x15 3/4"	8,9 Kg 19.6 lbs
132T200	8024648001917	+	200	-	•	-	•	-	•	-	-	50	32x32x28 cm	12 9/16"x12 9/16"x11"	2,4 Kg 5.3 lbs
132T200A	8024648004611	+	200	-	•	-	•	-	•	-	-	40	32x32x28 cm	12 9/16"x12 9/16"x11"	2,4 Kg 5.3 lbs

SPACERS 1,5 mm - 1/16"



131+1000		131+200	
S	A	B	H
1,5mm	33mm	33mm	5mm
1/16"	1 5/16"	1 5/16"	3/16"

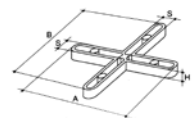

Part No.	Barcode	Type	Pieces	Box	Roll	Upright	Arch	Triangle	Square	Circle	Star	Box	Box	Box	
131+1000	8024648060808	+	1000	•	-	-	•	-	•	-	-	16	62x42x45 cm	24 1/2"x16 1/2"x17 3/4"	8 Kg 17.6 lbs
131+200	8024648060815	+	200	-	•	-	•	-	•	-	-	30	46x41x32 cm	18 "x16 "x12 1/2"	3 Kg 6.6 lbs

SPACERS 1 mm - 1/32"



143+1000		143+200	
S	A	B	H
1mm	28mm	28mm	3mm
1/32"	1 7/64"	1 7/64"	1/8"

143T1000		143T200	
S	A	B	H
1mm	32mm	16mm	4mm
1/32"	1 3/16"	5/8"	5/32"

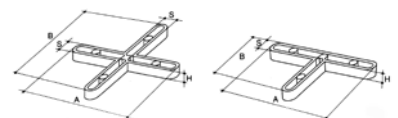

Part No.	Barcode	Type	Pieces	Box	Roll	Upright	Arch	Triangle	Square	Circle	Star	Box	Box	Box	
143+1000	8024648004581	+	1000	•	-	-	•	-	•	-	-	32	42x42x40 cm	16 1/2"x16 1/2"x15 3/4"	7 Kg 15.4 lbs
143+200	8024648004628	+	200	-	•	-	•	-	•	-	-	50	32x32x28 cm	12 9/16"x12 9/16"x11"	1,9 Kg 4.2 lbs
143T1000	8024648017796	+	1000	•	-	-	•	-	•	-	-	32	42x42x40 cm	16 1/2"x16 1/2"x15 3/4"	7 Kg 15.4 lbs
143T200	8024648017802	+	200	-	•	-	•	-	•	-	-	50	32x32x28 cm	12 9/16"x12 9/16"x11"	1,9 Kg 4.2 lbs





163P1000		162P200	
S	A	B	H
-	28mm 1 7/64"	10mm 13/32"	6mm 1/4"



163G1000		162G200	
S	A	B	H
-	40mm 1 9/16"	9mm 11/32"	8mm 5/16"



MADE IN ITALY

Part No.	Barcode	Type	Pieces	Box	Box	Box	Box	Box	Box	Box	Box	Box	Box	Box	Box	Box	Box	Box
163P1000	8024648001627	▶	1000	•	-	-	•	-	•	-	32	42x42xh40 cm	16 1/2"x16 1/2"xh 15 3/4"	18,2 Kg	40.1 lbs			
162P200	8024648001962	▶	200	-	•	-	•	-	•	-	50	32x32xh28 cm	12 9/16"x12 9/16"xh 11"	5,4 Kg	11.9 lbs			
163G1000	8024648001610	▶	1000	-	•	-	•	-	•	-	18	62x42xh45 cm	24 3/8"x16 1/2"xh 17 3/4"	20,5 Kg	45.1 lbs			
162G200	8024648001955	▶	200	-	•	-	•	-	•	-	25	32x32xh28 cm	12 9/16"x12 9/16"xh 11"	4,2 Kg	9.3 lbs			

SPACERS FOR OCTAGONAL TILES, "CASSETTONATO" AND LOZENGE (3 mm - 1/8")



161Y200			
S	A	B	H
3mm 1/8"	-	-	6mm 1/4"

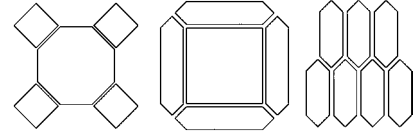
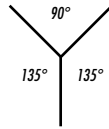

Part No.	Barcode	Type	Pieces	Box	Box	Box	Box	Box	Box	Box	Box	Box	Box	Box	Box	Box	Box	Box
161Y200	8024648001924	Y	200	-	•	-	•	-	•	-	40	32x32xh 28 cm	12 9/16"x12 9/16"xh 11"	3,6 Kg	7.9 lbs			

SPACERS FOR HEXAGONAL TILES (3 mm - 1/8")



161E200			
S	A	B	H
3mm 1/8"	-	-	5mm 6/16"

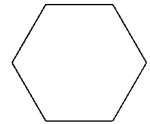
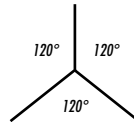

Part No.	Barcode	Type	Pieces	Box	Box	Box	Box	Box	Box	Box	Box	Box	Box	Box	Box	Box	Box	Box
161E200	8024648001931	Y	200	-	•	-	•	-	•	-	40	32x32xh 28 cm	12 9/16"x12 9/16"xh 11"	4,4 Kg	9.7 lbs			

SPACERS FOR SPECIAL FORMATS - RHOMBUS - (2 mm - 3/32")



161R200			
S	A	B	H
2mm 3/32"	-	-	3,5mm 9/64"

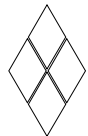

Part No.	Barcode	Type	Pieces	Box	Box	Box	Box	Box	Box	Box	Box	Box	Box	Box	Box	Box	Box	Box
161R200	8050532004184	X	200	-	•	-	•	-	•	-	40	32x32xh 28 cm	12 9/16"x12 9/16"xh 11"	3,7 Kg	8.1 lbs			

SPACERS FOR SPECIAL FORMATS - RHOMBUS - (2 mm - 3/32")



161Y200G4			
S	A	B	H
2mm 3/32"	-	-	3,5mm 9/64"

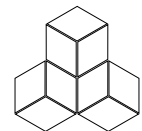
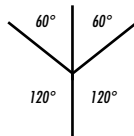

Part No.	Barcode	Type	Pieces	Box	Box	Box	Box	Box	Box	Box	Box	Box	Box	Box	Box	Box	Box	Box
161Y200G4	8050532007093	Y	200	-	•	-	•	-	•	-	40	32x32xh 28 cm	12 9/16"x12 9/16"xh 11"	3,6 Kg	7.9 lbs			

SPACERS FOR PROVINCIAL - "PROVENZALE" (3 mm - 1/8")



161P200			
S	A	B	H
3mm 1/8"	-	-	6mm 1/4"

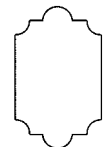

Part No.	Barcode	Type	Pieces	Box	Box	Box	Box	Box	Box	Box	Box	Box	Box	Box	Box	Box	Box	Box
161P200	8024648001948	T	200	-	•	-	•	-	•	-	40	32x32xh 28 cm	12 9/16"x12 9/16"xh 11"	4,4 Kg	9.7 lbs			

FLOATING FLOORS SUPPORTS



312P300		
S	O	H
4mm 19/16"	150mm 5 9/16"	6mm 11/16"

Part No.	Barcode	Type	Pieces	Box	Box	Box	Box	Box	Box	Box	Box	Box	Box	Box	Box	Box	Box	Box
312P300	8024648009845	⊙	-	-	-	-	-	-	-	-	300	65x45xh 45 cm	25 9/16"x17 3/4"xh 17 3/4"	27,4 Kg	60.4 lbs			



EXPANSION JOINTS AND PROFILES

MADE IN ITALY

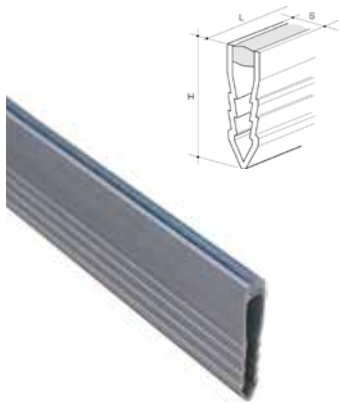

401

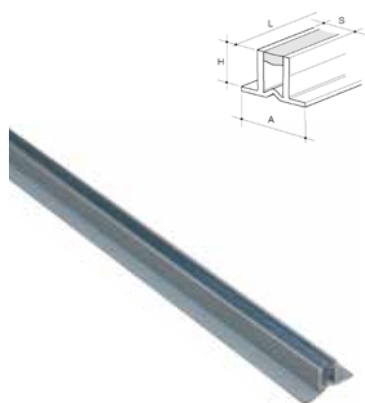

400



404/405/406

PACKAGE



CARTON BOX

EXPANSION JOINTS FOR THIN-SET ADHESIVE

Part No.	Barcode	Box Qty	Description	COLOR		S	H	Profile	Qtà totale	Box Dimensions	Weight
				External	Internal						
400 7X8G	8024648001993	40	Raiflex joint	grey	clear	8 mm 5/16"	7 mm 9/32"	250 cm 8' 2 1/2"	100 m 328'	254x12xh 9 cm 100"x4 3/4"xh 3 1/2"	8,3 Kg 18.3 lbs
400 9X8G	8024648002006	40	Raiflex joint	grey	clear	8 mm 5/16"	9 mm 23/64"	250 cm 8' 2 1/2"	100 m 328'	254x12xh 9 cm 100"x4 3/4"xh 3 1/2"	11,5 Kg 25.3 lbs
400 11X8G	8024648002013	40	Raiflex joint	grey	clear	8 mm 5/16"	11 mm 7/16"	250 cm 8' 2 1/2"	100 m 328'	254x12xh 9 cm 100"x4 3/4"xh 3 1/2"	14,7 Kg 32.4 lbs
400 13X8G	8024648002020	40	Raiflex joint	grey	clear	8 mm 5/16"	13 mm 33/64"	250 cm 8' 2 1/2"	100 m 328'	254x12xh 9 cm 100"x4 3/4"xh 3 1/2"	17,9 Kg 39.4 lbs
400 15X8G	8024648002037	40	Raiflex joint	grey	clear	8 mm 5/16"	15 mm 19/32"	250 cm 8' 2 1/2"	100 m 328'	254x12xh 9 cm 100"x4 3/4"xh 3 1/2"	21,1 Kg 6.5 lbs
400 20X8GG	8024648095732	40	Raiflex joint	light grey	light grey	8 mm 5/16"	19 mm 3/4"	250 cm 8' 2 1/2"	100 m 328'	254x16xh 9 cm 100"x6 1/4"xh 3 1/2"	16 Kg 35.3 lbs

EXPANSION JOINTS FOR MORTAR / MUD

Part No.	Barcode	Box Qty	Description	COLOR		S	H	Profile	Total Qty	Box Dimensions	Weight
				External	Internal						
401 23X8G	8024648002112	40	Raiflex joint	grey	clear	8 mm 5/16"	25 mm 31/32"	250 cm 8' 2 1/2"	100 m 328'	254x12xh 9 cm 100"x4 3/4"xh 3 1/2"	12,9 Kg 28.4 lbs
401 35X8G	8024648002105	40	Raiflex joint	grey	clear	8 mm 5/16"	35 mm 1 3/8"	250 cm 8' 2 1/2"	100 m 328'	254x16xh 9 cm 100"x6 1/4"xh 3 1/2"	22,5 Kg 49.6 lbs

PVC TRANSITION PROFILES

Part No.	Barcode	Box Qty	Description	COLOR	H	Profile	Total Qty	Box Dimensions	Weight
404TRIM6B	8024648002303	100	Jolly PVC	white	6 mm	250 cm	250 m	254x13xh 9 cm	13,3 Kg
404TRIM6G	8024648002310	100	Jolly PVC	grey	15/64"	250 cm	820' 2 1/2"	100"x5 1/16"xh 3 1/2"	29,3 lbs
405TRIM8B	8024648002334	80	Jolly PVC	white	8 mm	250 cm	200 m	254x13xh 9 cm	13,9 Kg
405TRIM8G	8024648002341	80	Jolly PVC	grey	5/16"	250 cm	656' 2"	100"x5 1/16"xh 3 1/2"	30,6 lbs
406TRIM10B	8024648002365	50	Jolly PVC	white	10 mm	250 cm	125 m	254x13xh 9 cm	10,8 Kg
406TRIM10G	8024648002372	50	Jolly PVC	grey	13/32"	250 cm	410' 1 1/4"	100"x5 1/16"xh 3 1/2"	23,8 lbs

SPACERS, EXPANSION JOINTS AND PROFILES



TOOLS FOR LARGE FORMAT TILES



CUTTING SYSTEM

RAIZOR: CUTTING GUIDES	S2
ACCESSORIES AND SPARE PARTS FOR RAIZOR	S3
POWER RAIZOR: MULTI-ANGLE CUTTING UNIT WITH ANGLE GRINDER.....	S4
ACCESSORIES FOR POWER RAIZOR	S5

CUTTING SYSTEM FREE-CUT

FREE-CUT: CUTTING GUIDES	S6
FREE-FLEX 90° AND 35°/55°: CUTTING UNIT WITH ANGLE GRINDER.....	S7
SAGOMACOSTE: PROFILING DEVICE FOR CREATING 1/2 BULLNOSE...S7	

MODULAR WORKING BENCHES

BM180 ^{PLUS} : ADJUSTABLE WIDTH (100-150 cm) MODULAR BENCH..S8	
BM180 ^{MkII} : MODULAR WORKING BENCH	S9
EXTENSION FOR BENCH BM180 ^{MkI}	S10
TILE-SUPPORT CYLINDERS	S11
SIDE PROFILES FOR SCORING AND CUT.....	S11
OTHER ACCESSORIES FOR BM180 ^{MkII}	S12

HANDLING SYSTEMS

EASY-MOVE ^{MkII} (VACUUM SUCTION CUPS WITH VACUUM GAUGE) ..S13	
EASY-MOVE ^{MkII} (VACUUM SUCTION CUPS)	S14
EASY-MOVE ^{MkII} (DOUBLE SUCTION CUPS)	S15
ACCESSORIES FOR EASY-MOVE ^{MkIII}	S16

MODULAR TROLLEY

CAM ADV: MODULAR TROLLEY	S17
--------------------------------	-----

VIBRATOR FOR LARGE FORMAT TILES

VOLPINO: COMPACT VIBRATOR	S18
---------------------------------	-----

OTHER TOOLS FOR BIG TILES/SLABS

CLOSER: DEVICE TO ACCOST TILES/SLABS	S19
RUBBER ANTI-BOUNCING TILE BEATER.....	S19
DIAMOND PADS FOR EDGE ANGLE GRINDER.....	S19

DEVICE TO PERFORM CIRCULAR CUTS

KOMPASS: DEVICE TO PERFORM CIRCULAR CUTS.....	S20
---	-----

DEVIVE FOR CREATING STEPS AND COUNTERTOPS

TIP TOP : FACE-UP MITER-CLAMPING-DEVICE FOR STAIRS AND COUNTERTOPS OF ANY LENGTH	S21
90° GLUING KIT	S22

The widest range of equipment ideal for the most innovative ceramic tiles slabs. With both RAIZOR and FREE-CUT rails, a perfect cut can be performed on slabs up to 447cm long. Furthermore, with the additional angle grinder support units POWER RAIZOR and FREE-FLEX, any type of cut can be performed. These angle grinder support units allow blade cuts such as miter cut at 45°, straight cut at 90°, as well as 180° to perform both incision on the side of the slab (slot) and to make a half-bullnose shape.

POWER RAIZOR allows to contain the dust during cutting with two special dedicated ACCESSORIES FORes, one of which does involve water.

The EASY-MOVE ^{MkIII} frame is the ideal handling solution suitable for any slab surface: from glossy to textured. The modular CAM ADV cart is the perfect solution to transport any slab, extremely useful to back-butter slabs with thinset adhesive.

The BM180 ^{MkII} and BM180 ^{PLUS} modular benches provide an optimum working table for slabs of any size and at the same time are easily transportable.

Of particular importance, the PLUS version allows to widen the bench width from 100 to 150 cm without the need of additional extensions.

To get our range ever wider, specific equipment to install slabs have been developed: the VOLPINO vibrator and our rubber tile beater are extremely useful to help any air pocket to escape from underneath the slab and prevent potential cracking, the CLOSER device to bring slab near to each other after being layed down on thinset mortar, the KOMPASS to perform circular score & snap cuts, a wide range of diamond pads to finish edges after cut.

Last but not least two devices for 90° gluing to make tops and steps on slabs of any length.

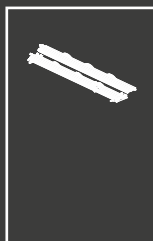

RAIZOR – CUTTING SYSTEM FOR LARGE FORMAT TILES



MADE IN ITALY



VERGINE ANTIMACCHIA STAIN FREE SECTION OFF

433CRR



PACKAGE



- Cutting system for large format tiles up to 332 cm - 10.9 ft. (447 cm - 14.7 ft. with optional extension), lightweight (9 Kg - 19.8 lbs) and easy to transport.
- RAIZOR is composed by:
 - two connectable guides with cutting length of 160 cm (5.2 ft.) each (332 cm - 10.9 ft. when combined);
 - die-cast cutting unit provided with wolfram carbide wheel Ø 16 mm (5/8") and pin (pin rotates on bearings);
 - cutting-off pliers for tiles/slabs with thickness from 3 to 6 mm (1/8" - 1/4");
 - everything packed in a padded bag with shoulder-straps and provided with inside modular compartments and pocket.
- The resistant padded bag protects the product and allow to carry it easily. It has adjustable compartments and inside pocket for placing personal belongings or work tools.
- Guides are made of sturdy aluminum extruded profiles, each one with 3 stain-free suction cups Ø 88 mm (3 1/2") - 6 suction cups in total.
- The suction cups, extremely useful while measuring the size of the cut to be made, prevent the cutting guide to move during the scoring, ensuring the maximum precision. Also, they prevent the cutting guide to overturn, no matter how much pressure is applied during the scoring: this allows to effectively score even high thickness tiles.
- The suction cups' handles perform a 180° movement in order not to interfere with the cutting unit.
- The cutting unit is made of die cast aluminum and runs onto the guide thanks to 3 polyoxymethylene (wearing-resistant material) wheels; each equipped with two internal bearings. It is provided with fine adjustment systems (factory-calibrated) allowing the perfect coupling of the cutting unit with the guide. This allows both to eliminates any kind of play and to perfectly align the wolfram-carbide cutting-wheel to the guide resulting in maximum efficacy, precision and quality of cut.
- To cut tiles thicker than 6 mm (1/4") use the pliers 169TM01AN (accessory). Made of sturdy galvanized steel they are provided with knob to apply progressive and precise pressure exactly on the scoring line.
- The accessory extension (art. 433CRP100) offering a cutting length of 103 cm (3.4 ft.) if used alone, allows the RAIZOR system to reach a maximum length of cut of 447 cm (14.7 ft.) or 275 cm (9 ft.) by using only one profile/guide plus the extension.
- Add the cutting unit with angle grinder POWER-RAIZOR (accessory) to perform cuts (45°/90°/180°) with diamond disc.

SPECIFICATIONS AND VERSIONS

Part No.	Barcode	Quantity	Description	length of cut	bag size	Weight	Dimensions	Weight
433CR R	8050532001312	1	RAIZOR - complete cutting system for cutting up to 332 cm (10.9 ft): • two connectable guides with cutting length of 160 cm (5.2 ft.) each; • die-cast cutting unit provided w/ wolfram carbide wheel Ø 16 mm (5/8") and pin (pin rotates on bearings); • cutting-off pliers for tiles/slabs with thickness from 3 to 6 mm (1/8" - 1/4"); • padded bag with shoulder-straps and provided with inside modular compartments and pocket.	332 cm - 10.9'	180x25x h 16 cm - 71"x10"x h 6 3/8"	9 Kg - 19.8 lbs	186x27x h 18 cm - 73"x10 1/2"x h 7"	9,5 Kg - 21 lbs



TOOLS FOR LARGE FORMAT TILES



EXTENSION FOR RAIZOR AND CUTTING-OFF PLIER FOR THICK TILES

- Extruded aluminum extension for RAIZOR equipped with 2 stain-free-rubber suction cups \varnothing 88 mm (3 1/2") and connecting system. By combining the extension to both RAIZOR's guides or just one of them, the system offers the maximum flexibility in terms of length of cut (maximum 447 cm - 14.7 ft.). The extension can also be used alone (length of cut: 103 cm - 3.4 ft.). It fits in its specific compartment in RAIZOR's bag.
- Cutting-off pliers for tiles/slabs thicker than 6 mm - 1/4" (art.169TM01AN). Made of sturdy galvanized steel they are provided with knob to apply progressive and precise pressure exactly on the scoring line. Dual position rotating presser and breaker allows to use the plier at begin/end of cut or along the strip (longitudinal/parallel to the incision/scoring). Width-adjustable rubber feet to fit for different widths of cut maximizes the leverage effect when applying pressure.

Part No.	Barcode	Quantity	Description	length of cut	Weight	Dimensions	Weight
433CRP100	8050532003019	1	115 cm (3.8 ft.) extension for RAIZOR with 2 stain-free suction cups	103 cm - 40 1/2"	2,5 Kg 5.5 lbs	127x18x h 12 cm	3,3 Kg 7.3 lbs
169TM01AN	8024648067470	1	Cutting-off plier for tile with thickness 6-20 mm (1/4" - 3/4")	-	1,3 Kg 2.8 lbs	38x18xh 8 cm	1,5 Kg 3.3 lbs

ACHIEVABLE CUTTING LENGTHS ACCORDING TO THE VARIOUS POSSIBLE COMBINATIONS OF RAIZOR + EXTENSION

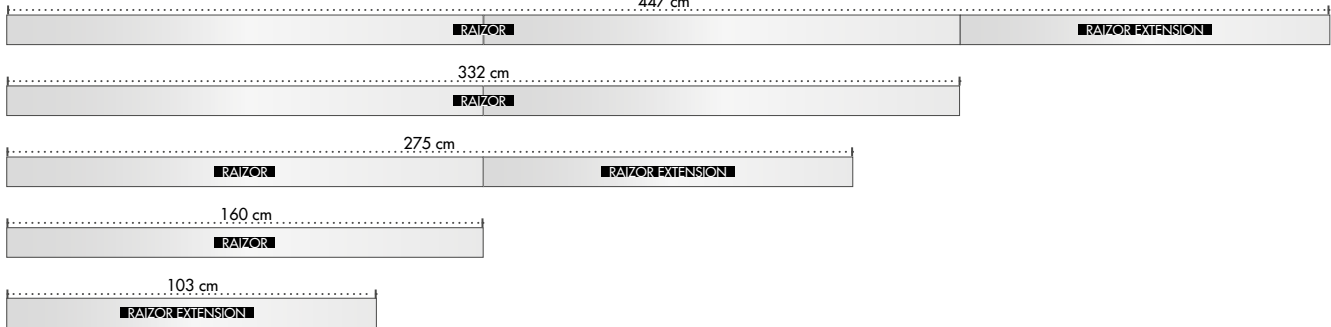

SPARE PARTS FOR RAIZOR

Part No.	Barcode	Quantity	Description	Weight
169TR01A	8024648078063	1	Cutting-off pliers for tile/slab with max thickness of 6 mm (1/4")	330 gr 11.6 oz
135D16A	8024648073419	1	Wheel \varnothing 16 mm (5/8") with pin	10 gr 0.35 oz



POWER RAZOR - MULTI-ANGLE CUTTING UNIT WITH ANGLE GRINDER

MADE IN ITALY

NEW



433PWR EU



433PWR0H



179CCT125



179FLEX006SE
179FLEX010SE



PACKAGE
CARTON BOX

- Multi-angle cutting unit with angle grinder to be used in combination to the RAZOR cutting guide.
 - It performs cuts with the following angles: 45° ("jolly", miter cut), 90° (standard/vertical cut), 180° (lateral incision - kerf/ slots along the side of the tile/slab, and/or side shaping - 1/2 bullnose).
 - In addition to those positions, it also cuts at the following intermediate angles: 30°/47°/70°.
 - Tilting movement (plunge cut) to adjust the depth of cut, to perform square and rectangular holes and to make cuts in multiple passes.
 - Available with or without the angle grinder.
 - Suitable with the most popular brands and models of angle grinders.
 - Available in 2 different versions to suit the following angle grinder arbor sizes: M14 (metric) or 5/8"-11 (imperial).
 - Dry use (standard version) or wet use (to perform wet cut in combination with Kit for wet cut and dust suppression - Art. 433PWW A, Power Razor must be equipped with cordless/battery operated angle grinder or corded model having rating IP54* or any higher).
 - Includes connecting port for connection either to dust extractor or to Kit for wet cut and dust suppression (Art.433PWW A).
 - Cutting depth (thickness): 20 mm (0.78") at 90°, 16 mm (0.63") at 45° and 180°.
- *Safety Regulations may vary from Country to Country. Therefore, it is strongly recommended to refer & comply to the legislation in force on the Country where the products is being used.

ACHIEVABLE CUTTING LENGTHS ACCORDING TO THE VARIOUS POSSIBLE COMBINATIONS OF POWER-RAZOR AND RAZOR + ITS EXTENSION

▼ 437 cm (14.34 ft.) | ■ 429 cm (14.07 ft.)

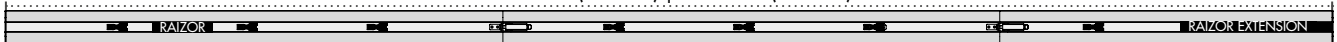

▼ 322 cm (10.56 ft.) | ■ 314 cm (10.3 ft.)

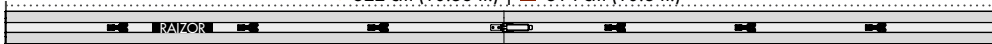

▼ 265 cm (8.69 ft.) | ■ 257 cm (8.43 ft.)



▼ 150 cm (4.92 ft.) | ■ 142 cm (4.66 ft.)



▼ 93 cm (3.05 ft.) | ■ 85 cm (2.79 ft.)

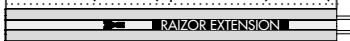

▼ plunge cut
■ no plunge cut

SPECIFICATIONS AND VERSIONS

Part No.	Box	Barcode	Description	Arbor	Disc	Angle	Speed	Power	Depth	Width	Height	Weight	Dimensions
433PWR EU	1	8050532003088	POWER RAZOR with angle grinder	M14	Ø125 mm (5") turbo	•	230V 50/60Hz	900 W	20 mm 0.79"	16 mm 0.63"	16 mm 0.63"	6,9 Kg 15.2 lbs	39x39x h14 cm
433PWR0HR	1	8050532003170	POWER RAZOR without angle grinder	M14	-	•	-	-	20 mm 0.79"	16 mm 0.63"	16 mm 0.63"	4,3 Kg 9.5 lbs	15 3/8"x15 3/8"x h 5 1/2"
433PWR0HRUS	1	8050532004467	POWER RAZOR without angle grinder	5/8"-11	-	•	-	-	20 mm 0.79"	16 mm 0.63"	16 mm 0.63"	4,3 Kg 9.5 lbs	-

DIAMOND BLADES AND WHEELS

Part No.	Box	Barcode	Description	Disc	Wheel
179CCT125	1	8024648075703	Turbo diamond disc Ø 125 mm – 5" (f 22,2 mm)	Ø 125 mm 5"	-
179FLEX006SE	1	8024648094834	Shaping wheel for 1/2 bullnose, radius 6 mm (1/4"), Ø 120mm (4 3/4")	-	6 mm 1/4"
179FLEX010SE	1	8024648087171	Shaping wheel for 1/2 bullnose, radius 10 mm (3/8"), Ø 120mm (4 3/4")	-	10 mm 3/8"



TOOLS FOR LARGE FORMAT TILES



PACKAGE



KIT FOR WET CUT AND DUST SUPPRESSION

- Wet cooling device to be used in combination with POWER RAIZOR.
- Blade cooling with water grants:
 - 1) Complete suppression of dust.
 - 2) Better cut finishing.
 - 3) Quicker cut.
- Both adjustments onto tap and onto spraying nozzle allow a perfect cooling with a minimal amount of water.

- To be used only in combination with cordless (battery operated) angle grinders and/or corded models having rating IP 54* or any higher.
- It can be used with any cutting position/angle (45°/90°/180°).
- Carrytank capacity of 8 litres (1,75 gal) with relief valve.

*Safety Regulations may vary from Country to Country. Therefore, it is strongly recommended to refer & comply to the legislation in force on the Country where the products is being used.

SPECIFICATIONS AND VERSIONS

Part No.			Description	USE			
433PWW A	1	8050532004573	Kit for wet cut and dust suppression for POWER RAIZOR	and/or	8 lt 1,75 gal	2,4 Kg 5.3 lbs	58x30x h25 cm 23"x12"x h 10"

DUST CONTAINMENT DEVICE

- Dust containment device to be used in combination with POWER RAIZOR cutting unit..
- Used in combination with a proper aspirator, it allows to radically reduce the amount of dust on the environment while dry cut is performed.
- The device can be used onto POWER RAIZOR equipped with any kind of angle grinder.

- Adjustable according with slab thickness.
- Can be used for 45° miter cut and 90° straight cut.

SPECIFICATIONS AND VERSIONS

Part No.			Description	USE		
433PWZP A	1	8050532004412	Dust containment device for POWER RAIZOR	any angle grinder model	0,5 Kg 1.1 lbs	27x15x h10 cm 10 5/8"x6"x h 4"

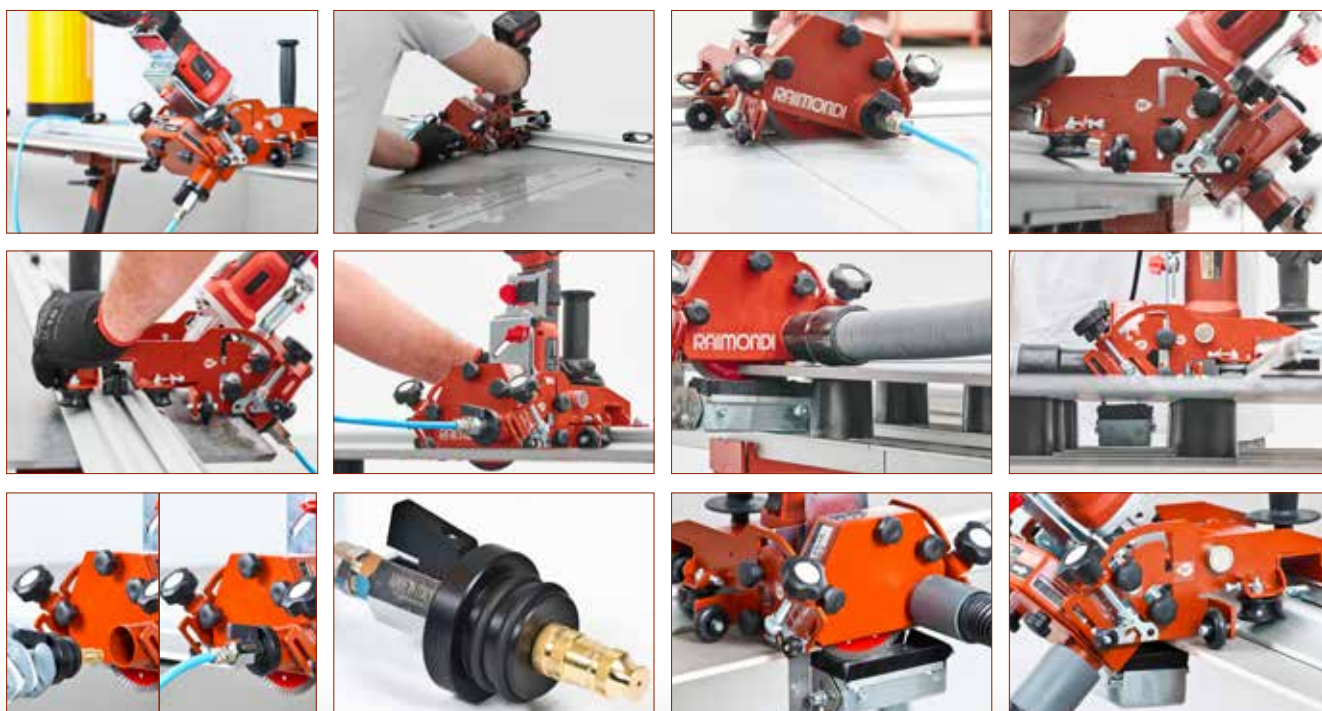

FREE-CUT - CUTTING SYSTEM FOR LARGE FORMAT TILES

MADE IN ITALY



ANTIOSSO
ANTIMACCHIA
STAIN FREE
SUCTION CUPS

ANTIOSSO
ANTIMACCHIA
STAIN FREE
SUCTION CUPS



169GP



169TR01A



169TM01AN

OPTIONAL



PROFILING DEVICE



90° CUTTING UNIT



35°/55° CUTTING UNIT



THICK TILES PLIERS



VACUUM SUCTION CUP

PACKAGE



CARTON BOX

FREE-CUT: CUTTING SYSTEM FOR LARGE FORMAT TILES UP TO 426 cm (14') LENGTH

- Free-Cut is a system made up of main guides and extensions. Both available in several lengths. Combine them to reach the required cutting length.
- Both main guides and extension are made with sturdy aluminum extruded profiles and are equipped with stain-free-rubber suction cups Ø 120 mm (4 3/4") for best fixing to the slab.
- Main guides come with a case containing: die-cast cutting unit with steel wheel-holder pin, cutting-off pliers for tiles/slabs with maximum thickness of 6 mm (1/4"), side squares (which also has the function to protect the wolfram carbide wheel).
- Cutting unit is made of die-cast aluminum and runs onto the guide thanks to 3 polypropylene pulleys, each equipped with two internal bearings. Furthermore, the cutting unit is provided with fine adjustment devices (factory-calibrated) for perfect alignment of the wolfram carbide wheel with the guide and to avoid any sort of play. This confers maximum efficacy, precision and quality of cut.
- To cut tiles thicker than 6/7 mm - 1/4" (max 20 mm - 3/4") use the pliers 169TM01AN (accessory). Made of sturdy galvanized steel they are provided with knob to apply progressive and

precise pressure exactly on the scoring line.

- Free-Cut accept the following accessories: "vacuum" (pump) suction cups kits for use on textured material (ref. 169GP); cutting unit with angle grinders Free-Flex 90° and Free-Flex 35°/55°; edge profiler for half bullnose.
- Main guide: 169FC150N (length of cut 156 cm - 5.1'); 169FC200N (length of cut 206 cm - 6.8').
- Extensions: 169FC150PN (length 170 cm - 5.6'); 169FC200PN (length 220 cm - 7.2'); 169FC100PN (length 100 cm - 3.3').

SPECIFICATIONS AND VERSIONS FREE-CUT

Part No.	Barcode	Description	Length				Weight	Dimensions	Weight
			Without extension	With extension 100 cm	With extension 170 cm	With extension 220 cm			
169FC150N	8024648081094	Free-Cut guide with complete outfit (max cut length 156 cm-5.2')	156 cm 5.2'	256 cm 10.7'	326 cm 10.7'	376 cm 12.3'	11 Kg 24.3 lbs	180x Ø17 cm + 39x39xh 14 cm 71"x Ø7" + 15 3/8"x15 3/8"xh 5 1/2"	13 Kg 28.6 lbs
169FC200N	8024648085528	Free-Cut guide with complete outfit (max cut length 206 cm-6.8')	206 cm 6.8'	306 cm 10'	379 cm 12.3'	426 cm 14'	15 Kg 33 lbs	227x Ø17 cm + 39x39xh 14 cm 89"x Ø7" + 15 3/8"x15 3/8"xh 5 1/2"	18 Kg 39.6 lbs

SPECIFICATIONS AND VERSIONS EXTENSIONS FREE-CUT

Part No.	Barcode	Description	Length		Weight		Dimensions		Weight	
			cm	ft	Kg	lbs	cm	in	Kg	lbs
169FC100PN	8024648096739	"Free-Cut" extension; Length 100 cm (3.3')	100 cm	3.3'	5 Kg	11 lbs	115x Ø17 cm	46"x Ø7"	10 Kg	22 lbs
169FC150PN	8024648084934	"Free-Cut" extension; Length 170 cm (5.6')	170 cm	5.6'	8 Kg	17.6 lbs	180x Ø17 cm	71"x Ø7"	10 Kg	22 lbs
169FC200PN	8024648084958	"Free-Cut" extension; Length 220 cm (7.2')	220 cm	7.2'	12 Kg	26.4 lbs	227x Ø17 cm	89"x Ø7"	15 Kg	33 lbs

OTHER ACCESSORIES AND SPARE PARTS FOR FREE-CUT

Part No.	Barcode	Description	Dimensions		Weight	
			cm	in	Kg	lbs
169TM01AN	8024648098870	Cutting-off pliers for tile/slab with thickness 6 (1/4") up to 20 mm (3/4")	33x17xh 8 cm	13"x7"h 3"	2 Kg	4.4 lbs
169TR01A	8024648078063	Cutting-off pliers for tile/slab with max thickness of 6 mm (1/4")	-	-	-	-
135D16A	8024608083630	Wheel Ø 16 mm (5/8") with pin	-	-	-	-
169GP	8024648086037	Pair of vacuum suction cups kits for "FREE-CUT"	33x33xh 10 cm	13"x13"xh 4"	4,1 Kg	9 lbs



TOOLS FOR LARGE FORMAT TILES

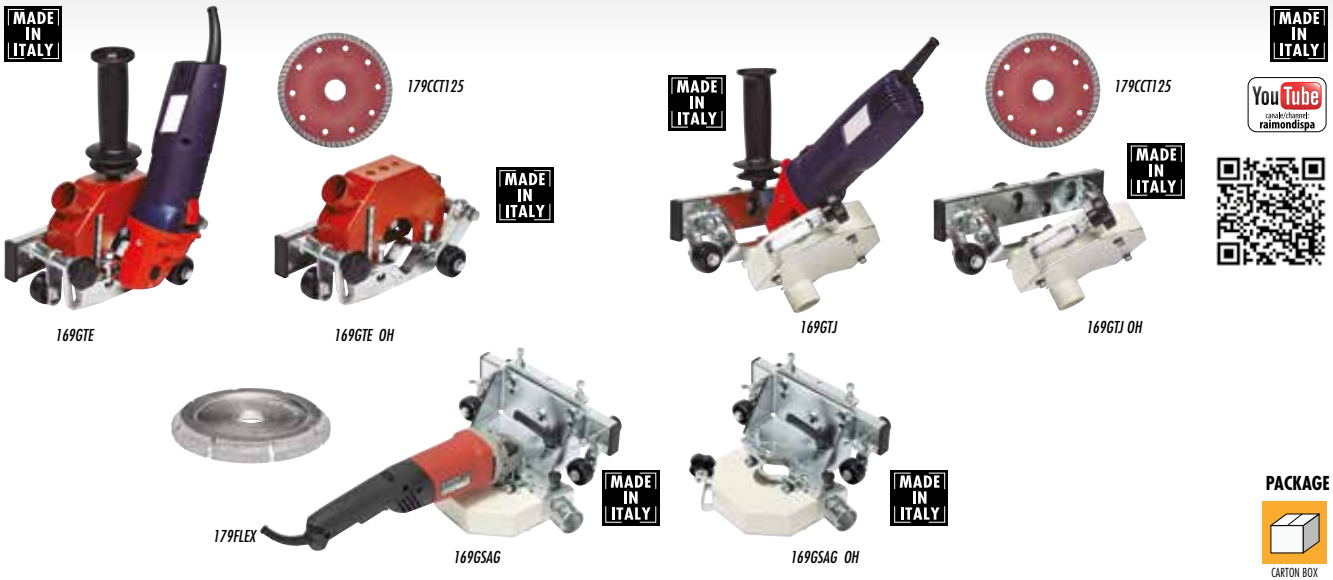

FREE-FLEX 90° - 90° CUTTING UNIT WITH ANGLE GRINDER FOR FREE-CUT

- To be mounted on cutting guides FREE-CUT for performing 90° cuts.
- Tilting movement (plunge cut) to adjust the depth of cut and to make cuts in multiple passes as well as to perform cut in the middle of the slab, square and rectangular holes.
- Depth of cut: 15 mm (5/8") with disc Ø 125 mm (5").
- Equipped with semi-universal attachment: compatible with the most popular brands and models of angle grinders.

- Ø 150 mm (6") disc can also be mounted: depth of cut: 25 mm (1").
- Provided with clutch hose for dust extraction.
- Dry cut with diamond blade.
- Available both with or without angle grinder (version with angle grinder includes Ø 125 mm - 5" turbo dry use diamond disc).

FREE-FLEX 35°/55° - 35°/55° VARIABLE ANGLE CUTTING UNIT WITH ANGLE GRINDER FOR FREE-CUT

- To be mounted on cutting guides FREE-CUT.
- Provided with tilting system to miter angle from 35° to 55° on large format tiles.
- Depth of cut: 15 mm (5/8") with disc Ø 125 mm (5").
- Ø 150 mm (6") disc can also be mounted: depth of cut: 20 mm (3/4").
- Equipped with semi-universal attachment: compatible with the most popular brands and models

- of angle grinders.
- Provided with clutch hose for dust extraction.
- Dry cut with diamond blade.
- Available both with or without angle grinder (version with angle grinder includes Ø 125 mm - 5" turbo diamond disc dry use).

PROFILING DEVICE – DEVICE WITH ANGLE GRINDER FOR CREATING 1/2 BULLNOSE

- To be mounted on cutting guides FREE-CUT for performing half bullnose profile on large format tiles up to 10 mm (13/32") radius.
- Two dry use diamond wheels available: radius 6 mm-1/4" (min) and 10 mm-13/32" (max). Both Ø 120 mm (4 3/4").
- The profiling device can works up to 25 mm (1") thickness tiles. In this case it will bullnose just the upper part of edge of the tile.
- Equipped with semi-universal attachment: compatible with the most popular brands and models

- of angle grinders.
- Suggested speed of the wheels: 4000 rpm; approximate angle grinder power: 1400W.
- Diamond wheel not included.
- Dry use diamond wheels only.
- Available both with or without angle grinder.
- Provided with clutch hose for dust extraction.

SPECIFICATIONS AND VERSIONS

Part No.	Barcode	Box	Description	Power	Image	Dimensions	Weight
169GTE 230V	8024648082527	1	"FREE-FLEX 90°" Plunge-cut unit 90° with angle grinder 900W 230V 50/60 Hz and continuous rim diamond disc Ø 125 mm (5"). Semi-universal attachment.	230V 50/60 Hz			
169GTE 110V	8024648091987	1	"FREE-FLEX 90°" Plunge-cut unit 90° with angle grinder 900W 110V 60 Hz and continuous rim diamond disc Ø 125 mm (5"). Semi-universal attachment.	110V 60 Hz		40x28x h25 cm 16"x11"x h10"	5,5 Kg 12 lbs
169GTE 110GB	8024648095831	1	"FREE-FLEX 90°" Plunge-cut unit 90° with angle grinder 900W 110V 50 Hz and continuous rim diamond disc Ø 125 mm (5"). Semi-universal attachment.	110V 50 Hz		40x28x h25 cm 16"x11"x h10"	3,2 Kg 7 lbs
169GTE OH	8024648086457	1	Plunge-cutting unit 90° without angle grinder. Without disc. Semi-universal attachment: compatible with the most popular brands and models of angle grinders.	-		40x28x h25 cm 16"x11"x h10"	3,2 Kg 7 lbs
169GTJ 230V	8024648086471	1	"FREE-FLEX 35°/55°" Variable angle 35°/55° cutting unit with angle grinder 900W 230V 50/60 Hz and turbo diamond disc Ø 125 mm (5"). Semi-universal attachment.	230V 50/60 Hz			
169GTJ 110V	8024648091994	1	"FREE-FLEX 35°/55°" Variable angle 35°/55° cutting unit with angle grinder 900W 110V 60 Hz and turbo diamond disc Ø 125 mm (5"). Semi-universal attachment.	110V 60 Hz		40x28x h25 cm 16"x11"x h10"	5,8 Kg 12,8 lbs
169GTJ 110GB	8024648095848	1	"FREE-FLEX 35°/55°" Variable angle 35°/55° cutting unit with angle grinder 900W 110V 50 Hz and turbo diamond disc Ø 125 mm (5"). Semi-universal attachment.	110V 50 Hz		40x28x h25 cm 16"x11"x h10"	3,5 Kg 7,7 lbs
169GTJ OH	8024648083173	1	35°/55° variable angle cutting unit without angle grinder. Without disc. Semi-universal attachment: compatible with the most popular brands and models of angle grinders.	-		40x28x h25 cm 16"x11"x h10"	3,5 Kg 7,7 lbs
179CCT125	8024648075703	1	Continuous rim diamond disc Ø 125 mm (5") for "Free-Flex" (inner hole 22,2 mm) – dry use	-		-	-
169GSAG 230V	8024648094780	1	Profiling device with angle grinder 1400W 230V 50/60 H. Without wheel. Semi-universal attachment.	230V 50/60 Hz		40x28x h25 cm 16"x11"x h10"	7,1 Kg 15,6 lbs
169GSAG OH	8024648061515	1	Profiling device without angle grinder. Without wheel. Semi-universal attachment: compatible with the most popular brands and models of angle grinders.	-		40x28x h25 cm 16"x11"x h10"	4,2 Kg 9,3 lbs
179FLEX006SE	8024648094834	1	Shaping wheel for 1/2 bullnose, radius 6 mm (1/4"), Ø 120mm (4 3/4") – dry use	-		-	-
179FLEX010SE	8024648087171	1	Shaping wheel for 1/2 bullnose, radius 10 mm (13/32"), Ø 120mm (4 3/4") – dry use	-		-	-



BM180^{PLUS} - ADJUSTABLE WIDTH (100-150 cm / 3.3'- 5') TABLE FOR LARGE FORMAT TILES

MADE IN ITALY



min: 100 cm (3.3')
max: 150 cm (5')

394MA PLUS

PACKAGE



"BM180^{PLUS}" with folding legs/transport position



2 "BM180^{PLUS}" combined



Worktop dim: 360x100 cm

2 "BM180^{PLUS}" combined



Worktop dim: 360x150 cm

- BM 180^{PLUS} is a variable width table designed to be the perfect workstation for large format tiles up to 160 cm (5.3') and to be easy to transport.
- With few simple movements, the width of the worktop can vary from a minimum of 100 cm (3.3') to a maximum of 150 cm (5') with intermediate steps.
- In order to obtain an optimal worktop for any chosen width, the aluminum profiles are easily movable.
- When changing the width of the table the legs move as well, therefore they always maintain the optimal position to guarantee the maximum stability and strength of the bench at any chosen width.
- The length of the top is 180 cm (5.9'). Connect two tables together to obtain a worktop of 360 cm (11.8') in length (and variable with from 100 to 150 cm – 3.3' to 5'). This feature makes the BM180^{PLUS} the perfect workstation for slabs of any size.
- When in minimum width position, the bench is compact and easy to transport and store. Its folding legs make it even more practical.
- Being the anodized aluminum profiles (which make up the worktop) spaced and movable, it is

possible to perform cuts with angle grinder and diamond blade without damaging them. Moreover, the special tile-support-cylinders (available as an accessory) create a gap between the tile and the worktop allowing to perform cuts with angle grinders in every direction without damaging the bench.

- Legs provided with adjustable feet for perfect leveling of the bench.
- The steel structure and the worktop made of anodized aluminum profiles assure maximum strength and stability.
- It possible to eventually add extra aluminum profiles (accessory).
- Main important specifications:
- Width: variable/adjustable from 100 to 150 cm (from 3.3' up to 5');
- Length: 1 bench 180 cm (5.9'); 2 benches combined 360 cm (11.8');
- Height of the worktop from the ground: 83 cm (32 3/4");
- Maximum load capacity: 150 Kg (331 lbs).
- Wide range of accessories available.

SPECIFICATIONS AND VERSIONS

Part No.	Barcode	Qty	Description	Weight	Dimensions	Volume	Volume	
394MA PLUS	8050532007062	1	BM180 ^{PLUS} adjustable width (100-150 cm / 3.3'- 5') table for large format tiles	38 Kg 83.7 lbs	190x21 x h 10 cm 117x20x h 20 cm	75" x 8 1/4" x 3 1/2"	46" x 8" x 8"	39,6 Kg 87.3 lbs

ACHIEVABLE WORKTOP DIMENSIONS WITH TWO BM180^{PLUS} BENCHES ONLY

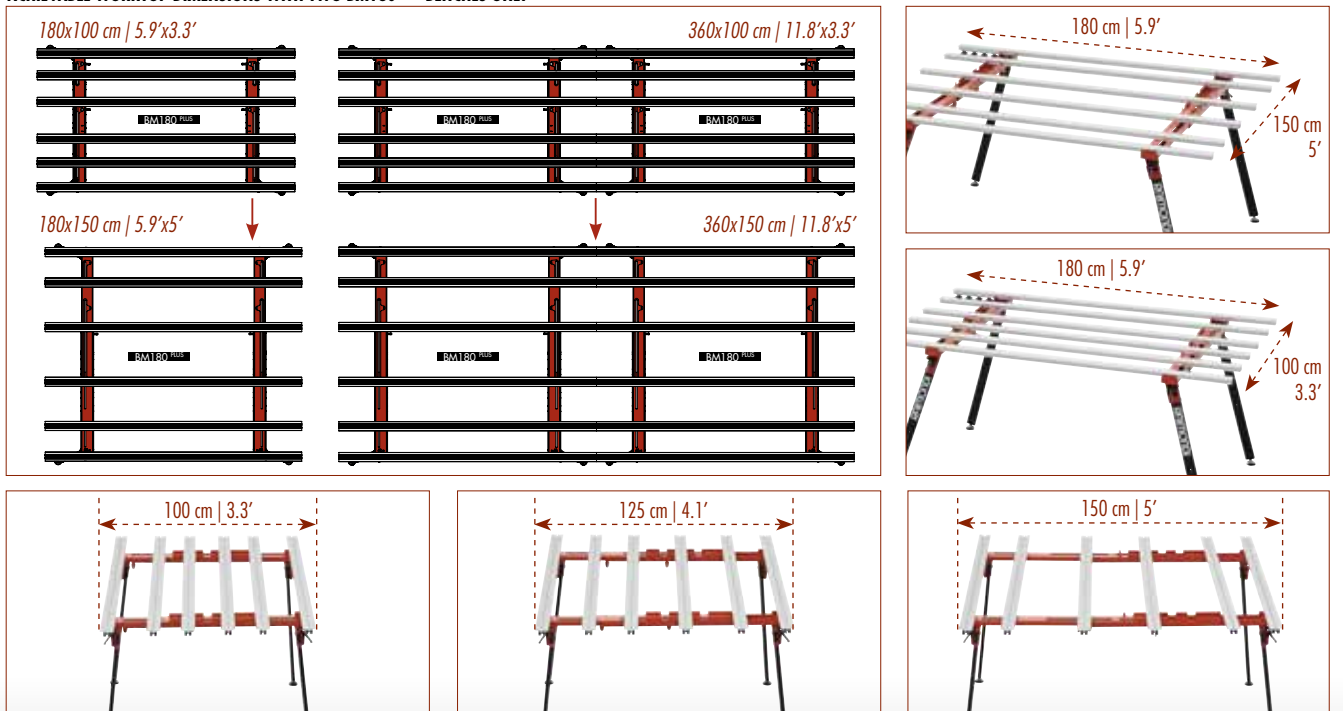

TOOLS FOR LARGE FORMAT TILES



394MA RAI

PACKAGE



"BM180 ^{MkII}" with folding legs/transport position



2 "BM180 ^{MkII}" combined



- BM180 ^{MkII} is the ideal table for cutting and processing large format slabs.
- Worktop dimensions: single table 180 x 90 cm (3'x6'); two combined tables 360x90 cm (11.8'x2.9').
- Thanks to the range of dedicated extensions (accessories) and the possibility to combine two BM180^{MkII} together, the worktop can extend up to 420 cm (13.8') or even more if needed, passing through intermediate measures such as 360 cm (11.8'), 270 cm (8.9') and 240 cm (7.9'). Width can reach up to 150 cm. All these combinations make the BM180^{MkII} perfect for tiles of any dimension.
- Being the anodized aluminum profiles (which make up the worktop) spaced and movable, it is possible to perform cuts with angle grinder and diamond blade without damaging them. Moreover,

- the special tile-support-cylinders (available as an accessory) create a gap between the tile and the worktop allowing to perform cuts with angle grinders in every direction without damaging the bench.
- Legs provided with adjustable feet for perfect leveling of the bench.
- The steel structure and the worktop made of anodized aluminum profiles assure maximum strength and stability.
- Height: 83 cm (32 3/4"). Maximum load capacity (single table): 150 Kg (331 lbs.).
- Wide range of dedicated accessories available.

SPECIFICATIONS AND VERSIONS

Part No.			Description			
394MA RAI	8050532000995	1	BM180 ^{MkII} modular bench with folding legs	29 Kg / 63.9 lbs	190x21x h 10 cm + 117x20x h 20 cm 75"x 8 1/4" x 3 1/2" + 46"x8" x h 8"	30,9 Kg / 68.1 lbs



180x90 cm | 5.9'x3'

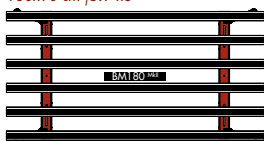

360x90 cm | 11.8'x3'

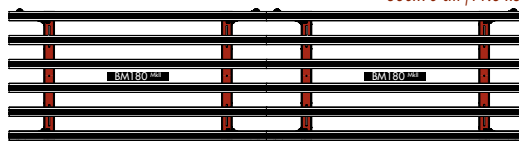

EXTENSIONS FOR MODULAR TABLE BM180 MKII

MADE IN ITALY

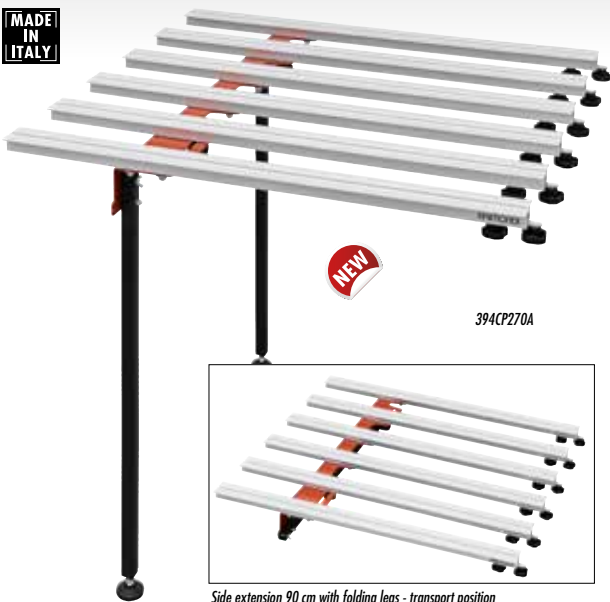

Side extension 90 cm with folding legs - transport position



394CP240A

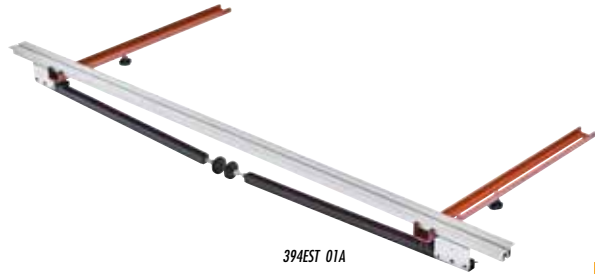

394EST 01A

PACKAGE



CARTON BOX

SPECIFICATIONS AND VERSIONS

Part No.	Barcode	Quantity	Description	Weight	Dimensions	Weight	Dimensions	Weight	Dimensions
394CP270A	8050532005136	1	Side extension complete w/6 aluminum profiles and folding legs to lengthen the bench of 90 cm (35 1/2")	11,6 Kg	25.6 lbs	117x20x h20 cm	46"x8"x h 8"	12,5 Kg	27.5 lbs
394CP240A	8050532000599	1	Pair of side telescopic extensions to lengthen the bench up to 30 cm (12") each side (60 cm - 24" tot)	6,2 Kg	13.7 lbs	140x14xh 8 cm	55 1/8"x 5 1/2" xh 3"	7,2 Kg	15.9 lbs
394EST 01A	8050532000124	1	Side telescopic extension to widen the bench up to 60 cm - 23 5/8" (worktop total width 150 cm - 4.9')	8,2 Kg	18.1 lbs	190x Ø17 cm	46"x Ø 8"	10,2 Kg	22.5 lbs

EXAMPLE OF ACHIEVABLE WORKTOP DIMENSIONS WITH TWO BM180 MKII AND EXTENSIONS

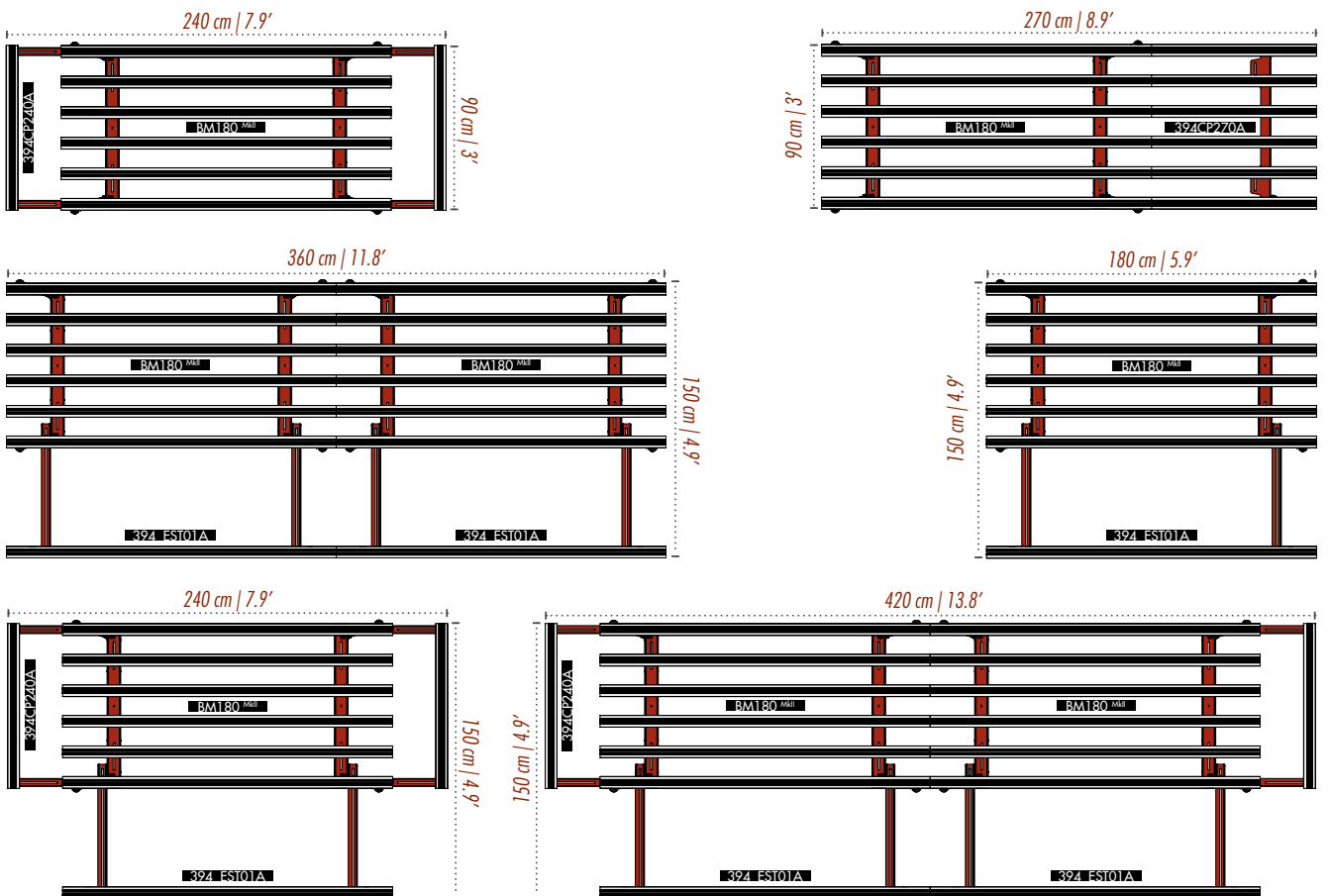

1 pz art. 394CP240A
Working table dim.: 240x90 cm



2 pz art. 394EST 01A
Working table dim.: 360x150 cm



1 pz art. 394CP270A
Working table dim.: 270x90 cm

TOOLS FOR LARGE FORMAT TILES



PACKAGE

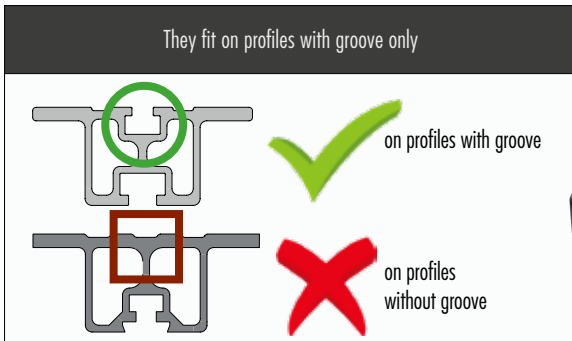

KIT OF 20 TILE-SUPPORT CYLINDERS TO PERFORM CUT WITH ANGLE GRINDER ON BM180^{MkII} AND BM180^{PLUS} TABLES

- To perform with ease cuts with angle grinder (even I-shaped and/or squares holes) on tiles up to 160x320 cm (5.3'x11.9') in any direction.
- One kit consists of 20 polypropylene supports (h56 mm - Ø 60 mm | h2.2" - Ø 2.4") that once inserted along the aluminum profiles, supports the tile and creates a gap between it and the worktop. This allows to perform cuts with angle grinders in any direction without damaging the bench.
- The possibility to freely positioning the cylinders at any point on the worktop allows to choose their layout according to the tile dimension and the kind of cut to be done. Even in the most difficult situations and for the most complex cuts.
- Inserting and fixing is extremely easy and fast: just insert the screw underneath each cylinder into the dedicated slot of each aluminum profiles (which made up the worktop) and slide the supports

in the desired position. Slightly rotate the cylinders to fix them.

- Its design and the premium quality polymer they are built with make the cylinders extremely sturdy. They are designed to support tiles of any weight and to last potentially forever.
- The supports are compatible with both BM180^{MkII} and BM180^{PLUS} as well as previous versions if equipped with top-grooved aluminum profiles.
- The supports do not preclude the use of the wide range of ACCESSORIES FORs dedicated to BM180 tables nor the use of POWER-RAIZOR both in combination with water-cut kit (Art.433PWWA) and/or the dust suppression device for dry cut (Art.433PWZPA).

SPECIFICATIONS AND VERSIONS KIT TILE-SUPPORT CYLINDERS

Part No.	Barcode	Box	Description	USE	Weight	Dimensions	Weight
394CC 01A	8050532004207	1	Kit of 20 tile-support cylinders for BM180 ^{MkII} and BM180 ^{PLUS}		0,9 Kg 1.9 lbs	39x39xh 15 cm 15 3/4"x15 3/4"x h 6"	1,2 Kg 2.8 lbs

SIDE PROFILES FOR SCORING AND CUT

- The side profile connects to the short side of the table offering a continuous support for score & cut the short side of the tile (i.e.: cut 120 cm side of a 120x240 cm tile).
- Available in two lengths: 124 cm and 164 cm (4' and 5.4'). Therefore, suitable even for the largest tiles.

- We recommend the use of the 164 cm (5.4') version only with BM180^{PLUS}.
- Version 124 cm (4') fits on both BM180^{MkII} and BM180^{PLUS}.
- Free to slide in and out when mounted so to not interfere with operator when doesn't need them.

SPECIFICATIONS AND VERSIONS FOR SIDE PROFILES FOR SCORING AND CUT

Part No.	Barcode	Box	Description	BM180 MkII	BM180 PLUS	Weight	Dimensions	Weight
394IS 1200	8050532007024	1	Side profiles for scoring and cut length 124 cm (4')	•	•	-	-	-
394IS 1600	8050532007031	1	Side profiles for scoring and cut length 164 cm (5.4')	-	•	-	-	-



TOOLS FOR LARGE FORMAT TILES

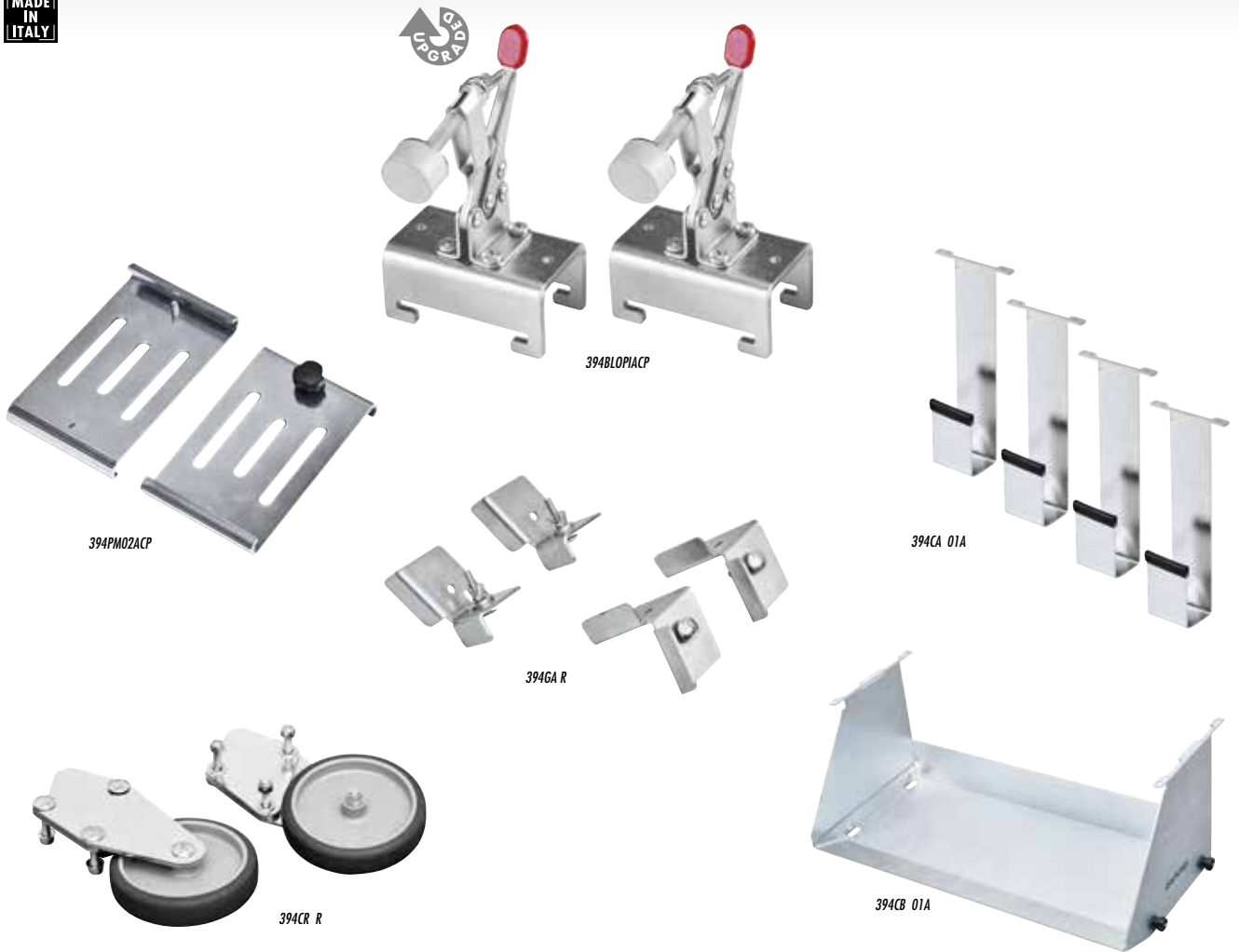

SPECIFICATIONS AND VERSIONS

Part No.			Description						
394BLOIACP	8024648096678	1	Stand-alone tile holder (for 3 to 30 mm thicknesses) - pair	0,9 Kg	2 lbs	27x15xh 10 cm	10 5/8" x 4" xh 6"	1 Kg	2.2 lbs
394PMO2ACP	8024648096722	1	Strips support - pair	0,6 Kg	1.3 lbs	27x15xh 10 cm	10 5/8" x 4" xh 6"	0,7 Kg	1.5 lbs
394CR R	8050532000940	1	Wheels for legs - pair	1,7 Kg	3.7 lbs	27x15xh 10 cm	10 5/8" x 4" xh 6"	1,8 Kg	4 lbs
394GA R	8050532000971	1	Kit of 4 supports for in-legs shelf (wooden shelf not provided)	1 Kg	2.2 lbs	27x15xh 10 cm	10 5/8" x 4" xh 6"	1,2 Kg	2.6 lbs
394CA 01A	8050532002364	1	Kit of 4 lateral steel hooks for hang up the cutting guides	0,5 Kg	1.1 lbs	37x17xh 8 cm	13" x 6 5/8" xh 3"	2 Kg	4.4 lbs
394CB 01A	8050532002388	1	Steel-made side tools box	4.9 Kg	10.8 lbs	58x28xh 23 cm	23" x 11" xh 9"	5,4 Kg	11.9 lbs



TOOLS FOR LARGE FORMAT TILES

MADE IN ITALY

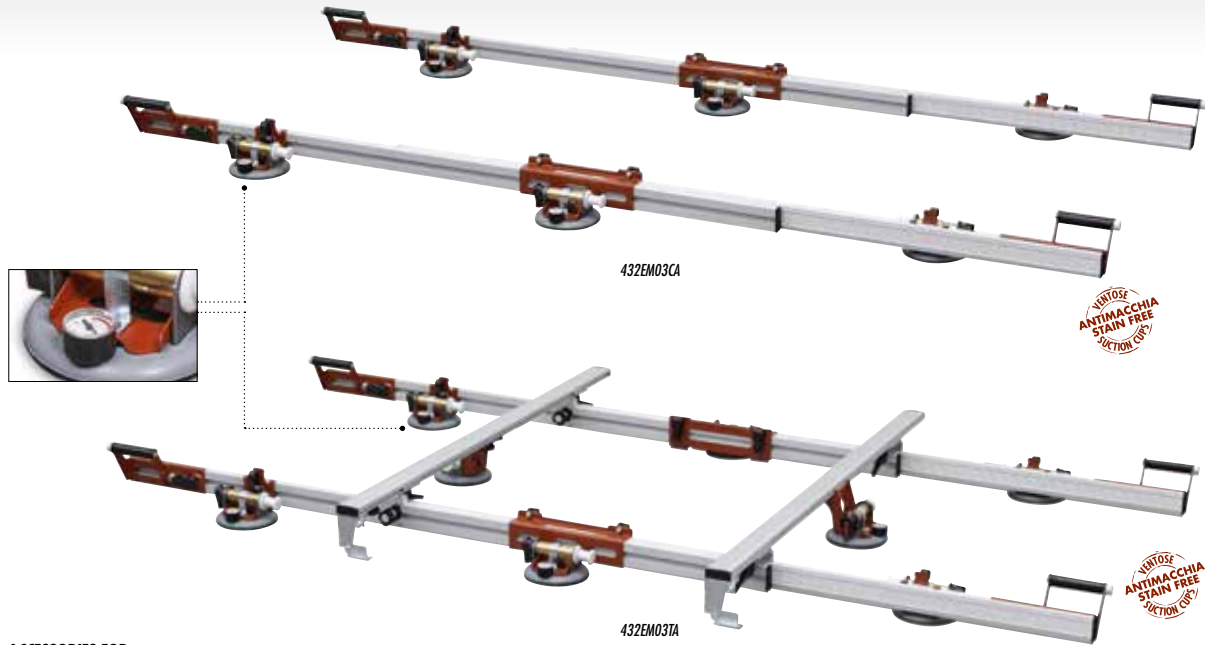

ACCESSORIES FOR EASY-MOVE^{MkIII} WITH CROSSBARS



DOUBLE GRIP HANDLE

ACCESSORIES FOR FOR EASY-MOVE^{MkIII}



DOUBLE GRIP HANDLE



CROSSBARS

PACKAGE



CARTON BOX

EASY-MOVE^{MkIII} WITH VACUUM SUCTION CUPS WITH VACUUM GAUGE: ADJUSTABLE EXTENSION DEVICE FOR HANDLING LARGE FORMAT TILES UP TO 320 cm (10.5') LENGTH

- Lightweight and easy to transport devices that give the maximum versatility thanks to the adjustable extension so to adapt to tiles sizes to handle them.
- Maximum tile/slab length: 320 cm (10.5'), minimum 100 cm (3.3'); in order to handle slabs with a shorter length, it is suggested to separate the two profiles and use just one of them.
- Made up of two pairs of aluminum profiles connected each other so that they can slide one over the other, it is available both with crossbars (8 suction cups in total) and without crossbars (6 suction cups in total).
- The suction cups units can slide along the aluminum profiles in few moments thanks to the "quick lock-release" handles system.
- Suction cups units are free to tilt/pivot (+/- 1.25°) so to adapt to the tile and therefore to provide the maximum grip in every situation. This is particularly useful for textured tiles.
- Equipped with "vacuum" (pump) suction cups Ø 150 mm (6") with vacuum gauge, perfect for textured tiles. Built with special stain-free rubber (grey color), which does not leave stains on the tiles.
- The "vacuum" (pump) system allows to restore or increase vacuum while suction cup is still attached to the tile.
- The vacuum gauge precisely indicates when it is needed to restore the vacuum.
- Sliding/telescopic handles (with "quick lock-release" handle system) to make the use of the product the most ergonomic as possible and to optimize the installation on wall. Equipped with anti-slip and stain-free rubber point.
- Crossbars are equipped with quick lock-release system and with safety hooks for extra security.
- Pair of crossbars and suction cup units for crossbars are available as accessories.
- Available as accessory a kit of 4 double grip handles to maximize ergonomics when the device is used by four operators.

SPECIFICATIONS AND VERSIONS

Part No.	Barcode	Box Icon	Description	Weight Icon	Weight	Dimensions Icon	Dimensions	Weight Icon	Weight
432EM03CA	8050532000650	1	EASY-MOVE ^{MkIII} with 6 "vacuum" (pump) suction cups with vacuum gauge (stain-free-rubber)	22,6 Kg	49.8 lbs	191x58xh 21 cm	75"x23"xh 8"	30 Kg	66 lbs
432EM03TA	8050532000711	1	EASY-MOVE ^{MkIII} with crossbars with 8 "vacuum" (pump) suction cups with vacuum gauge (stain-free-rubber)	32,5 Kg	71.7 lbs	191x58xh 21 cm+140x14xh 8 cm +40x40xh 15 cm	75"x23"xh 8"+55"x5 1/2"xh 3 1/8"+15 3/4"x15 3/4"xh 6"	41,4 Kg	91.2 lbs

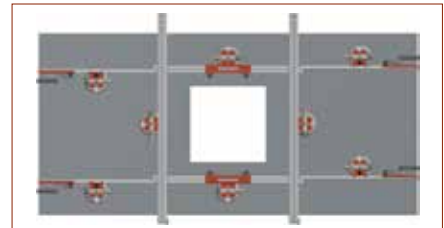
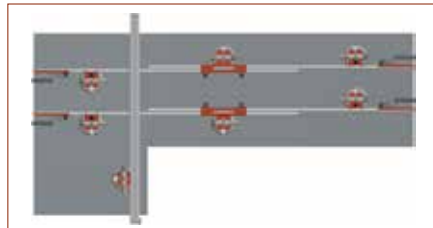

EASY-MOVE ^{MkIII} AND EASY-MOVE ^{MkIII} WITH CROSSBARS (VACUUM SUCTION CUPS)



MADE IN ITALY

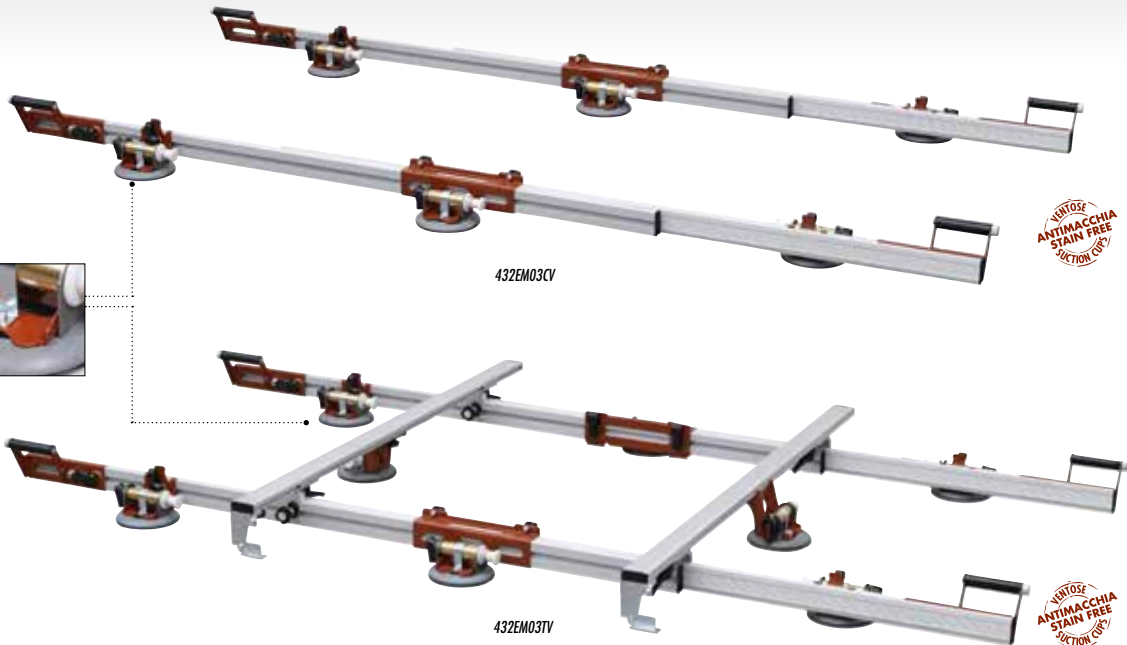

432EM03CV

432EM03TV

VERTOSE
ANTI MACCHIA
STAIN FREE
SUCTION CUP

VERTOSE
ANTI MACCHIA
STAIN FREE
SUCTION CUP

ACCESSORIES FOR EASY-MOVE ^{MkIII} WITH CROSSBARS



DOUBLE GRIP HANDLE

ACCESSORIES FOR EASY-MOVE ^{MkIII}



DOUBLE GRIP HANDLE



CROSSBARS

PACKAGE



CARTON BOX

EASY-MOVE ^{MkIII} WITH VACUUM SUCTION CUPS: ADJUSTABLE EXTENSION DEVICE FOR HANDLING LARGE FORMAT TILES UP TO 320 cm (10.5') LENGTH

- Lightweight and easy to transport devices that give the maximum versatility thanks to the adjustable extension so to adapt to tiles sizes to handle them.
- Maximum tile/slab length: 320 cm (10.5'), minimum 100 cm (3.3'); in order to handle slabs with a shorter length, it is suggested to separate the two profiles and use just one of them.
- Made up of two pairs of aluminum profiles connected each other so that they can slide one over the other, it is available both with crossbars (8 suction cups in total) and without crossbars (6 suction cups in total).
- The suction cups units can slide along the aluminum profiles in few moments thanks to the "quick lock-release" handles system.
- Suction cups units are free to tilt/pivot (+/- 1.25°) so to adapt to the tile and therefore to provide the maximum grip in every situation. This is particularly useful for textured tiles.
- Equipped with "vacuum" (pump) suction cups Ø 150 mm (6"), perfect for textured tiles. Built with special stain-free rubber (grey color), which does not leave stains on the tiles.
- The "vacuum" (pump) system allows to restore or increase vacuum while suction cup is still attached to the tile.
- Sliding/telescopic handles (with "quick lock-release" handle system) to make the use of the product the most ergonomic as possible and to optimize the installation on wall. Equipped with anti-slip and stain-free rubber point.
- Crossbars are equipped with quick lock-release system and with safety hooks for extra security.
- Pair of crossbars and suction cup units for crossbars are available as accessories.
- Available as accessory a kit of 4 double grip handles to maximize ergonomics when the device is used by four operators.

SPECIFICATIONS AND VERSIONS

Part No.	Barcode	Quantity	Description	Weight	Dimensions	Volume	Weight
432EM03CV	8050532000674	1	EASY-MOVE ^{MkIII} with 6 "vacuum" (pump) suction cups (stain-free-rubber)	22,6 Kg / 49.8 lbs	191x58xh 21 cm	75"x23"xh 8"	30 Kg / 66 lbs
432EM03TV	8050532000735	1	EASY-MOVE ^{MkIII} with crossbars with 8 "vacuum" (pump) suction cups (stain-free-rubber)	32,5 Kg / 71.7 lbs	191x58xh 21 cm+140x14xh 8 cm +40x40xh 15 cm	75"x23"xh 8"+55"x5 1/2"xh 3 1/8"+15 3/4"x15 3/4"xh 6"	41,4 Kg / 91.2 lbs

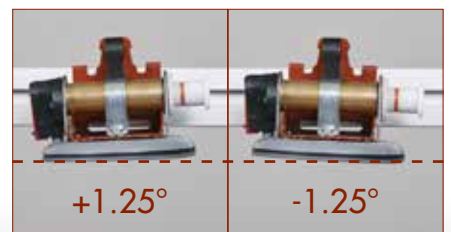

+1.25°

-1.25°

TOOLS FOR LARGE FORMAT TILES

EASY-MOVE M^{III} AND EASY-MOVE M^{III} WITH CROSSBARS (DOUBLE SUCTION CUPS)



MADE IN ITALY

VERTOSE
ANTIMACCHIA
STAIN FREE
SUCTION CUPS

VERTOSE
ANTIMACCHIA
STAIN FREE
SUCTION CUPS

432EM03CB

432EM03TB



ACCESSORIES FOR EASY-MOVE M^{III} WITH CROSSBARS



ACCESSORIES FOR FOR EASY-MOVE M^{III}



PACKAGE



EASY-MOVE M^{III} WITH DOUBLE SUCTION CUPS: ADJUSTABLE EXTENSION DEVICE FOR HANDLING LARGE FORMAT TILES UP TO 320 cm (10.5') LENGTH

- Lightweight and easy to transport devices that give the maximum versatility thanks to the adjustable extension so to adapt to tiles sizes to handle them.
- Maximum tile/slab length: 320 cm (10.5'), minimum 100 cm (3.3'); in order to handle slabs with a shorter length, it is suggested to separate the two profiles and use just one of them.
- Made up of two pairs of aluminum profiles connected each other so that they can slide one over the other, it is available both with crossbars (8 double suction cups / 16 rubber cups in total) and without crossbars (6 double suction cups / 12 rubber cups in total).
- The suction cups units can slide along the aluminum profiles in few moments thanks to the "quick lock-release" handles system.
- Suction cups units are free to tilt/pivot (+/- 1.25°) so to adapt to the tile and therefore to provide the maximum grip in every situation.
- Rubber cups Ø 120 mm (4 3/4") built with special stain-free rubber (grey color), which does not leave stains on the tiles.
- Sliding/telescopic handles (with "quick lock-release" handle system) to make the use of the product the most ergonomic as possible and to optimize the installation on wall. Equipped with anti-slip and stain-free rubber point.
- Crossbars are equipped with quick lock/release system and with safety hooks for extra security.
- Double suction cups can be replaced with vacuum suction cups (optional).
- Pair of crossbars and suction cup units for crossbars are available as accessories.
- Available as accessory a kit of 4 double grip handles to maximize ergonomics when the device is used by four operators.

SPECIFICATIONS AND VERSIONS

Part No.	Barcode	Box	Description	Weight	Dimensions	Volume	Net Weight	Gross Weight
432EM03CB	8050532000667	1	EASY-MOVE M ^{III} with 6 stain-free-rubber double suction cups (12 rubber cups in total)	21,5 Kg / 47.4 lbs	191x58xh 21 cm	75"x23"xh 8"	28,9 Kg	63.7 lbs
432EM03TB	8050532000728	1	EASY-MOVE M ^{III} with crossbars with 8 stain-free-rubber double suction cups (16 rubber cups in total)	30,8 Kg / 67.9 lbs	193x46xh 15 cm+140x14xh 8 cm +33x33xh 10 cm	76"x18"xh 6"+ 55"x5 1/2"xh 3 1/8"+13"x13"xh 4"	39,7 Kg	87.5 lbs

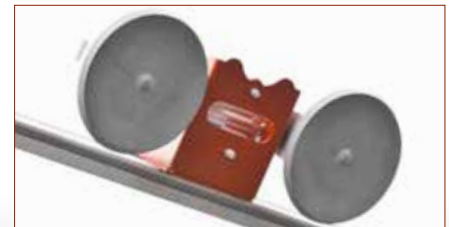
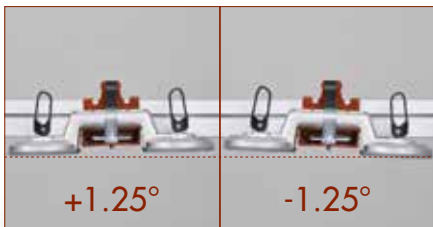
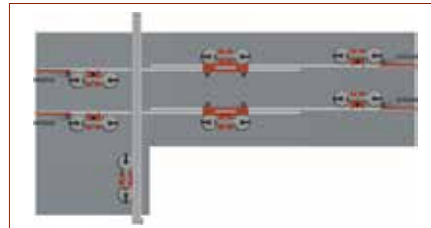
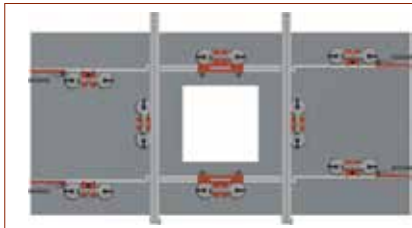

ACCESSORIES FOR EASY-MOVE MkIII



ACCESSORIES FOR EASY-MOVE MkIII

Part No.	Barcode	Quantity	Description	Weight (Kg)	Weight (lbs)	Dimensions (cm)	Dimensions (in)	Weight (Kg)	Weight (lbs)
432E003ID	8050532001022	1	Kit of 4 double grip handles for EASY-MOVE MkIII	4,1	9	40x40x15	15 3/4"x15 3/4"xh 6"	4,5	9.9
432E003TR	8050532001039	1	Pair of crossbars for EASY-MOVE MkIII	6,7	14.8	140x14x8	55"x5 1/2"xh 3 1/8"	7,7	17
432E003VB	8050532001053	1	Kit of 2 DOUBLE SUCTION CUPS for EASY-MOVE MkIII crossbars	2,6	5.7	33x33x10	13"x13"xh 4"	3	6.6
432E003VV	8050532001060	1	Kit of 2 VACUUM (pump) SUCTION CUPS for EASY-MOVE MkIII crossbars	3,2	7.1	40x40x15	15 3/4"x15 3/4"xh 6"	3,6	7.9
432E003VA	8050532001046	1	Kit of 2 VACUUM (pump) SUCTION CUPS WITH GAUGE for EASY-MOVE MkIII crossbars	3,2	7.1	40x40x15	15 3/4"x15 3/4"xh 6"	3,6	7.9
185V150CP	8050532001039	1	VACUUM (pump) SUCTION CUP with protection	1	2.2	33x33x10	13"x13"xh 4"	1,4	3.1
185V150PVT	8024648019578	1	VACUUM (pump) SUCTION CUP WITH GAUGE with protection	1	2.2	33x33x10	13"x13"xh 4"	1,4	3.1

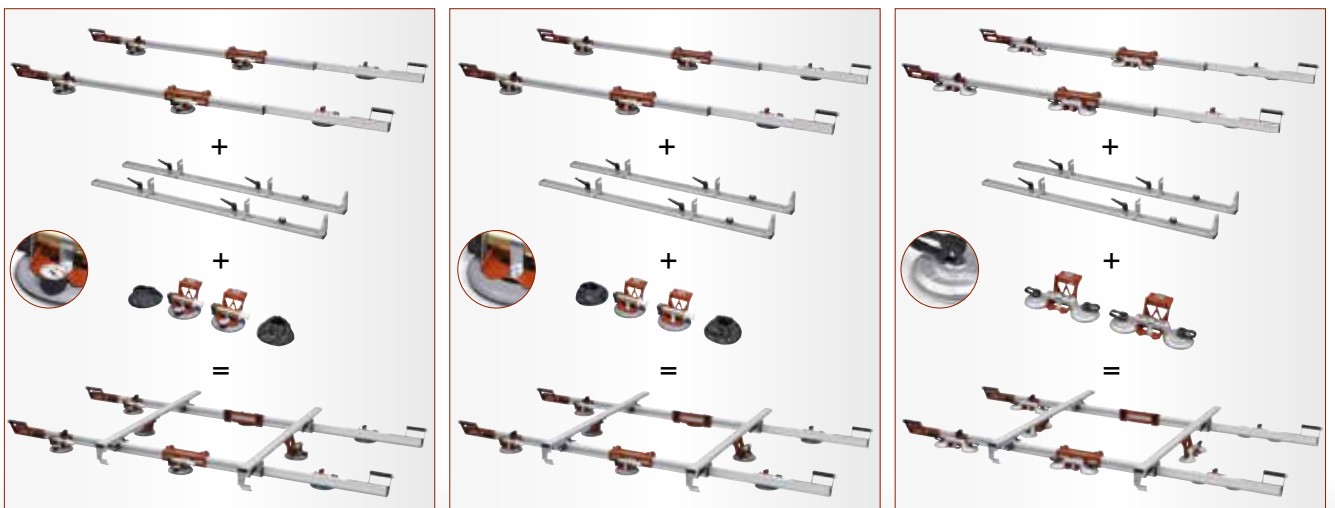

TOOLS FOR LARGE FORMAT TILES



169CML UN



CAM ADV - CART FOR TRASPORT AND STORAGE OF LARGE FORMAT TILES AND HANDLING DEVICES AND FOR SPREADING ADHESIVE ON THE BACK OF THE TILE ("BACK-BUTTERING")

- Cart designed for transport and handling of large format tiles (for instance 3200x1600x h 6 mm - 10.5'x5.25' x h 15/32").
- It allows to easily and safely spread adhesive in the back of the tile ("back-buttering"). For this purpose it comes with two height-adjustable hooks for holding our frames "EASY-MOVE ^{MMIII}" with crossbars" (and previous models) with the slab fasten on them.
- When the handling devices / frames (such as EASY-MOVE ^{MMIII}) are on the CAM ADV, the suction cups remain fully accessible. This allow to restore the vacuum (if needed) easily. This feature is particularly relevant when installing textured large format tiles..
- One side of the cart can be used as storage for the transport of one or more slabs.
- On the storage side there are 2 height-adjustable rubber supports, to prevent any accidental damage to the slabs as well as a telescopic safety hooks (which can be adapted to the dimension of the slab) to prevent slabs to fall.
- Wooden plans with rubber edges on both sides of the cart provide safe support for large format tiles.
- Two of the four pivoting wheels are provided with brakes so to prevent the cart to accidentally move.
- CAM ADV is light thanks to its design and the aluminum components.
- Maximum load: 250 Kg (551 lbs).

SPECIFICATIONS AND VERSIONS

Part No.			Description			
169CML UN	8024648094858	1	CAM ADV Cart for large format tiles and handling devices and for application of the adhesive in the back of the tile ("back-buttering")	30 Kg 66.1 lbs	140x43x h 30 cm 55 1/8"x17"xh 12"	34 Kg 60.6 lbs

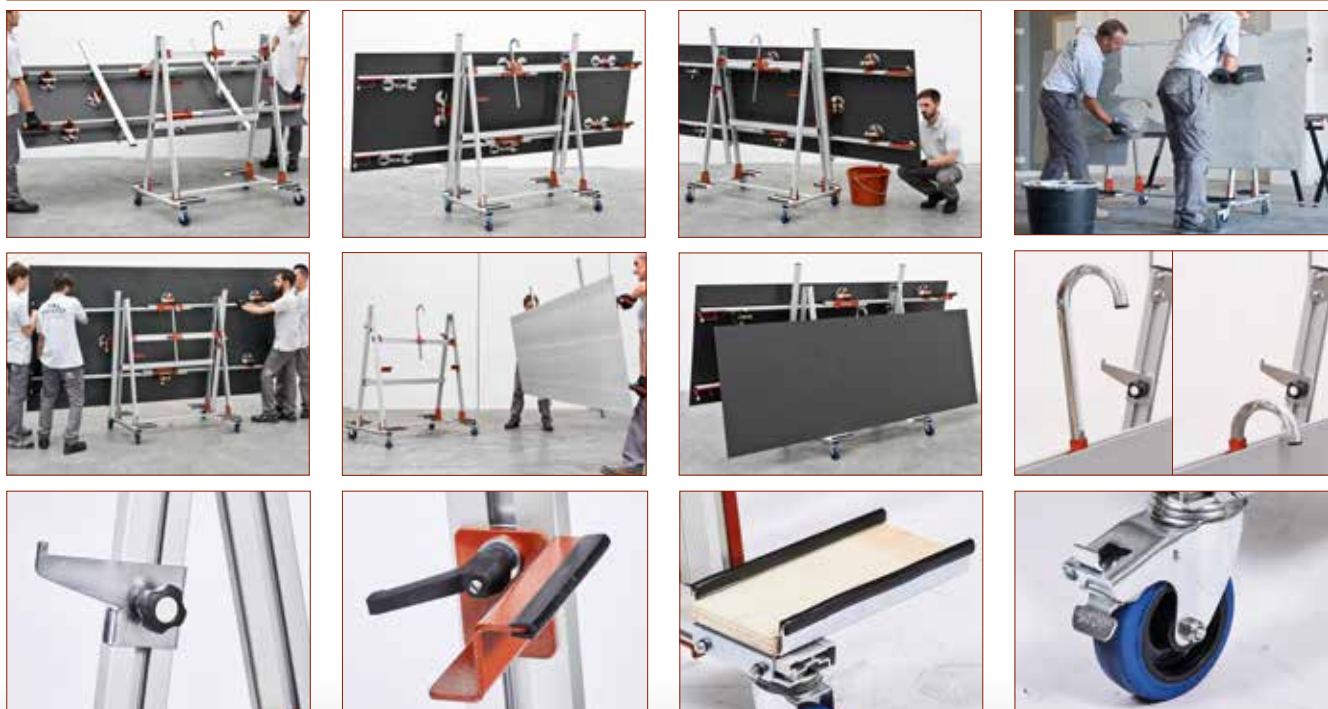

TOOLS FOR LARGE FORMAT TILES



321

TECHNICAL CHARACTERISTICS



41x21 cm

PACKAGE



CARTON BOX

- Designed to vibrate surface of large format tiles and help any air pocket escaping from underneath the slab, ensuring a full bound to the adhesive.
- Compact design, lightweight (6,7 Kg - 14.8 lbs) and easy to handle, it comes with 3 ergonomic handles which allow a comfortable and secure grip during both usages on floors and walls.
- The constant and uniformly applied vibration does not damage the slab even in the most risky situations (for instance, when large holes and/or cuts have been previously performed on the slab).
- High vibration frequency (motor Rpm: 3000 at 50 Hz; 3600 at 60 Hz).
- Vibration level can be adjusted via mechanical removal of eccentrics.
- Single speed.
- Stain-free-rubber plate designed to prevent stain and damage to the slab. Replaceable rectangular plate but with triangular point to easily reach the corners.
- Motor power: 25 Watt.

SPECIFICATIONS AND VERSIONS

Part No.	Barcode	Motor	Phase	Power	Speed	Dimensions	Frequency	Rotation
321 UE2	8050532000391	230 V 50/60 Hz	Single-phase	25 W	3000/3600	41x21 cm 16"x8 1/4"	-	-
321 US2	8050532000407	110 V 60 Hz			3600		-	-
321 GB2	8050532000414	110 V 50 Hz			3000		-	-

DIMENSION AND WEIGHT

Part No.	Weight	Dimensions	Volume	Weight
VOLPINO	1, 6,7 Kg 14.8 lbs	58x30xh 25cm	23"x12"xh 10"	7,2 Kg 15.9 lbs

SPARE PART

Part No.	Barcode	Quantity	Description	Weight
321LA03A	8024648014467	1	Stain-free rubber plate (spare part)	1,4 Kg 3.1 lbs



TOOLS FOR LARGE FORMAT TILES

MADE IN ITALY

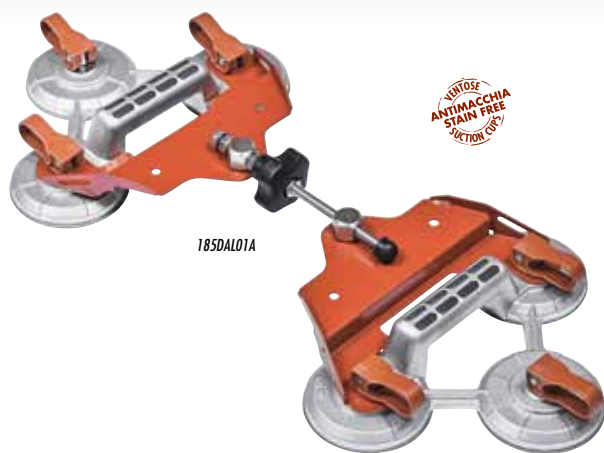

185DAL01A

VERGHE
ANTIMACCHIA
STAIN FREE
SUCTION CUP



142G

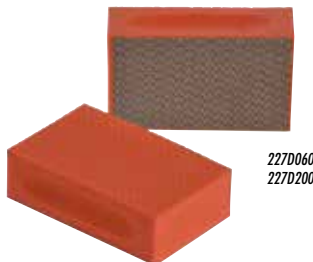

227D060
227D200

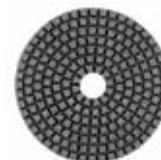

274FD100G0050

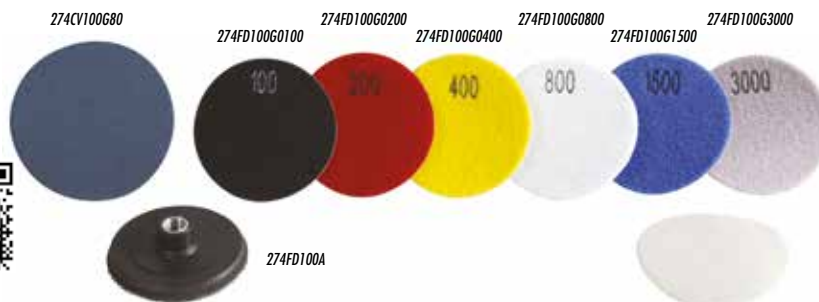

ACCESSORIES FOR CLOSER
FOAM WASHER

PACKAGE
CARTON BOX

CLOSER - DEVICE TO ACCOST TILES/SLABS WITH STAIN-FREE-RUBBER SUCTION CUPS

- To accost big tiles/slabs.

Part No.	Barcode	Box	Description	Weight	Dimensions
185DAL01A	8024648079862	2	"Closers" dispdevice to accost tiles/slabs with stain-free-rubber suction cup	4 Kg 8.8 lbs	58x20xh 25 cm 19 5/8"x8"x10"

RUBBER ANTI-BOUNCING TILE BEATER

- To improve adhesive bounding and to expel air from underneath the slabs/tiles.
- Rubber bottom to prevent tiles/slabs damages.
- Sturdy galvanized steel structure.
- The off-set handle increases effectiveness.

Part No.	Barcode	Box	Description	Weight	Dimensions
142G	8024648078582	6	Rubber tile beater	1,5 Kg 3.3 lbs	40x40xh 15 cm 5 3/4"x12 5/8"xh 4 3/4"

DIAMOND PADS

- To finish the edges of tiles / slabs after cutting.
- Available grains 60 and 200.

Part No.	Barcode	Box	Description	Weight	Dimensions
227D060	8024648077578	5	Diamond pad 55x90 mm grain 60	10 gr 0.35 oz	55x90 mm 2 1/8"x3 1/2"
227D200	8024648077585	5	Diamond pad 55x90 mm grain 200	55 gr 1.9 oz	

DIAMOND PADS FOR EDGE AND SIDE FINISHING / POLISHING

- Use on angle grinder RPM: min 1.800 / MAX 4.000

Part No.	Barcode	Box	Description	Material	Grain	Weight
274FDGP50	8050532006713	1	Kit of 7 diamond pads	for porcelain	Ø 100	80 gr 2.8 oz
274FD100G0050	8024648097293	5	Diamond pad grain 50	-	Ø 100	gr.50 50 gr 1.8 oz
274FD100G0100	8024648081933	5	Diamond pad grain 100	-	Ø 100	gr.100 50 gr 1.8 oz
274FD100G0200	8024648081940	5	Diamond pad grain 200	-	Ø 100	gr.200 50 gr 1.8 oz
274FD100G0400	8024648081957	5	Diamond pad grain 400	-	Ø 100	gr.400 50 gr 1.8 oz
274FD100G0800	8024648081964	5	Diamond pad grain 800	-	Ø 100	gr.800 50 gr 1.8 oz
274FD100G1500	8024648081971	5	Diamond pad grain 1500	-	Ø 100	gr.1500 50 gr 1.8 oz
274FD100G3000	8024648081988	5	Diamond pad grain 3000	-	Ø 100	gr.3000 50 gr 1.8 oz
274CV100G80	8024648015648	5	Zirconium abrasive disc with Velcro attachment grain 80	-	Ø 115	gr.80 50 gr 1.8 oz
274FD100A	8024648081506	1	Pad with velcro Ø 100 mm - 14MA attachment	-	Ø 100	- 60 gr 2.1 oz



TOOLS FOR LARGE FORMAT TILES

KOMPASS - DEVICE TO PERFORM CIRCULAR CUTS

MADE IN ITALY



ANTIMACCHIA STAIN FREE SECTION 100%

KOMPASS scribing

433KOMP 50

slicing via angle grinder

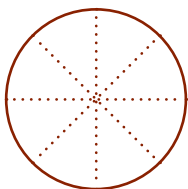

PACKAGE



CARTON BOX

• KOMPASS - DEVICE TO PERFORM CIRCULAT CUTS

- Device to perform large diameter circular cuts on large format tiles using the score and snap system.
- It is possible to perform centered, and off centered holes, in relation to the position of the suction cup which holds the KOMPASS to the slab.
- Centered holds dimension: min. Ø 22 cm (8 5/8"), max. Ø 100 cm (39 3/8").
- Off-centered hole dimension: min. Ø 32 cm (12 5/8"), max. Ø 100 cm (39 3/8").
- Diamond scoring wheel Ø 16 mm with pin and bearings.
- Metric/imperial ruler with pointer showing hole diameter.
- Light and easy to transport.
- To complete the processing of the hole is almost always necessary to perform slicing with an angle grinder and removing the cloves afterward.
- It is possible to perform a full circular hole, a semicircular hole, and 1/4 of circle, rounding the corner of the slab.

Part No.	Barcode	Description	CENTERED HOLES Ø DIMENSION	OFF-CENTERED HOLES Ø DIMENSION	Weight	Dimensions
433KOMP 50	8050532000742	1 KOMPASS - device to perform circular cuts	22 cm - 100 cm 8 5/8" - 39 3/8"	32 cm - 100 cm 12 5/8" - 39 3/8"	1,2 Kg 2.6 lbs	15x15xh 69 cm 6"x6"xh 27"



TOOLS FOR LARGE FORMAT TILES



171TG RAI

TIP-TOP. FACE-UP MITER-CLAMPING-DEVICE FOR STAIRS AND COUNTERTOPS OF ANY LENGTH

- Face-up miter clamping devices designed to work with fully visibility of the corner on tiles and stones of any length.
- It allows the user to see the corner with no need to bend.
- Independent double micrometric adjustments (vertical - up and down / horizontal - back and forward) allows to easily create the perfect corner.
- No tile length limits make it perfect for large format porcelain tiles as well.
- As a general guideline we recommend to use a pair (1 kit) on tiles or stones up to 200 cm (6.6') length. For longer tiles just add additional units. Slider adjustment to accommodate laminated edges from 30 to 300 mm (1 3/16" – 12")
- Steps/top dimensions (performances):
 maximum tile length: ∞ (infinite / no limit of length);
 riser: maximum 300 mm (12"); minimum 30 mm (1 3/16").
 maximum tile width: ∞ (infinite / no width limit);
- Suitable also for corner gluing (3 tiles). At least two kits (4 devices) are necessary to perform this particular operation.
- The 3 ballasts weighing a total of 1.2 kg (2.6 lbs) which equip each device contribute to create the perfect weights distribution to keep the tiles in position.
- The 2 stain-free rubber suction cups (Ø 88 mm; 3.5") which equip each device help keeping them in place while doing up & down /back & forward micro-adjustments.
- Black reference bands make it easy and fast to place the devices on the top of the tiles in the right position.
- TIP-TOP is designed to work on the top of the tiles. Tiles must be positioned on a stable, sturdy and big-enough table. We recommend to use one or more BM180^{PLUS} or BM180^{MAX} tables (worktop dimensions up-to 360x150 cm and even more if needed).
- Each TIP-TOP kit consists of two devices / units.
- TIP-TOP is extremely compact and light (6.2 kg / 13.6 lbs per pair / kit) for ease of storage and transport.

SPECIFICATIONS AND VERSIONS

Part No.			Description			
171TG RAI	8050532005686	1	TIP-TOP. Pair of face-up miter-clamping-devices for stairs and countertops of any length	6,2 Kg / 13,7 lbs	50x50xh 27 cm / 20"x20"xh 10 5/8"	9 Kg / 19,8 lbs

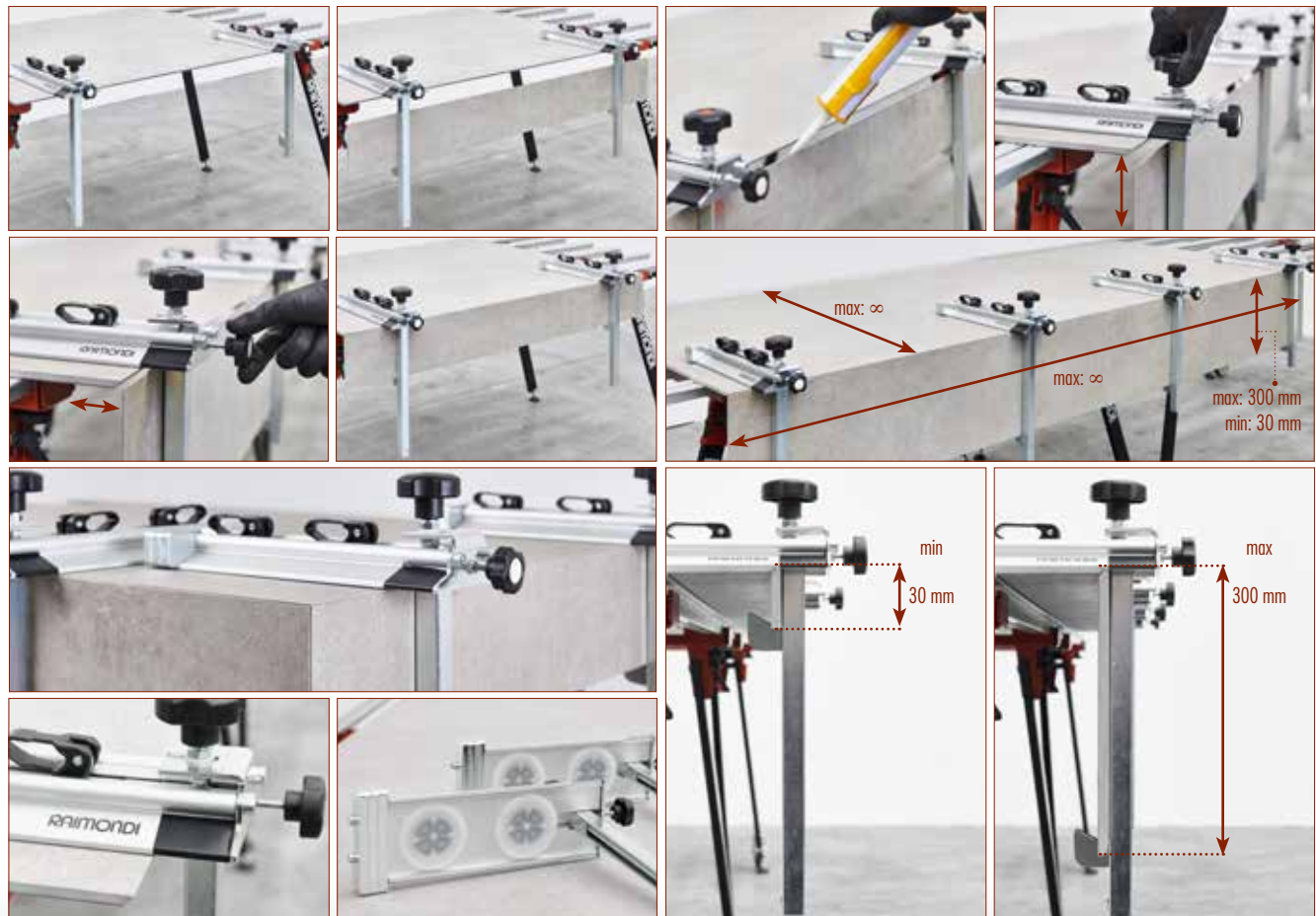

TOOLS FOR LARGE FORMAT TILES

90° GLUING KIT (FOR STEPS AND COUNTERTOP)

MADE IN ITALY

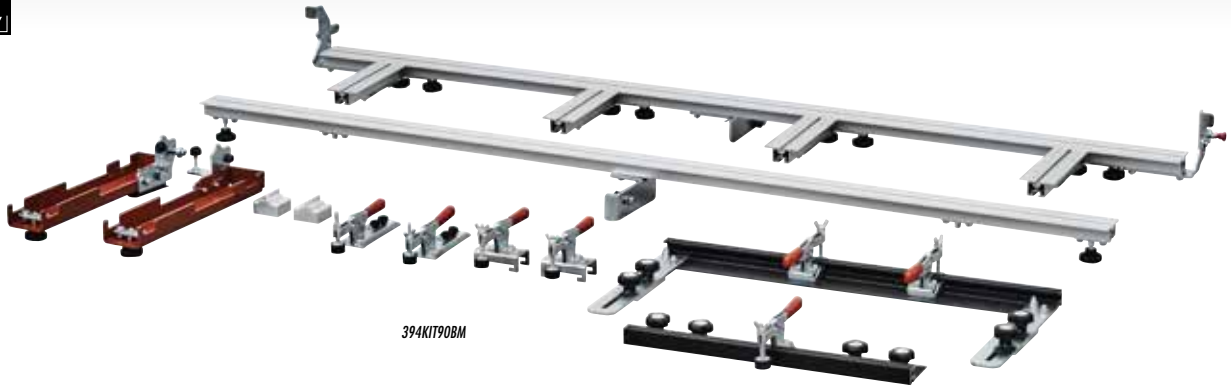

394KIT90BM



* The product does not include BM180^{Mod} modular bench

90° GLUING KIT (FOR STEPS AND COUNTERTOP)

- Miter joining fixture designed to be quickly installed on bench BM180^{Mod} (as well as on previous version) to bond steps, countertops and swimming pool copings.
- The product includes clamps and a pivot mechanism to joint tiles at 90° after miter cut has been performed on them.
- The product includes a pair of aluminum spacers to easily set the proper clearance between the tile pieces to be bonded together.
- The product has been designed to perform up to 2 joints on the same tile and so achieving a "U" shaped steps or counter top.
- Max achievable steps/counter top dimensions:
overall length: 150cm;

- overall height: 20cm;
- overall depth: ∞
- Bench BM180^{Mod} is not included.
- Each Bench BM180^{Mod} can be equipped with up to 2 Miter joining fixture (90° gluing kits).
- Tiles are held in place with removable clamps, easy to be positioned and adjusted.
- The product includes positioning squares for the tile pieces.
- Allows an easy positioning of the tile pieces, is quick to be operated, very sturdy.
- Can be adjusted at any time to keep its accuracy.

Part No.			Description						
394KIT90BM	8024648099273	1	90° gluing kit to create steps counter top	25 Kg	55.1 lbs	213x46xh 15 cm	84"x18"xh 6"	30 Kg	66.1 lbs

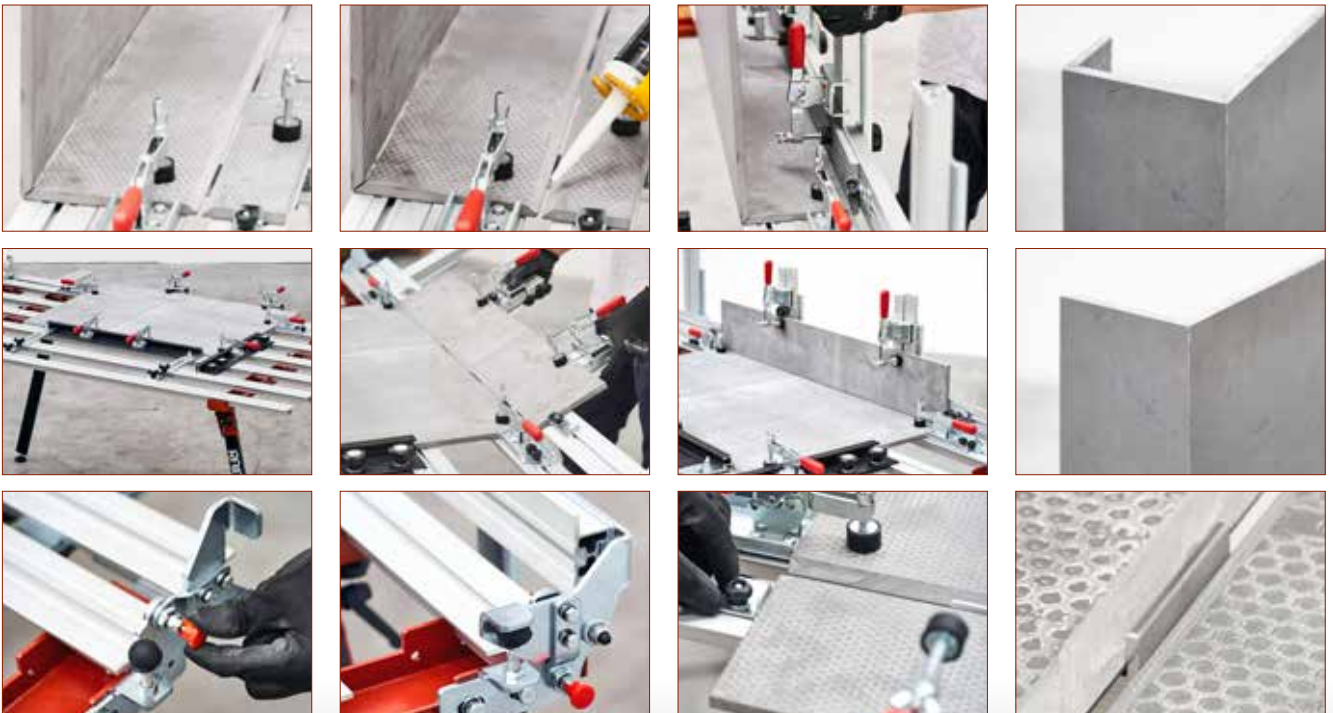

TOOLS FOR LARGE FORMAT TILES

MANUAL TILE CUTTERS



TILE CUTTERS

BI-DIRECTIONAL TILE CUTTERS	T2
PUSH TILE CUTTERS	T3



Professional, lightweight, accurate. Three adjectives to describe our line of manual tile cutters. Available with either bi-directional and push cut. For cutting tiles from 63 to 125 cm in length.

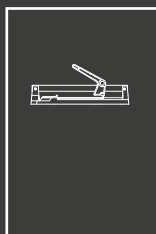

BI-DIRECTIONAL TILE CUTTERS

MADE IN ITALY

1 YEAR WARRANTY



254RAI75



254RAI63

PACKAGE



BOX

- Professional, light, accurate, strong.
- Ergonomic grip for bi-directional cut (pulling or pushing).
- No adjustment required for different tile thicknesses.
- Scratch-resistant pads on the breaking feet wont mar delicate glazes.
- Cast aluminum board makes this cutter light, while the steel rail and roller provide superior strength with low maintenance (no seals).
- The cutting wheel is mounted with a pin that can be easily tapped out for quick and effortless wheel replacement (one size fits all).
- Pivoting fence for cuts from 0° to 75° with pre-marked stops at the popular angles of: 15/30/45 degrees.
- A sliding stop that flips up out of the way to make additional cuts without losing your previous measurements (useful for carpet pattern layouts).
- The spring loaded table and foam extension pads provide alternate breaking methods and the proper amount of impact absorption to reduce broken tile (especially on the harder porcelains).
- On board storage compartment for up to (2) replacement cutting wheels.

SPECIFICATIONS AND VERSIONS

Part No.	Barcode	Box	Table	Roller	Spindle	Weight	Dimensions	Weight	Dimensions	Weight	Dimensions	
254RAI75	8024648005083	1	75 cm	29 1/2"	∞	53x53 cm	20 7/8"x20 7/8"	9,4 Kg	20.7 lbs	106x40xh 25 cm	11 Kg	24.2 lbs
254RAI63	8024648005090	1	63 cm	24 13/16"	∞	44x44 cm	17 5/16"x17 5/16"	8,4 Kg	18.5 lbs	41 3/4"x15 3/4"xh 10"	10 Kg	22 lbs

CUTTING WHEELS

Part No.	Barcode	Box	Description	Weight	Dimensions	Weight	Dimensions
13514	8024648005137	12	Ø 14 mm wolfram carbide wheel with spindle	7 gr	0.2 oz	24x17xh 1 cm	10"x6 3/4"xh 3/8"
13514TITTA	8024648005144	12	Ø 14 mm TITANIUM wheel with spindle				



MANUAL TILE CUTTERS

RAIMONDI

MADE IN ITALY

1 YEAR WARRANTY



254RAI125S

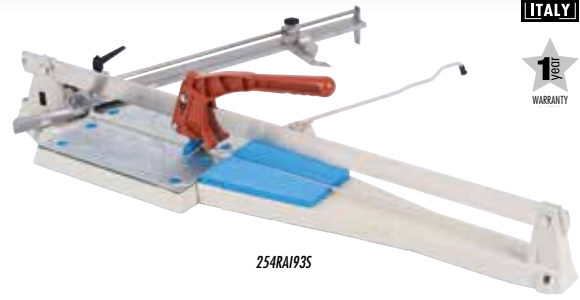

254RAI93S



254RAI63S

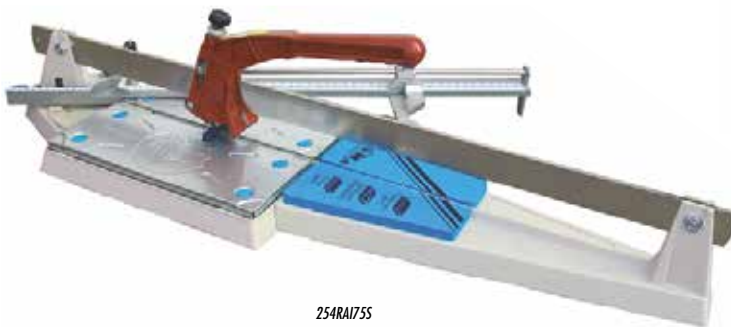

254RAI75S

PACKAGE



BOX

- Professionali, leggere, precise.
- Impugnatura ergonomica per una incisione a spinta.
- Non richiede alcuna regolazione in funzione dello spessore della piastrella.
- Squadra orientabile per tagli da 0° a 75° con doppia squadra millimetrata.
- Dispositivo antigraffio per smalti delicati.
- Piani d'appoggio piastrella in acciaio con prolunga in gomma A.D.

SPECIFICATIONS AND VERSIONS

Part No.	Barcode	Box	Table	Table	Table	Table	Weight	Weight	Table	Table	Weight	Weight	
254RAI125S	8024648097187	1	125 cm	49 1/4"	∞	88x88 cm	34 2/3" x 34 2/3"	20 Kg	44.1 lbs	166x44x h 26 cm	65 2/5" x 17 5/16" x h 10"	21 Kg	46.3 lbs
254RAI93S	8024648097194	1	93 cm	36 1/3"	∞	66x66 cm	26" x 26"	10,5 Kg	23.1 lbs	124x40xh 23 cm	49" x 15 3/4" x h 9"	23,1 Kg	50.9 lbs
254RAI75S	8024648014542	1	75 cm	29 1/2"	∞	53x53 cm	20 7/8" x 20 7/8"	9,4 Kg	20.7 lbs	106x40xh 25 cm	41 3/4" x 15 3/4" x h 10"	11 Kg	24.2 lbs
254RAI63S	8024648014559	1	63 cm	24 13/16"	∞	44x44 cm	17 5/16" x 17 5/16"	8,4 Kg	18.5 lbs	106x40xh 25 cm	41 3/4" x 15 3/4" x h 10"	10 Kg	22 lbs

CUTTING WHEELS

Part No.	Barcode	Box	Description	Weight	Weight	Table	Table	Weight	Weight
13514	8024648005137	12	Ø 14 mm wolfram carbide wheel with spindle	7 gr	0.2 oz	24x17xh 1 cm	10" x 6 3/4" x h 3/8"	100 gr	3.5 oz
13514TITA	8024648005144	12	Ø 14 mm TITANIUM wheel with spindle						

