

# Planiseal VS Fast

Fast-Track, Alkali-Resistant, Epoxy Moisture-Reduction Barrier



## DESCRIPTION

*Planiseal*<sup>®</sup> VS Fast is a fast-curing, alkali-resistant, two-component, 100%-solids, epoxy coating that effectively stops moisture-related problems over concrete that impact floor coverings. In addition, it significantly expedites floor installations by eliminating the traditional wait time required for new concrete slabs to reach moisture levels suitable for floor-covering installation.

## FEATURES AND BENEFITS

- Compliant with ASTM F3010
- Can be installed directly over clean concrete without mechanical profiling
- Dries in about 4 to 6 hours after application

## INDUSTRY STANDARDS AND APPROVALS

- ASTM: Meets or exceeds the performance attributes of ASTM F3010-13 (Standard Practice for Two-Component Resin-Based Membrane-Forming Moisture Mitigation Systems for Use Under Resilient Floor Coverings)

## WHERE TO USE

- Sound and stable interior concrete substrates that are at least 5 days old

## LIMITATIONS

- Do not install over substrates containing asbestos.
- Do not install unless the substrate and ambient temperatures are between 50°F and 85°F (10°C and 29°C).
- Do not install repair mortars, screeds, self-leveling underlayments or patching compounds beneath *Planiseal VS Fast* unless they are rated for exterior use.
- Do not apply on wet substrates.
- Do not use on on-grade slabs that are subject to freeze/thaw cycles.
- Do not install over gypsum-based underlayments.
- Do not install over wood underlayments.
- Do not install unless the temperature of the prepared concrete slab is at least 5 degrees Fahrenheit (2.8 degrees Celsius) above the dew point, in order to avoid condensation.
- Do not use as a final wear surface. *Planiseal VS Fast* must be covered with a flooring system. Expansion, movement and isolation joints must be honored through the finished flooring system.
- Acid etching is not a suitable means to prepare concrete subfloors to receive epoxy membranes.

Note: During installations on green concrete, continued shrinkage in the substrate during cure may lead to the formation of cracks that will break the *Planiseal VS Fast* membrane and breach the moisture barrier. Cracks generated by substrate movement are not covered by the MAPEI warranty.

## SUITABLE SUBSTRATES

- Concrete substrates that are 5 days old, with a minimum tensile strength of 150 psi (1.03 MPa) when tested per ASTM D7234. They must either be in pristine condition or have been mechanically prepared using dustless engineer-approved methods to an International Concrete Repair Institute (ICRI) concrete surface profile (CSP) of #2 to #3.

Consult MAPEI's Technical Services Department for installation recommendations regarding substrates and conditions not listed.

## SURFACE PREPARATION

- For direct application without mechanical profiling, concrete must be porous, have a surface CSP of #2 to #3, and be in pristine condition with no contamination present.
- If conditions in the preceding paragraph are not present, the surface must be mechanically profiled using dustless, engineer-approved methods to obtain a CSP of #2 to #3. Ensure that all old adhesives, contaminants, curing compounds, oils, silicates, dust and other bond breakers are completely removed. Inadequate surface preparation may lead to pinholing, bubbling, bond loss and subsequent failure of the moisture barrier.

Note: Some substrates may require waiting 16 to 24 hours after mechanical profiling to reduce outgassing from the surface and subsequent pinholes in the membrane.

- *Planiseal VS Fast* is designed for moisture mitigation only. Consult with an experienced engineer to determine the appropriate substrate repair procedures and joint treatment methods. The crack repair procedures and joint treatment methods listed below should be considered by a consultant or engineer to address contraction as well as potential expansion, movement and isolation joints. Regardless of treatment, MAPEI does not warrant against the appearance of cracks or debonding that results from subsequent substrate movement of any kind.
- Mechanically prepare control and construction/expansion joints with a diamond crack-chasing/concrete-cutting blade. Overcut the joint width to obtain a sound, clean edge. Clean cracks or joints with oil-free compressed air and/or vacuum with a dustless collection system to completely remove contaminants (follow ACI RAP Bulletin 2, "Crack Repair by Gravity Feed with Resin").

### Crack repair

Repair any open cracks after the applied *Planiseal VS Fast* has dried. Cracks narrower than 1/8" (3 mm) may typically be filled with *Planiseal VS Fast* neat. Cracks wider than 1/8" (3 mm) should be repaired by filling with a suitable high-modulus epoxy; consider adding sand to create an epoxy mortar, if appropriate.

### Contraction, control or saw-cut joint treatment

Dormant control joints may typically be filled with *Planiseal VS Fast*, or with an alternate high-modulus epoxy (consider an epoxy mortar if appropriate) after the installation of *Planiseal VS Fast*. Fill the joints to be full-depth and flush to the surface.

### Expansion, movement and isolation joint treatment

See the following diagram.

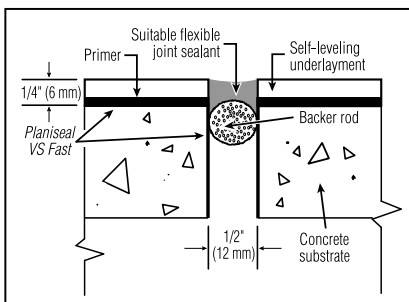

## MIXING

Before product use, take appropriate safety precautions. Refer to the Safety Data Sheet for details.

1. Premix Part A to a homogenous consistency (for 2 to 3 minutes) using a low-speed mixer and a Jiffy (paint mixer) mixing paddle.
2. Pour Part B into the Part A container and mix thoroughly to a smooth, homogenous consistency. Do not mix at high speeds, which can trap air within the mixed material.
3. Pour the entire mixed unit onto the substrate within 5 minutes of mixing.

Note: Mixed *Planiseal VS Fast* will generate dangerous amounts of heat when cured in mass. Do not leave mixed *Planiseal VS Fast* in the mixing container longer than 5 minutes, in order to avoid premature curing and excessive heat generation.

## PRODUCT APPLICATION

Read all installation instructions thoroughly before installation.

1. Apply *Planiseal VS Fast* to the substrate and immediately pull it tight to the surface with a flat squeegee.
2. Within 30 to 45 minutes of the first pass, reapply the mixed *Planiseal VS Fast* using a squeegee measuring 3/16" to 1/4" (4.5 to 6 mm). If required, also back-roll the installation with a caged roller that has a short nap (1/4" to 3/8" [6 to 10 mm]), achieving the required dry film thickness (DFT) on the surface as indicated in the "Required Application Thickness and Associated Coverage" chart below.
3. Ensure that all voids and pinholes are filled/sealed before moving on to the next flooring phase. Do so by filling any voids and/or shaving off the tops of any bubbles and reapplying a thin coating of *Planiseal VS Fast* over the surface.

## CLEANUP

Use soap with water or use denatured alcohol to clean equipment before *Planiseal VS Fast* cures to a hardened state. Cured material can only be removed mechanically.

## PROTECTION

Protect the surface of the cured *Planiseal VS Fast* from traffic or damage until covered by a subsequent product.

### Product Performance Properties

Laboratory Tests	Results
Permeability	< 0.1 perm at ≥ 10 mils DFT per ASTM E96-05
Reduction of moisture vapor	> 96% per ASTM E96-05 (10 mils DFT)
Pull-off adhesion / bond strength	> 1,000 psi (6.90 MPa) with failure in concrete substrate (at 28 days per ASTM D7234)
Resistance to high alkalinity (pH 14)*	14-day spot test, covered – no effect 14-day spot test, uncovered – no effect 14-day immersion – no effect
VOC content (SCAQMD Rule 1113)	< 50 g per L
Typical VOC content per SCAQMD Rule 1113 testing methods	3 g per L

\* Tested per ASTM D1308 with both a 10% and 30% solution of sodium hydroxide, at a pH of 14

### Shelf Life and Product Characteristics

before mixing

Shelf life	2 years when stored in original, unopened packaging in a dry place at 40°F to 95°F (4°C to 35°C)
------------	--

<b>Composition</b>	2-part, 100%-solids epoxy
<b>Color</b> Part A Part B	Transparent yellow Transparent amber

Protect containers from freezing in transit and storage. Provide for heated storage on site and deliver all materials at least 24 hours before work begins.

### Application Properties

<b>Consistency</b>	Pourable liquid
<b>Pot life</b>	5 to 10 minutes
<b>Drying time at 73°F (23°C) until tack-free (the time required before permitting walking on the surface or subsequent installations)</b>	4 to 6 hours
<b>Flash point (Seta flash)</b>	> 199°F (93°C)

### Required Application Thickness and Associated Coverage

<b>Treating areas with a moisture vapor emission rating (MVER) of up to 25 lbs. (11.3 kg) per ASTM F1869, and relative humidity of up to 100% per ASTM F2170</b>	> 10 mils of DFT (~14 mils WFT) = 100 to 150 sq. ft. per U.S. gal. (2.45 to 3.67 m <sup>2</sup> per L)*
--	---

\* This is the typical number realized in field conditions. Coverage depends on the desired build as well as the profile and porosity of the substrate.

### CSI Division Classification

<b>Dampproofing and Waterproofing</b>	07 10 00
---------------------------------------	----------

### Packaging

Part A, Pail: 2.1 U.S. gals. (7.95 L)
Part B, Jug: 0.9 U.S. gal. (3.41 L)

## RELATED DOCUMENTS

Reference Guide: Surface Preparation Requirements for floor-covering installation systems\*\*

\*\* At [www.mapei.com](http://www.mapei.com)

## ADDITIONAL INFORMATION

Refer to the Safety Data Sheet (SDS) for specific data related to health and safety as well as product handling.

For information on MAPEI's commitment to sustainability and transparency, as well as how MAPEI products may contribute to green building standards and certification systems, contact [sustainability\\_USA@mapei.com](mailto:sustainability_USA@mapei.com) (USA) or [sustainability-durabilite@mapei.com](mailto:sustainability-durabilite@mapei.com) (Canada).

## WARNING

The test results shown in the TECHNICAL DATA table were obtained in compliance with test methods and curing cycles, if applicable, defined in the industry standards referenced on the Technical Data Sheet. Please note that the use of test procedures or methods other than those indicated in the table could lead to different values and that, in such cases, any liability of our company is excluded.

### LEGAL NOTICE

The contents of this Technical Data Sheet ("TDS") may be copied into another project-related document, but the resulting document shall not supplement nor replace requirements per the TDS in effect at the time of the MAPEI product installation. For the most up-to-date TDS and warranty information, please visit our website at [www.mapei.com](http://www.mapei.com). **ANY ALTERATIONS TO THE WORDING OR REQUIREMENTS CONTAINED IN OR DERIVED FROM THIS TDS SHALL VOID ALL RELATED MAPEI WARRANTIES.**

Before using, the user must determine the suitability of our products for the intended use, and the user alone assumes all risks and liability. **ANY CLAIM SHALL BE DEEMED WAIVED UNLESS MADE IN WRITING TO US WITHIN FIFTEEN (15) DAYS FROM DATE IT WAS, OR REASONABLY SHOULD HAVE BEEN, DISCOVERED.**

## CONTACT INFORMATION

### MAPEI Headquarters of North America

1144 East Newport Center Drive  
Deerfield Beach, Florida 33442  
1-888-US-MAPEI (1-888-876-2734) / (954) 246-8888

### Technical Services

U.S. and Puerto Rico:  
Flooring: 1-800-992-6273  
Concrete and heavy construction: 1-888-365-0614  
Canada:  
1-800-361-9309

### Customer Service

1-800-42-MAPEI (1-800-426-2734)

**Edition Date: September 8, 2025 MK 3007685 (25-2589)**

For the most current product data and BEST-BACKED<sup>SM</sup> warranty information, visit [www.mapei.com](http://www.mapei.com).  
All Rights Reserved. © 2025 MAPEI Corporation.

